

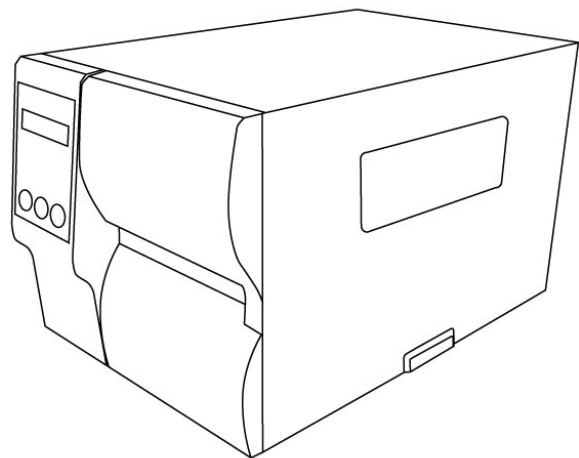

iX4 Pro Series Printer

User Manual



<https://www.argo.com>



[Installation Video]

Version: 1.1

Liability Disclaimer

Argox Corporation ensures that the company's published engineering specifications and manuals are correct; however, errors occur. Argox reserves the right to correct the mistakes and disclaim any resulting liability. In no event shall Argox or anyone else involved in the creation, production, or delivery of the accompanying product (including hardware and software) be liable for any damages whatsoever (including, without limitation, damages for loss of business profits, business interruption, loss of business information, or other pecuniary loss) arising out of the use of or the results of use of or inability to use such product, even if Argox has been advised of the possibility of such damages.

FCC Compliance Statement

This equipment has been tested and found to comply with the limits for a Class A digital device under Part 15 of the FCC Rules. These limits are designed to protect reasonably against harmful interference in a residential installation. This equipment generates, uses, and can radiate radio frequency energy and, if not installed and used by the instructions, may cause harmful interference to radio communications. However, there is no guarantee that the interference will not occur in a particular installation. Suppose this equipment does cause harmful interference to radio or television reception, which can be determined by turning the equipment off and on. In that case, the user is encouraged to try to correct the interference by the following measures:

Reorient or relocate the receiving antenna.

Increase the separation between the equipment and the receiver.

Connect the equipment to a different outlet on a different circuit.

Consult the dealer or an experienced Radio/TV technician for help.

This unit was tested with shielded cables on the peripheral devices. Shielded cables must be used with the unit to ensure compliance. The user is cautioned that any changes or modifications not expressly approved by Argox Information Co., Ltd. could void the user's authority to operate the equipment.

This is a Grade A product. In the living environment, the product may cause interference in radio communications. In this case, the user is encouraged to try to correct the interference using effective measures.



Caution

Ensure to connect the power cord of the power adapter to a socket outlet with an earth connection.

CAUTION: Explosion is risky if an Incorrect Type replaces the Battery. Dispose of Used Batteries According to the Instructions.

ATTENTION: Risque d'explosion si la batterie est remplacée par un type incorrect. Mettre au rebus les batteries usagées selon les instructions.

Caution

Any changes or modifications not expressly approved by the party responsible for compliance could void the user's authority to operate the equipment.

Contents

1	Introduction	1
1.1	Features	1
1.2	Unpacking.....	2
1.3	Understand your printer	3
1.3.1	Perspective view	3
1.3.2	Back view	4
1.3.3	Interior view	6
1.4	Printer control panel.....	7
1.4.1	Status lights.....	7
1.4.2	Buttons	9
2	Get started	10
2.1	Attach the power cord	10
2.2	Turn on/off your printer.....	11
2.2.1	Turn on your printer.....	11
2.2.2	Turn off your printer	12
2.3	Load media	13
2.3.1	Prepare media	14
2.3.2	Placing media roll.....	15
2.3.3	Media types	26
2.4	Load Ribbon.....	28
2.4.1	Placing Ribbon Roll	29
3	Printer operation	32
3.1	Front Panel	32
3.1.1	LCD Function Setting Procedure.....	33
3.2	Printing Media Calibration & Configuration	40
3.3	Printing a Configuration Report	41
3.4	Resetting to Factory Default Settings.....	51
3.5	Media sensing.....	52
3.5.1	Transmissive sensor	52
3.5.2	Reflective sensor.....	53
3.5.3	Adjust Position of Label Sensor	54
3.6	Communications.....	55
3.6.1	Interfaces and Requirements	55
3.7	Driver installation	57
3.7.1	Installing a Plug and Play printer driver (for USB only).....	58
3.7.2	Installing a Printer Driver (for other interfaces except USB)....	64

4	Configuration on Web Setting Tool	70
4.1	Attaching the power cord	70
4.2	Connecting the printer to a LAN hub	70
4.3	Getting the IP address of the printer	71
4.4	Logging in to the web setting tool	71
5	Maintenance	73
5.1	Cleaning.....	74
5.1.1	Printhead	74
5.1.2	Platen Roller.....	75
5.2	Printer Adjustments.....	76
5.2.1	Printer Head Pressure Adjustment	76
5.2.2	Ribbon Tension Adjustment.....	78
5.2.3	Printing Wrinkle Adjustment.....	80
5.2.4	Small-size Media Offset Adjustment.....	82
5.3	RTC Battery Replacement	83
7	Troubleshooting	84
7.1	Printer issues	84
7.2	Media issues	85
7.3	Ribbon issues.....	86
7.4	Other issues.....	87
8	Specifications	88
8.1	Printer.....	88
8.2	Media & Ribbon.....	90
8.3	Electrical and operating environment.....	91
8.4	Physical dimension	91
8.5	Fonts, Barcodes, and Graphics Specification.....	92
8.6	Wireless LAN (Option)	95
8.7	Interfaces.....	97
8.7.1	USB	97
8.7.2	RS-232C.....	98
8.7.3	GPIO.....	99
8.7.4	Ethernet.....	100

1 Introduction



Thank you for purchasing an Argox iX4 Pro Series industrial barcode printer. This manual provides information about setting up and operating your printer, loading media and ribbon, and solving everyday problems. Illustrations are provided to help you quickly become familiar with the printer.

1.1 Features

- **Fast Print Speed**
Max. 8 IPS, fastest print speed in its class
- **Communication**
Standard: Ethernet, dual USB hosts, USB device, and RS-232
Option: Wi-Fi and GPIO
- **Online management**
Web management and SNMP v2 support
- **Dual USB host function**
Stand-alone mode of scanner/keyboard multiple data entry devices
- **New media calibration**
Intelli mode & Smart mode

1.2 Unpacking

Make sure all of the following items are included in your package.

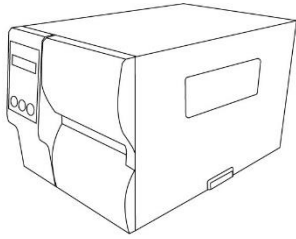

Printer

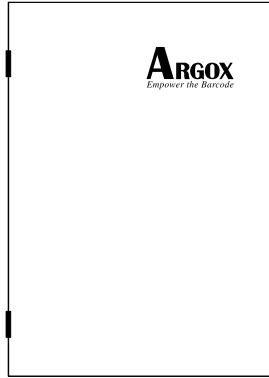

Quick Installation
Guide

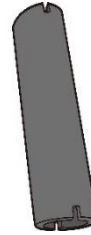

1" ID Core for Ribbon

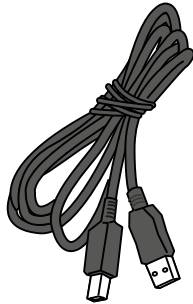

USB Cable

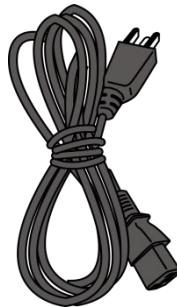

AC Power Cord

When you receive the printer, open the package immediately and inspect for shipping damage. Contact the shipping company and file a claim if you discover any damage. Argox is not responsible for any damage incurred during shipping. Save all package materials for the shipping company to inspect.



Note: If any item is missing, please get in touch with your local dealer.

1.3 Understand your printer

1.3.1 Perspective view

iX4-250 Pro, iX4-350 Pro

Top Access Door

LCD Display

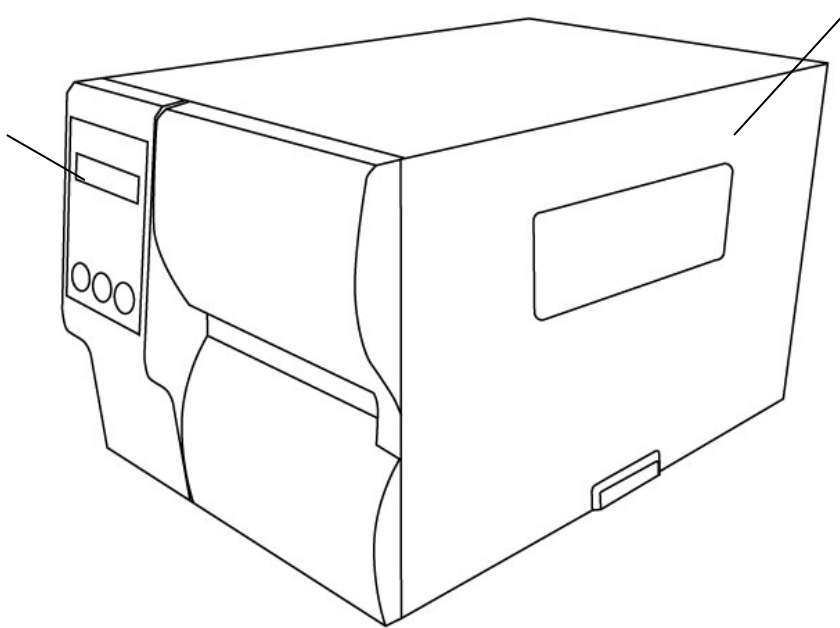

iX4-240 Pro, iX4-200 Pro

Top Access Door

Control panel

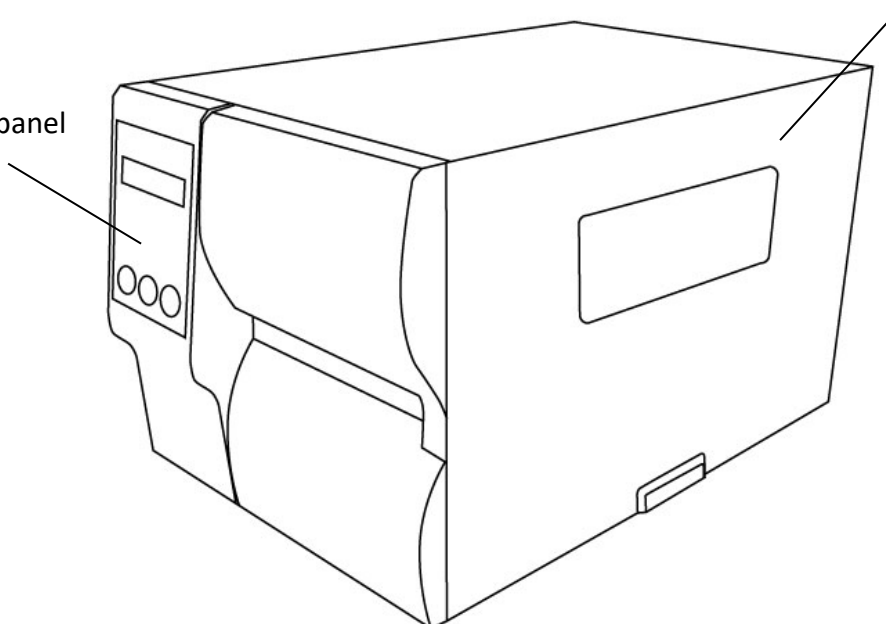

1.3.2 Back view

iX4-240 Pro, iX4-250 Pro, iX4-350 Pro Standard

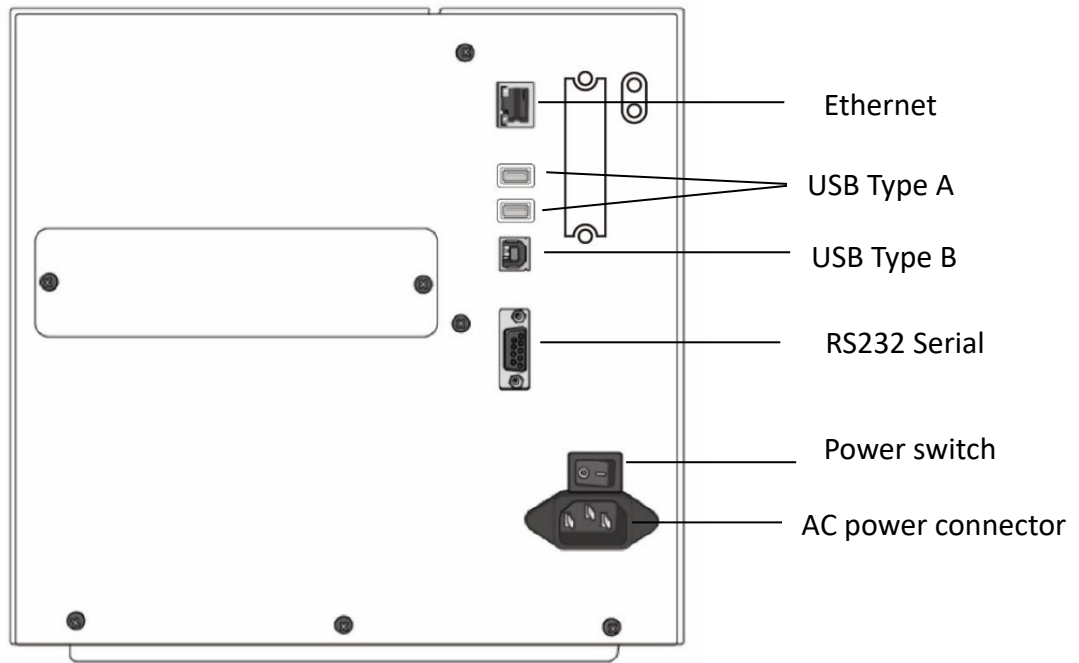

iX4-240 Pro, iX4-250 Pro, iX4-350 Pro Optional

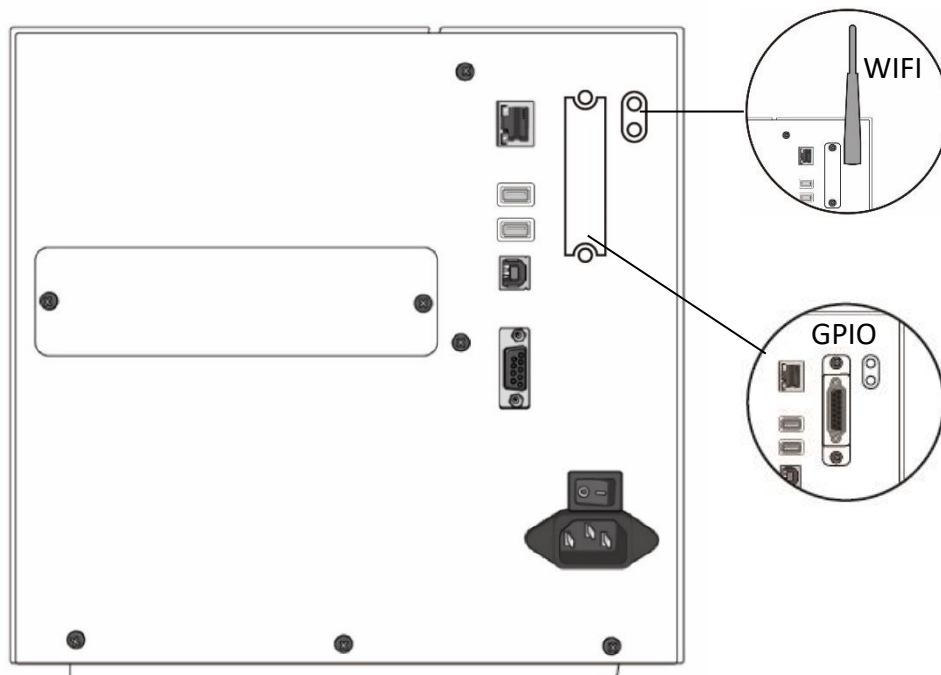

iX4-200 Pro Standard

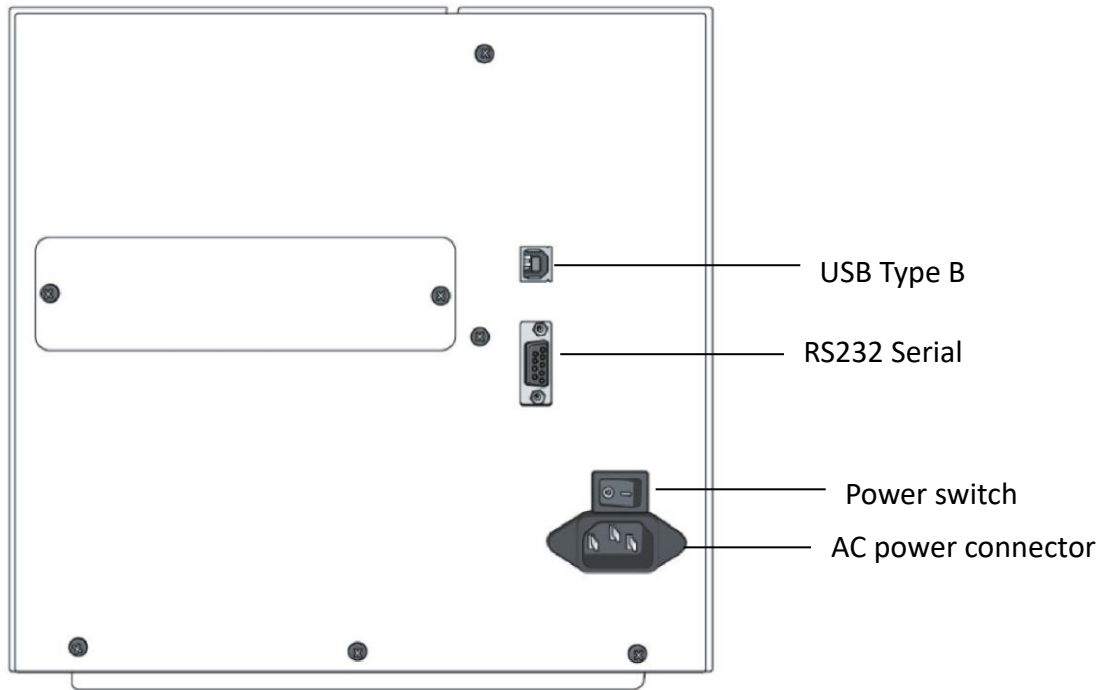

1.3.3 Interior view

Internal Parts and Features

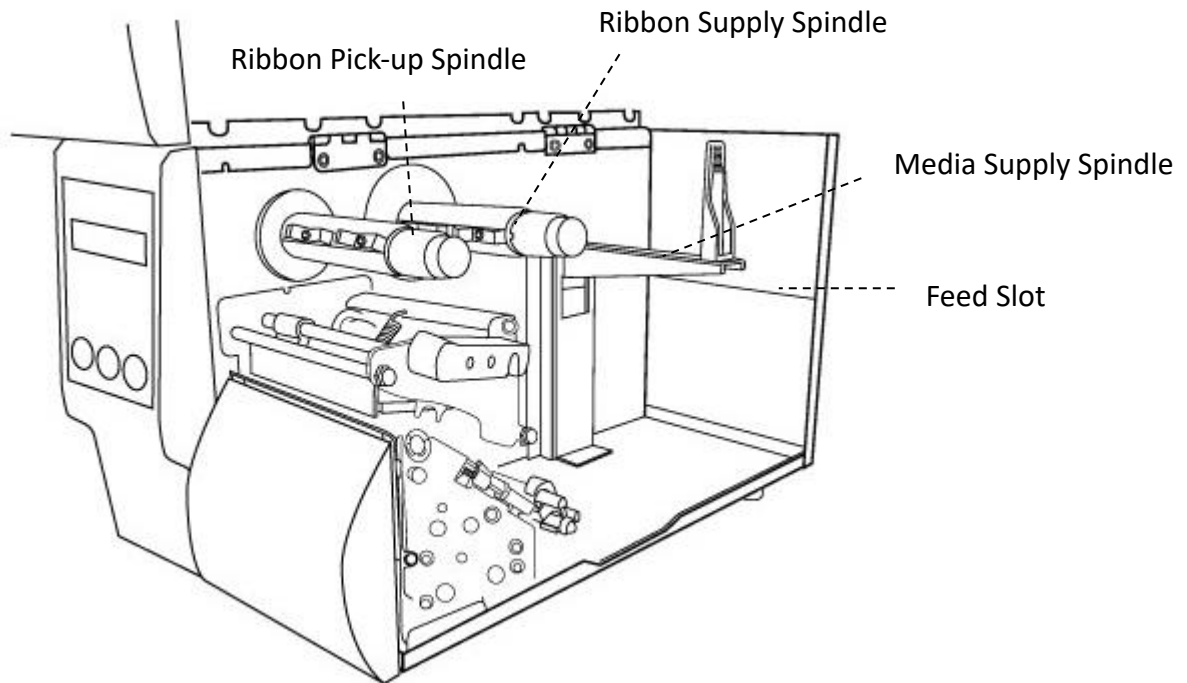

Rotate Head Latch

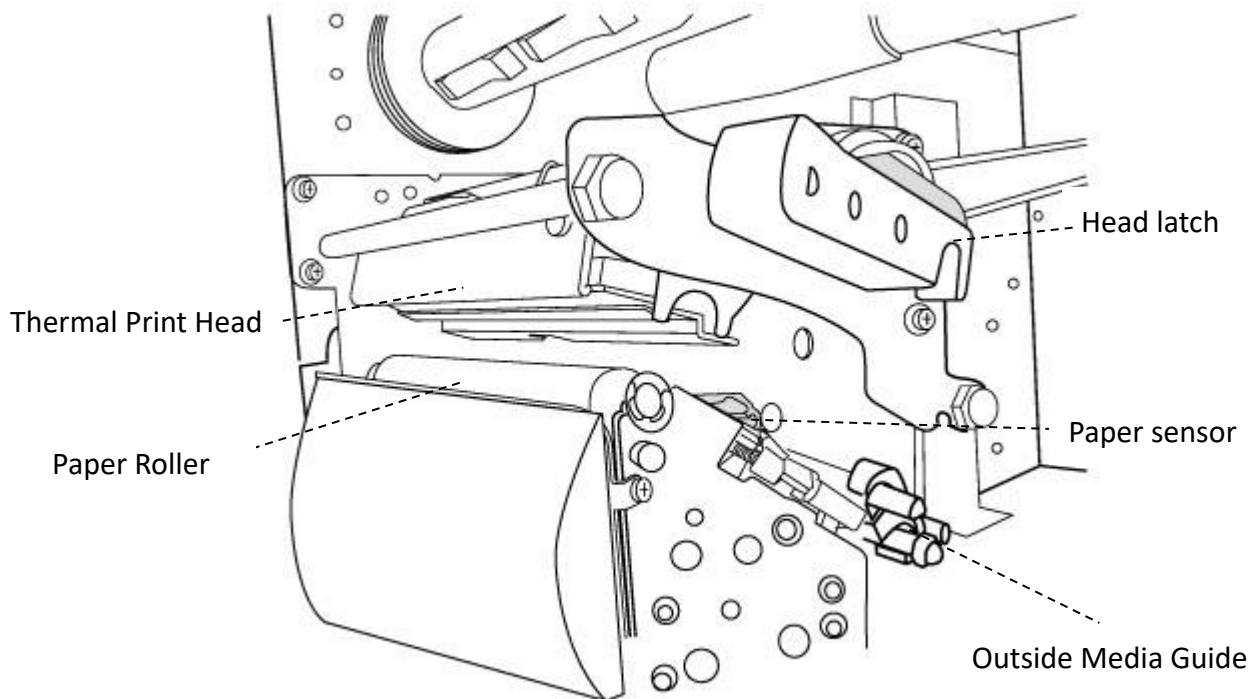

1.4 Printer control panel

There are three lights on the front panel - READY, MEDIA, and RIBBON. These indicators display the operation status of the printer. Three Buttons – FEED, PAUSE, and CANCEL can control the printer's simple functions.

1.4.1 Status lights

Status lights help you check the printer's condition. The following tables show the status lights and the conditions they indicate.

LCD Display	READY	MEDIA	RIBBON	Description
READY	ON	ON	ON	In the ready mode
PRINT HEAD HEAT	ON	Blinking	ON	The print head needs to cool down.
COMMAND ERROR	ON	Blinking	Blinking	A command error was found while checking the command sequence.
EEPROM ERROR	ON	Blinking	Blinking	An EEPROM for backup cannot be read/written properly.
MEMORY ERROR	ON	Blinking	Blinking	<ul style="list-style-type: none">• An error occurred when writing data into USB or flash memory.• An erase error has occurred in formatting USB memory or flash memory.• Saving failed because of USB or flash memory's insufficient capacity.• Firmware update has an error.
CANCEL ...	Blinking	ON	ON	Press CANCEL KEY to interrupt and delete a print task

LCD Display	READY	MEDIA	RIBBON	Description
CLEAR FLASH	Blinking	ON	ON	Clear flash memory.
CUTTER FAILED	Blinking	ON	ON	The cutter has failed, or there is a paper jam inside the cutter.
MEMORY FULL	Blinking	ON	ON	The loaded soft fonts, graphics, or forms entirely cause the printer buffer.
MEMORY INITIALIZED	Blinking	ON	ON	USB Memory is being initialized.
PAUSE	Blinking	ON	ON	The printer is in PAUSE status. Media sensor cannot index label gaps.
PRINthead BROKEN	Blinking	ON	ON	Head broken error
PRINT HEAD OPEN	Blinking	ON	ON	The head latch is not closed.
RESET	Blinking	ON	ON	Press CANCEL KEY + POWER ON to reset the NVR table.
SERIAL IO ERROR	Blinking	ON	ON	The format or baud rate of the RS232 communication is inconsistent between the printer and host.
SELF TEST ...	Blinking	ON	ON	Press FEED KEY + POWER ON to print the self-test label.
UPGRADING FW.	Blinking	ON	ON	The printer is receiving data
RIBBON OUT	Blinking	ON	Blinking	The ribbon was not installed, and the end-of-ribbon occurred.
CALIBRATION . ..	Blinking	Blinking	ON	Press the PAUSE KEY + POWER ON to calibrate the media.

LCD Display	READY	MEDIA	RIBBON	Description
MEDIA OUT	Blinking	Blinking	ON	Media is not installed or used up. The printer fails to detect the media gap. The media sensor is out of range during calibration. The label has run out. The last label has been issued typically and has run out.
PAPER JAM	Blinking	Blinking	ON	A paper jam occurred during a paper feed.

1.4.2 Buttons

There are three buttons, each with two essential functions.

Button	Function 1	Function 2
FEED	<ul style="list-style-type: none"> Feed a label 	
PAUSE	<ul style="list-style-type: none"> Pause printing 	<ul style="list-style-type: none"> Press again to resume printing
CANCEL	<ul style="list-style-type: none"> Interrupt and delete a print task 	<ul style="list-style-type: none"> Force the printer to continue after an error is solved.

2 Get started

This chapter describes how to set up your printer.

2.1 Attach the power cord

1. Make sure the power switch is set to the **OFF** position.
2. Place the printer within cable distance of the host and printer (USB or Serial cable.)
3. Isolate the power cord from other electrical cables.
4. Plug the other end of the AC power cord into the wall socket.

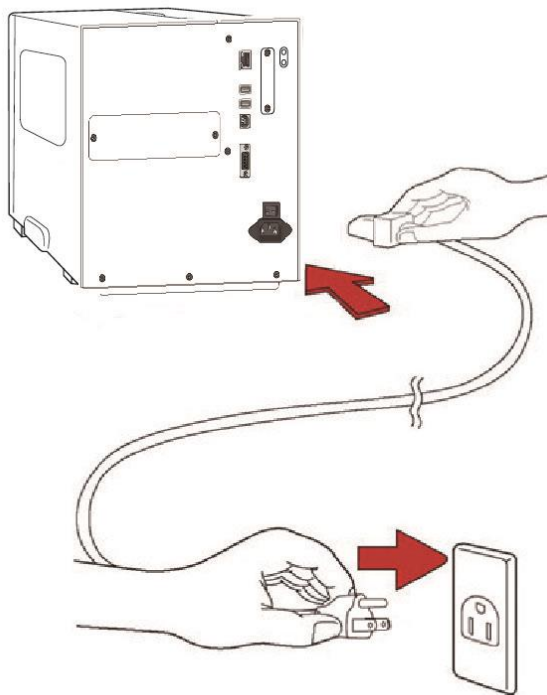

Warning: Do not plug the AC power cord with wet hands or operate the printer and the power supply in an area where they may get wet. Serious injury may result from these actions!

2.2 Turn on/off your printer

When your printer is connected to a host (a computer), it is good to turn on the printer before turning on the host and turn off the host before turning off the printer.

2.2.1 Turn on your printer

1. To turn on your printer, turn on the **Power Switch** as below. The “I” is the **ON** position.

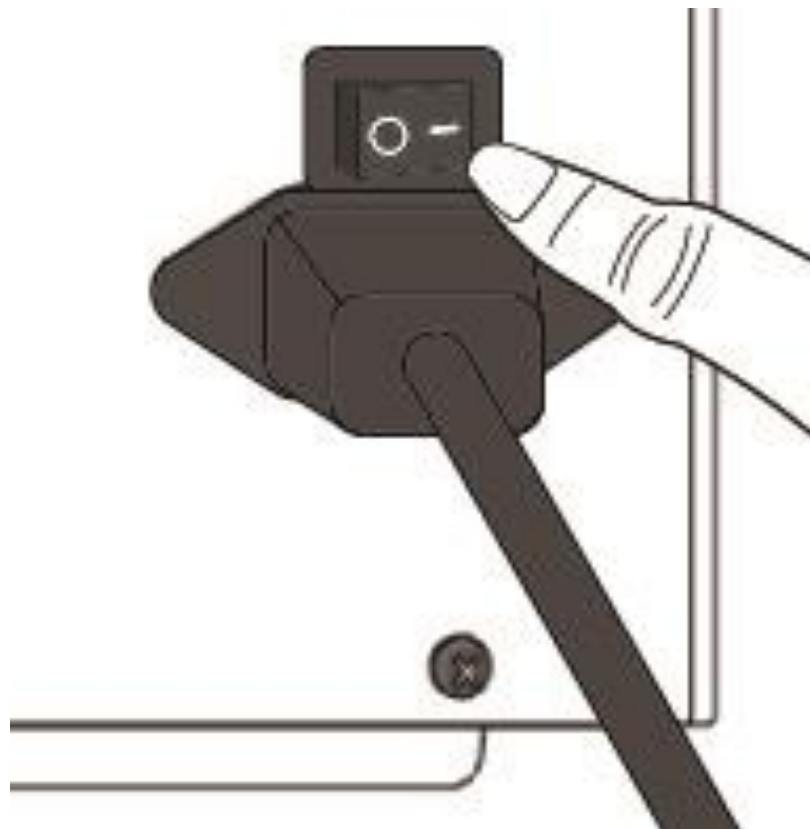

2. READY, MEDIA, and RIBBON LED are solid blue. Then, the READY LED turns off for a few seconds while the LCD screen shows the firmware version. The LCD screen will show Ready to print, and the READY LED will return to solid blue.

2.2.2 Turn off your printer

1. Make sure READY, MEDIA, and RIBBON are solid blue before turning off the printer.
2. To turn off your printer, turn off the **Power Switch** as below. The “O” is the **OFF** position.

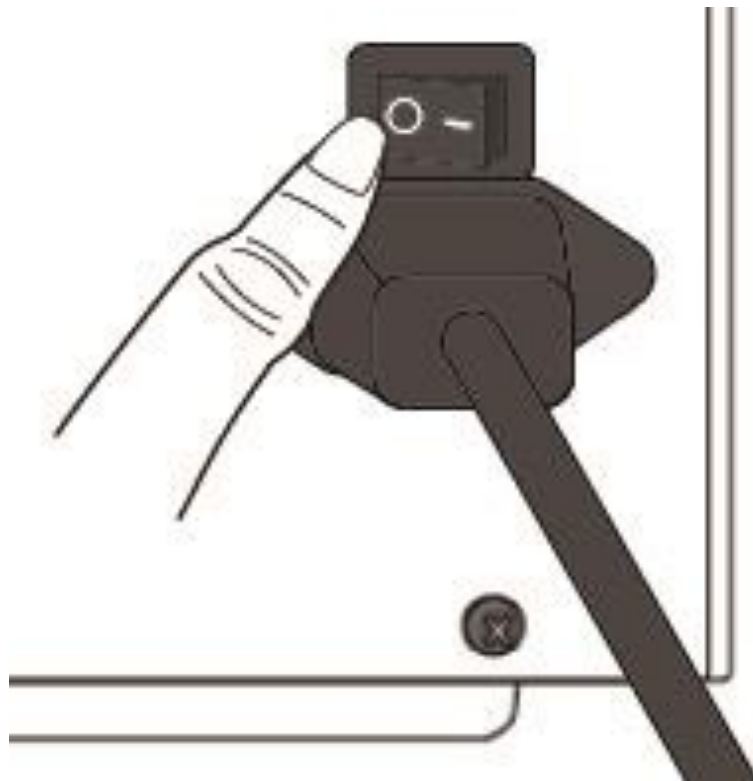

Caution: Do not turn off your printer during data transmission.

2.3 Load media



The iX4 Pro Series printers offer three different loading modes: standard, peel-off, or with a cutter.

- **Standard mode** allows you to collect each label freely.
- **Peel-off mode** peels backing material away from the label as it prints. After the label is removed, the following label prints.
- **Cutter mode** automatically cuts the label after it prints. There are rotate cutter and guillotine cutter types for cutting media.



Necessary The first time, use peel-off mode and cutter mode. Enable the PEELER INSTALLED or CUTTER INSTALLED setting in the front panel. For more information about panel setting, go to CH 3.1.1 [LCD Function Setting Procedure](#).

Thermal Transfer Media Loading Instructions

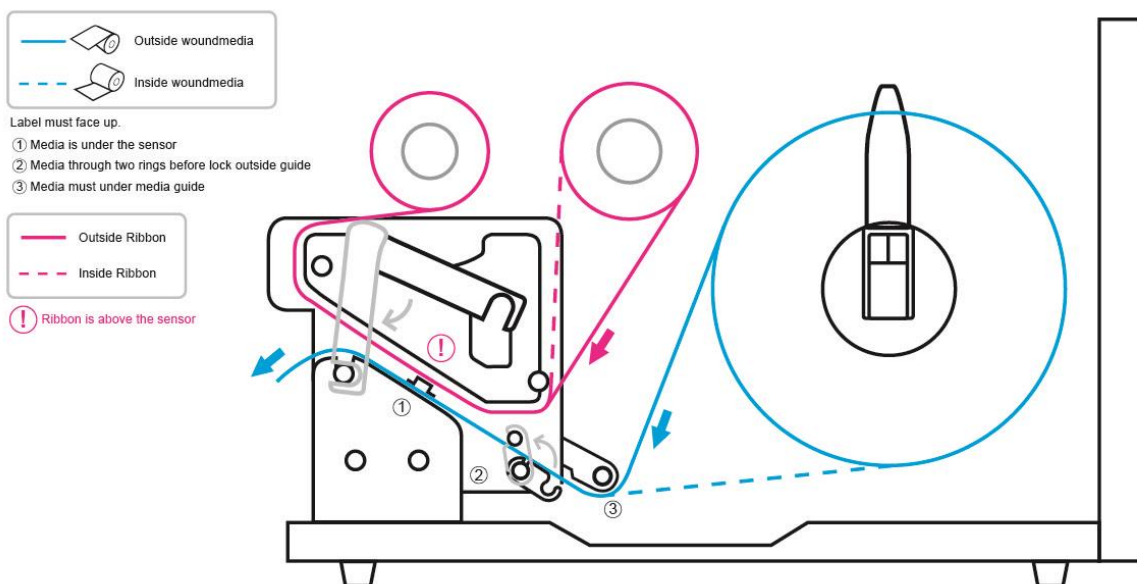

2.3.1 Prepare media

The inside wound and outside wound media roll can be loaded into the printer similarly. If the media roll is dirty during shipping, handling, or storage, remove the outside length of the media. It helps avoid dragging adhesive and dirty media between the printhead and platen roller.

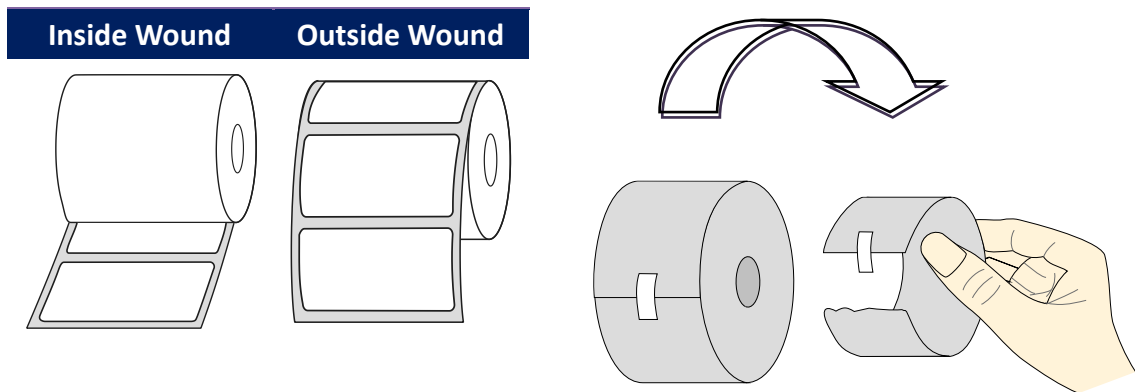

2.3.2 Placing media roll

Load Media In Standard Mode

- 1 Lift the top cover to expose the media compartment.

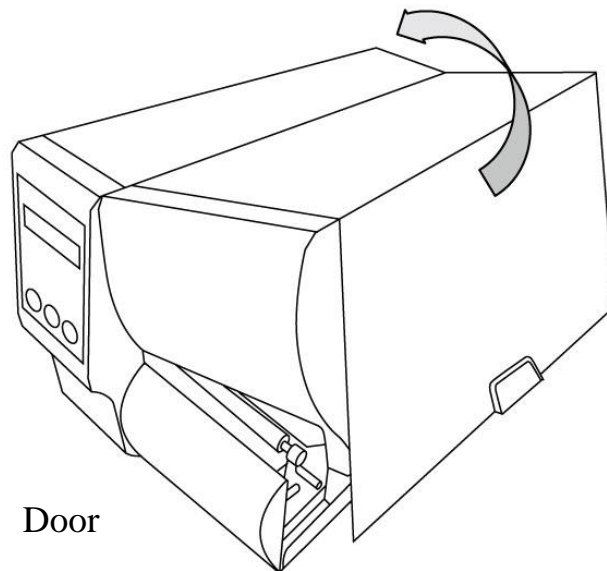

- 2 Insert the media roll into the media supply spindle and move the media guide to the inside.

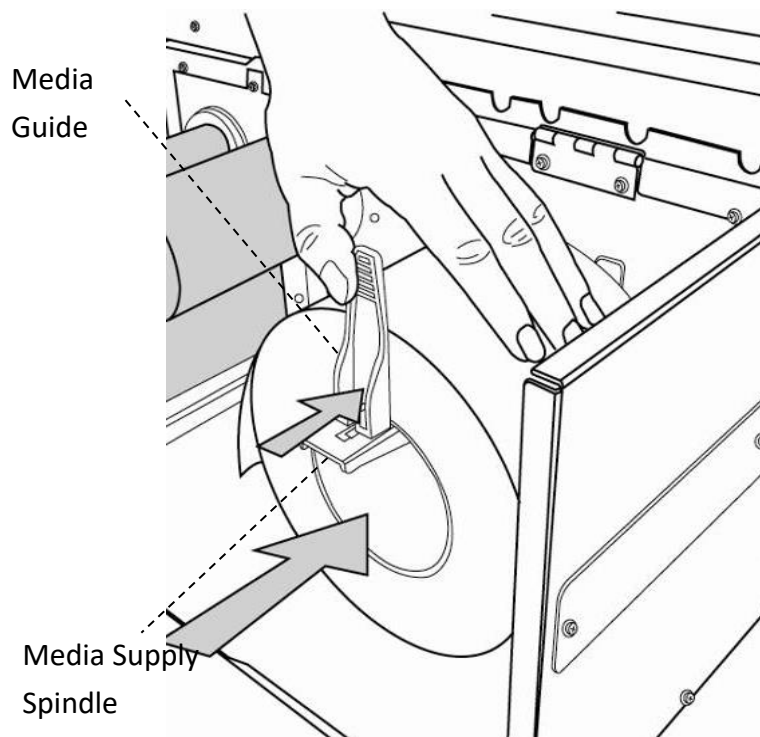

3. Turn the head latch counterclockwise and open the outside media guide counterclockwise for media insert.

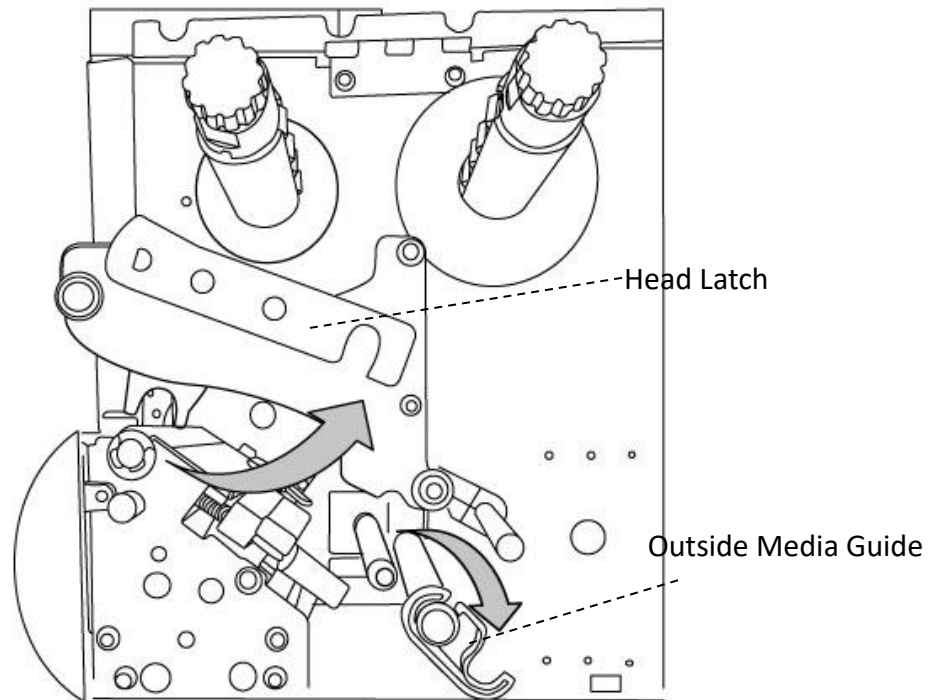

4. The label must face up when leading the media through the print head module. Media is under "media guide" and through two rings before locking "Outside Media Guide." Then, under the paper sensor guide module and over the roller.

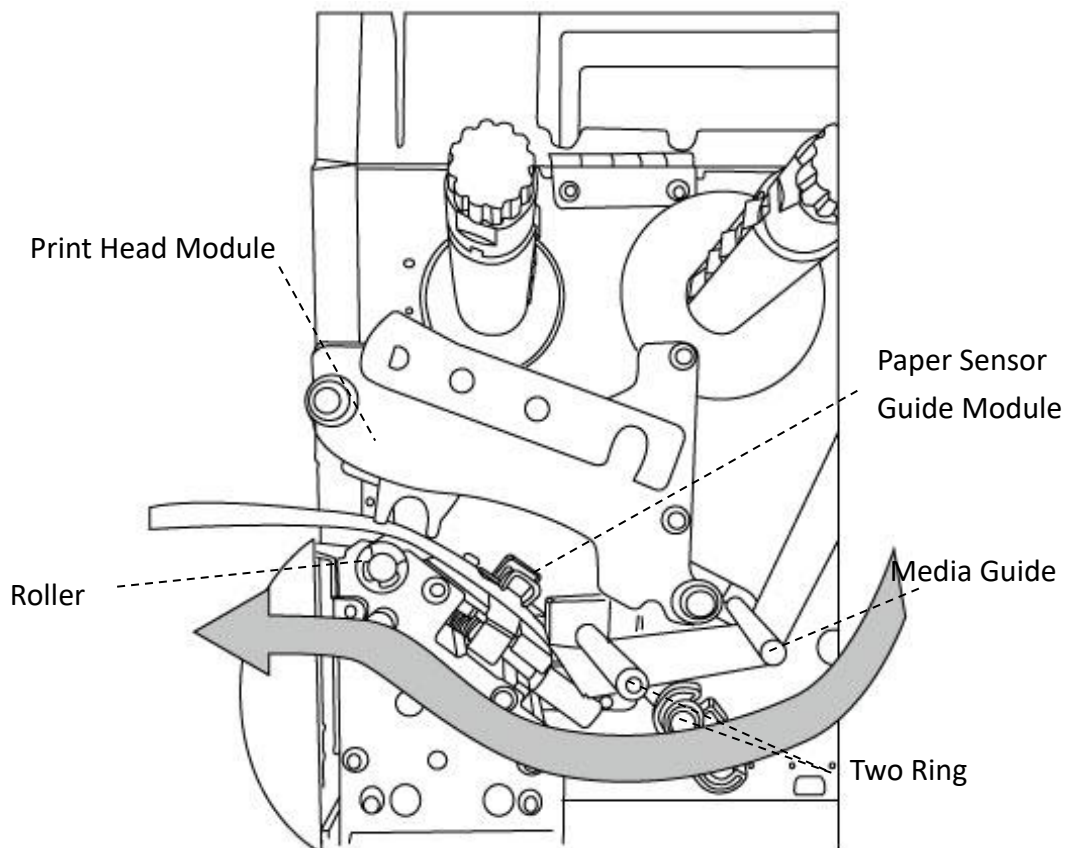

5. Return the outside media guide and hook the head latch.

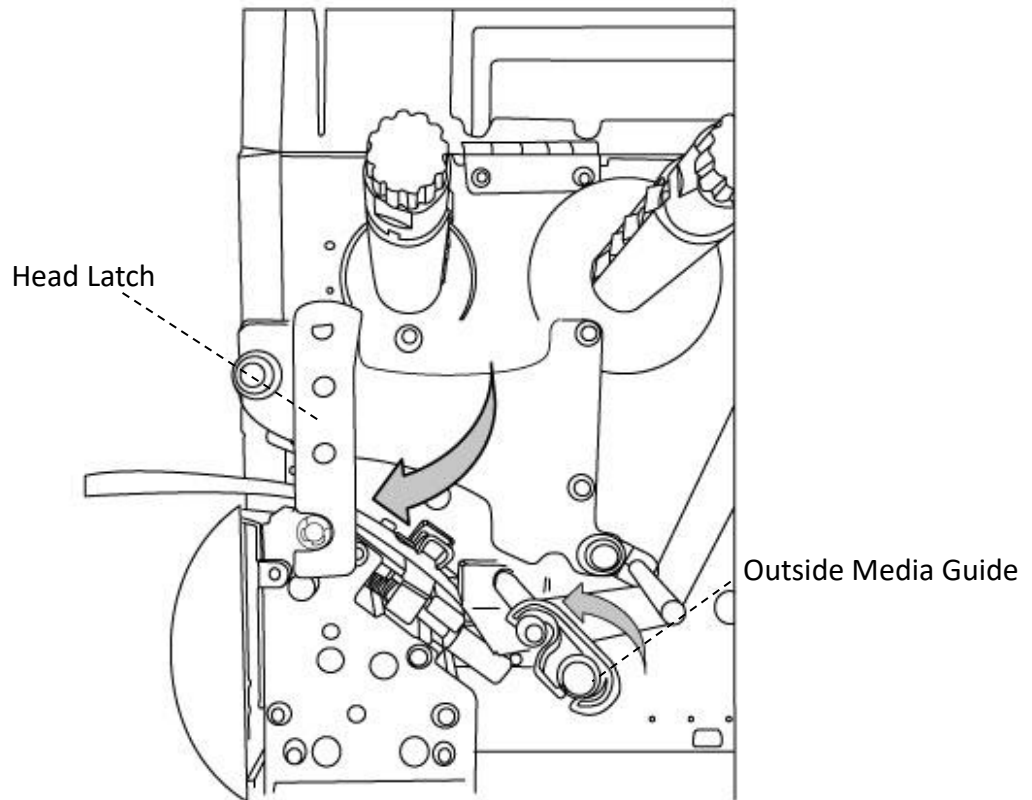

6. Close the top cover.

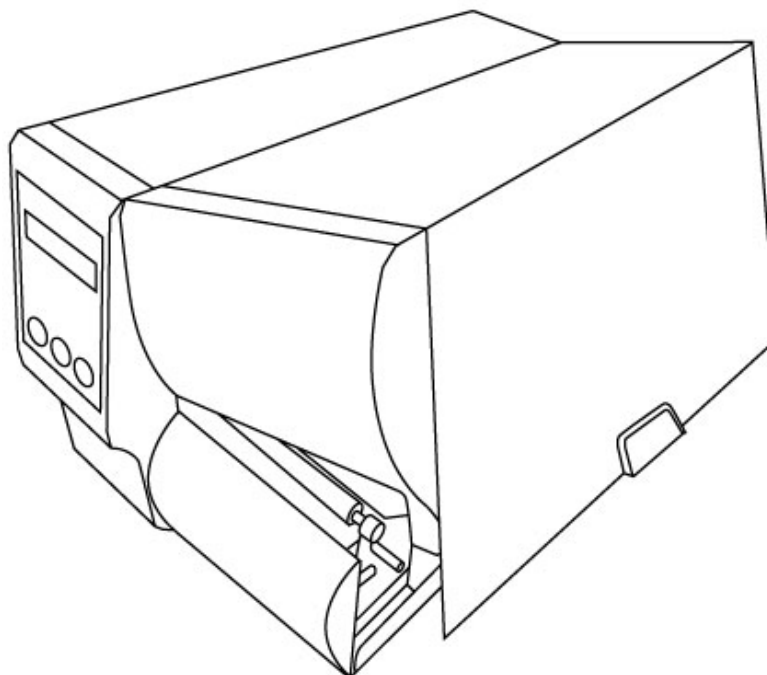

7. Press the FEED button if the printer is already on.

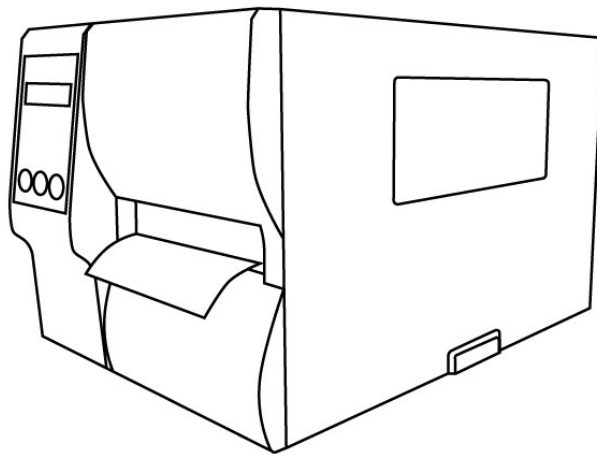

Important

After the media is loaded, please perform [media calibration](#) to calibrate the label sensor before printing.



Note: Ensure the die-cut media's label length is at least 25mm or longer for direct thermal printing in tear-off mode with perforation.

Load Media In Peel Off Mode

Steps 1 to 3 are similar to “Standard Mode”.

1. Lift the top cover to expose the media compartment.
2. Insert the media roll into the supply spindle and move the media guide inside.
3. Turn the head latch counterclockwise and open the outside media guide for media insert.
4. From the leading end of the media roll, remove enough labels to expose 6-inches of backing paper.

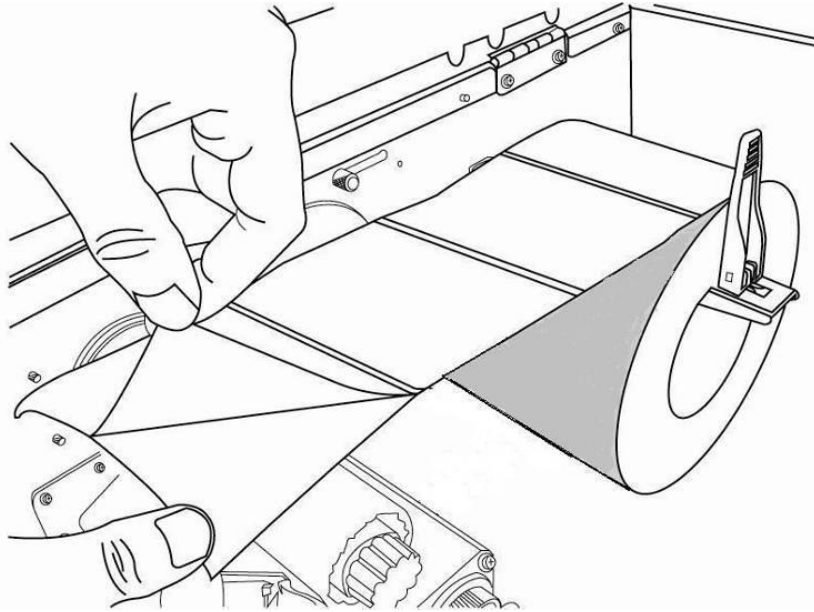

5. Lead the media backing paper under the print head module; refer to standard mode step 4 for more specific leading media.

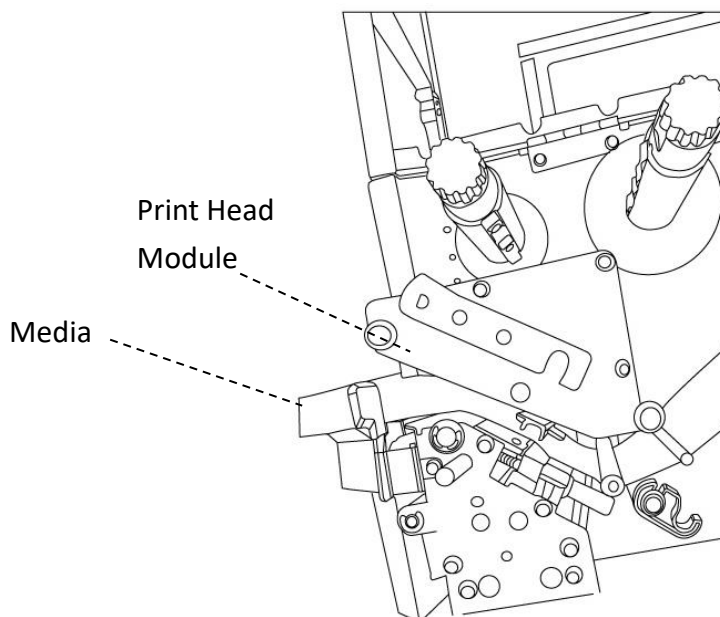

6. Push down the peel-off mechanism release lever and lead the media backing paper behind the dispenser (peeler) module.

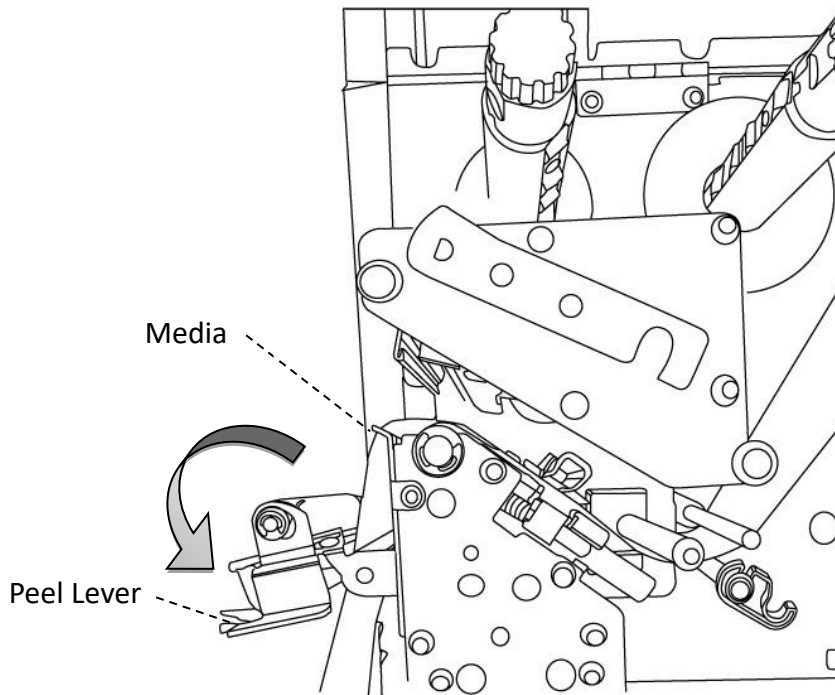

7. Close the dispenser (peeler) module using the peel-off mechanism release lever. Return the outside media guide and hook the head latch.

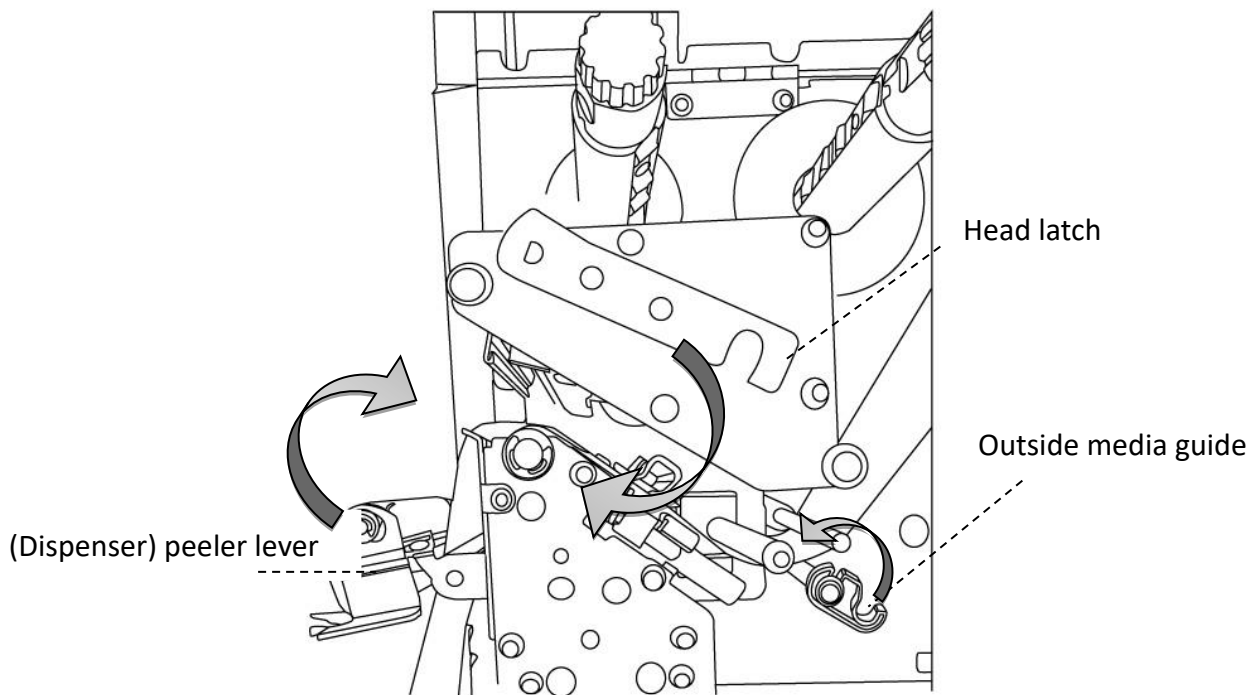

8. Close the top cover and turn on the printer or press the FEED button if the printer is already on.

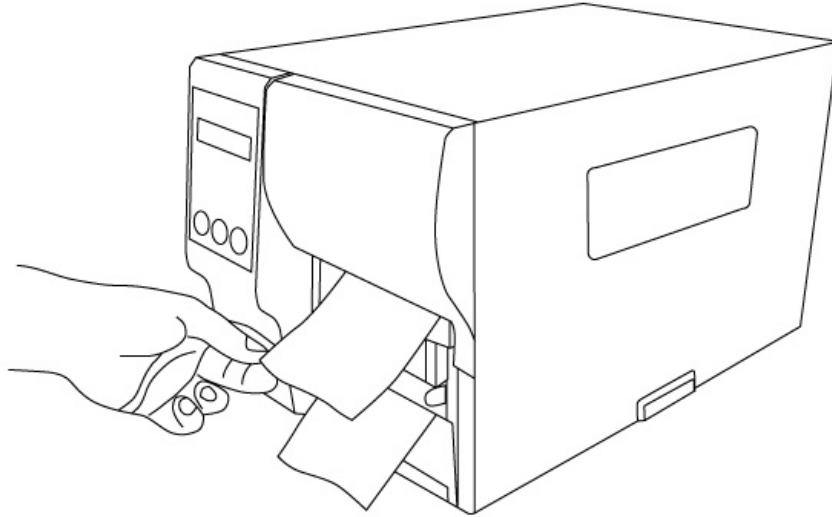

Important

After the media is loaded, please perform [media calibration](#) to calibrate the label sensor before printing.

Load Media In Rotary Cutter Mode

Steps 1 to 3 are similar to “Standard Mode”.

1. Lift the top cover to expose the media compartment.
2. Insert the media roll into the supply spindle and move the media guide inside.
3. Turn the head latch counter-clockwise and turn on the outside media guide.
4. Insert the media under the print head module and the paper sensor guide over the roller. For more specific leading media, refer to the standard mode.

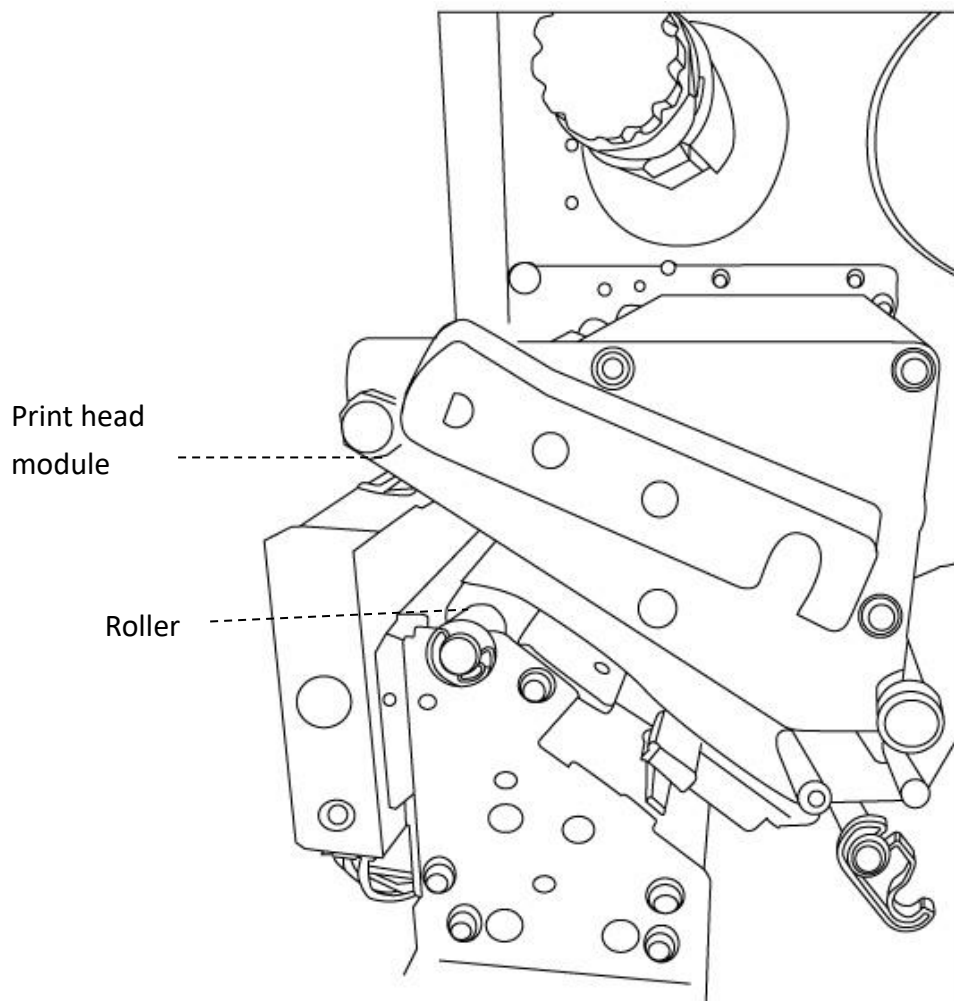

- Return the outside media guide and hook the head latch.

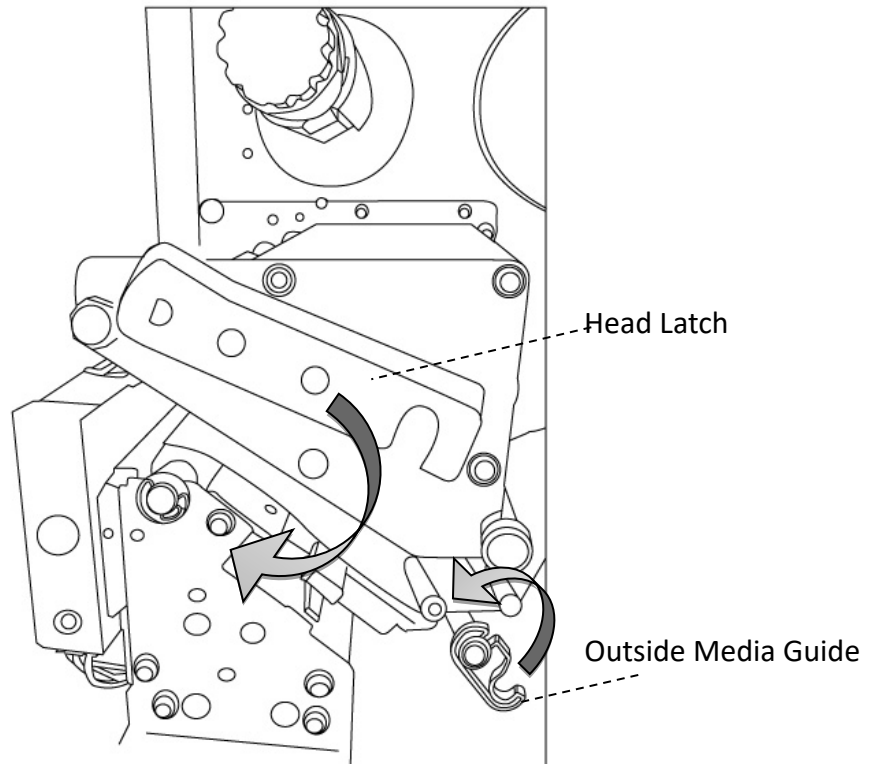

- Close the top cover and turn on the printer or press the FEED button if the printer is already on. The printer will then feed the labels through the cutter automatically.

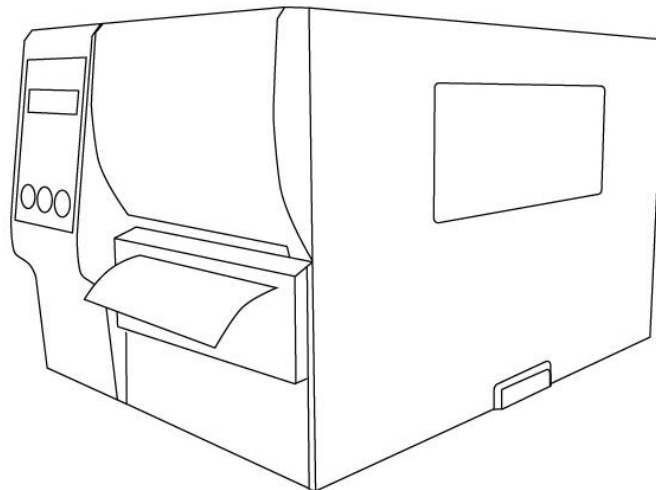

Important

After the media is loaded, please perform [media calibration](#) to calibrate the label sensor before printing.

Load Media In Guillotine Cutter Mode

Steps 1 to 3 are similar to “Standard Mode”.

1. Lift the top cover to expose the media compartment.
2. Insert the media roll into the supply spindle and move the media guide inside.
3. Turn the head latch counterclockwise and turn on the outside media guide.
4. Insert the media into the print head module and under the paper sensor guide. For more specific leading media, refer to the standard mode. Unhook the cutter module and pull down the mechanism to release the lever from the Guillotine Cutter and lead media through the Guillotine Cutter.

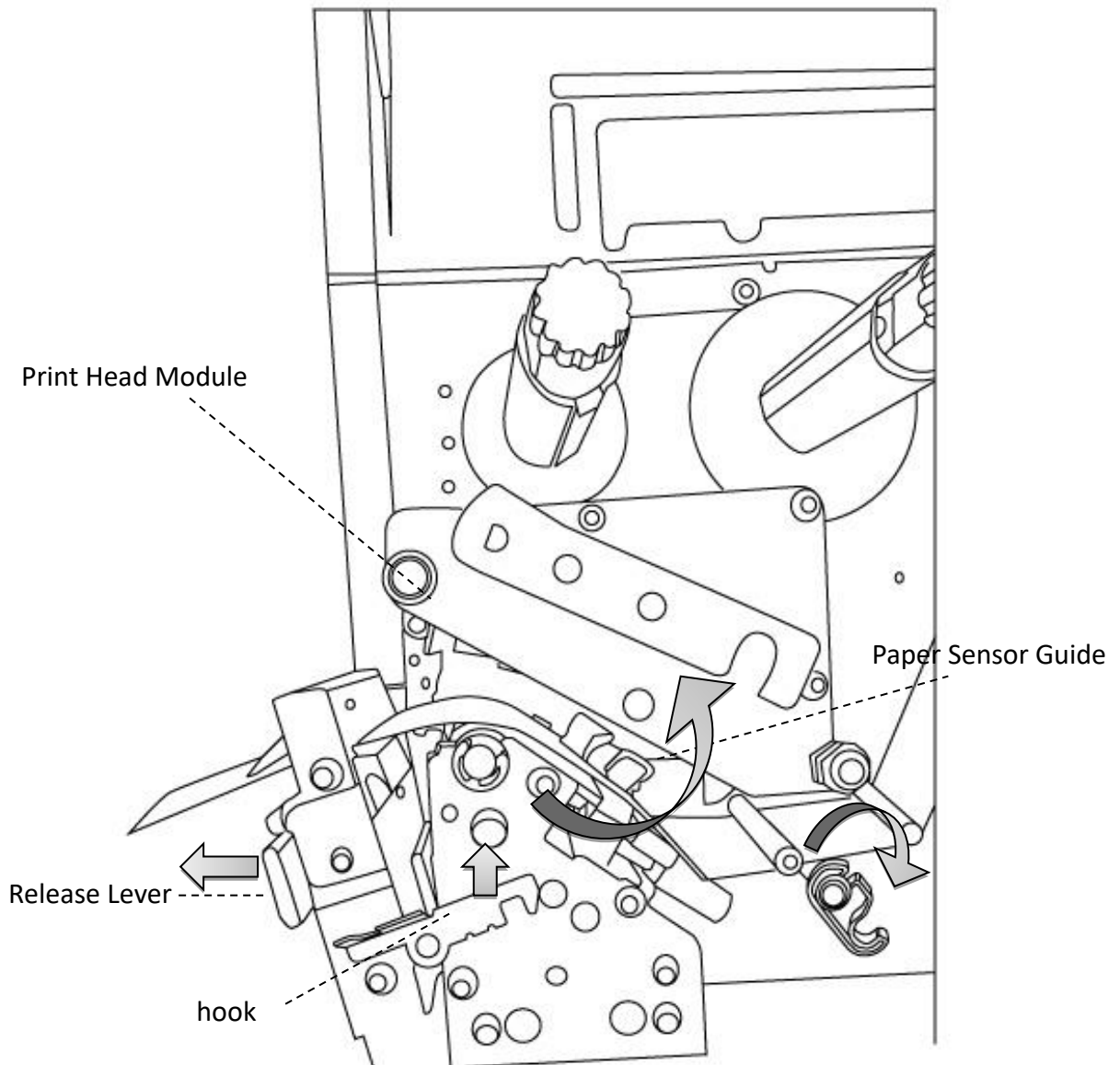

5. Push back the Guillotine Cutter, return the outside media guide, and hook the head latch.

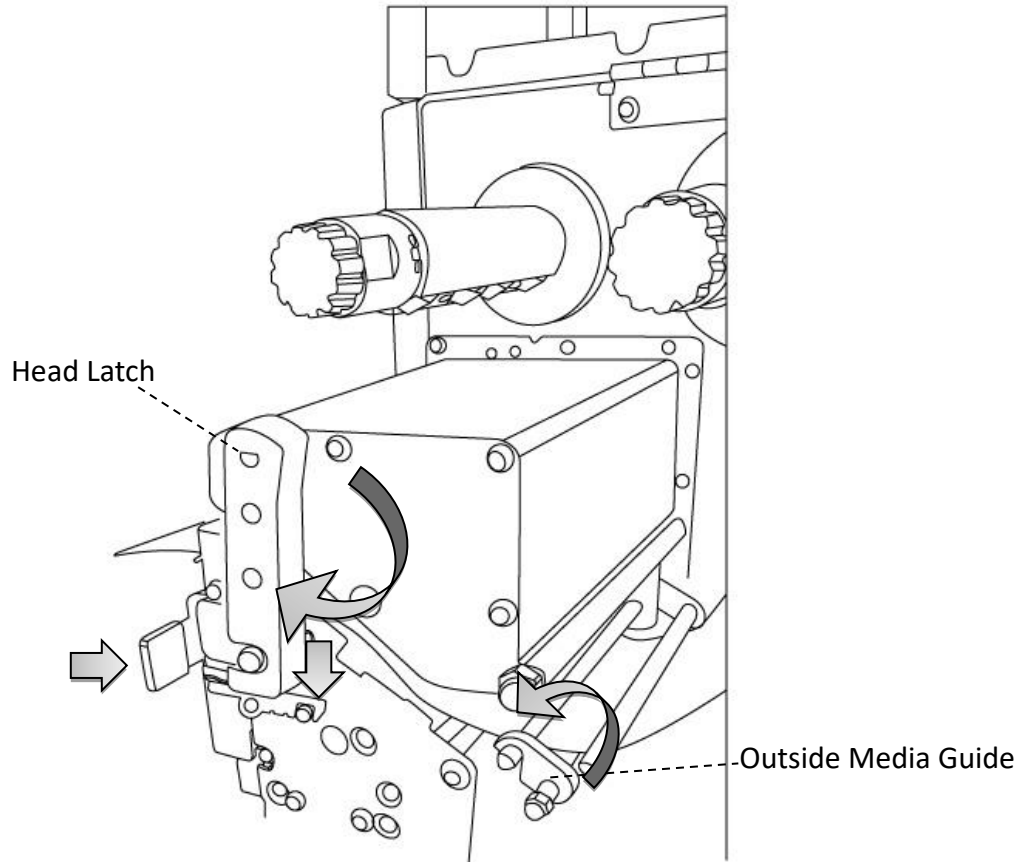

6. Close the top cover and turn on the printer or press the FEED button if the printer is already on. The printer will then feed the labels through the cutter automatically.

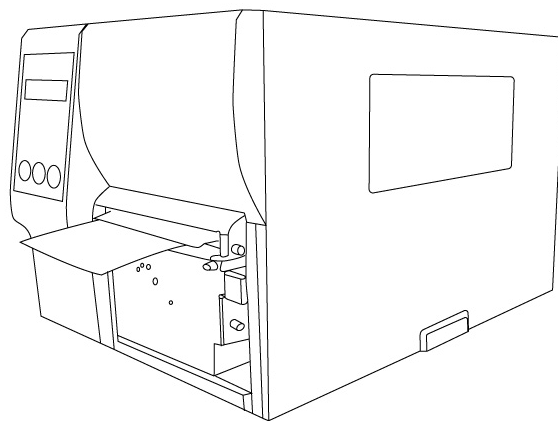



Important

After the media is loaded, please perform [media calibration](#) to calibrate the label sensor before printing.

2.3.3 Media types

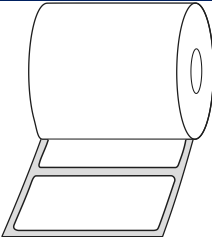
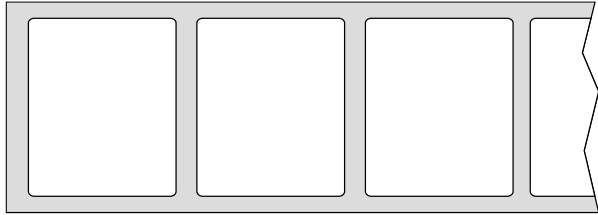
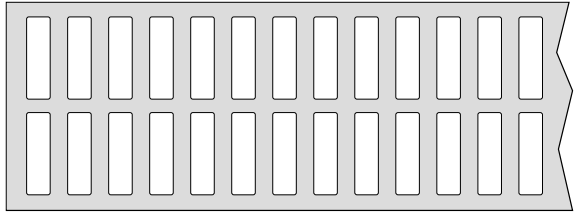
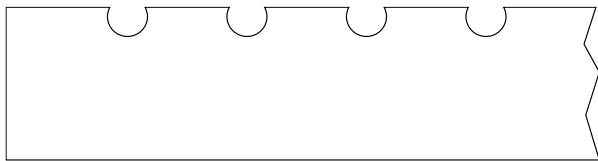
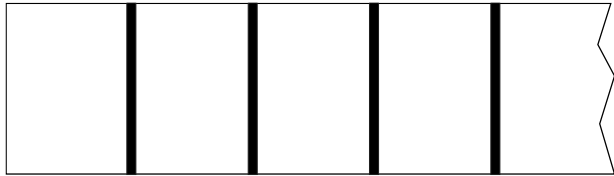
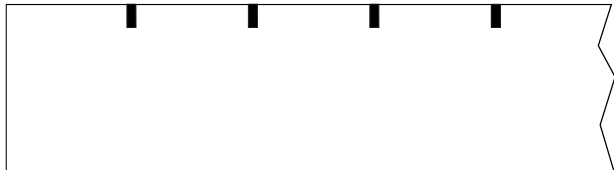
Your printer supports various media types, including non-continuous, continuous, and fanfold. The following table provides details about them.

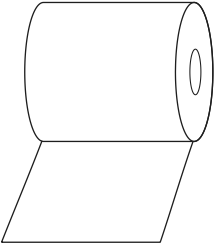
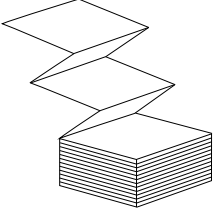
Media Type	Looks Like	Description
Non-Continuous Media	     	<p>Non-continuous media is the typical media for barcode printing. Labels and tags are made of various materials, such as paper, fabric, or cardstock, and are separated by gaps, holes, notches, or black marks. Many labels are self-adhesive with liners, while some are linerless.</p>

Media Type	Looks Like	Description
Continuous Media		<p>Continuous media does not have gaps, holes, notches, or black marks. It allows you to print data anywhere on the media. A cutter may be used to split labels. Mainly, it is used for direct thermal printing.</p>
Fanfold Media		<p>Fanfold media is in continuous form but can be used as non-continuous media because folds separate its labels. Some fanfold media also has black marks or liners.</p>
Tag Media		<p>Tag media is usually made from heavy paper, with a center hole to index. It does not have adhesive or a liner, and it is typically perforated between tags. The media may also have black marks or other separations.</p>

2.4 Load Ribbon



The following steps only apply to thermal transfer printing mode.

Direct thermal does not need a ribbon to be installed.

iX4 Pro Series printers apply to both inside and outside wound ribbons. Printers can switch automatically.



Note

- Media and ribbon types should be matched to provide optimal print results.
- Always use a ribbon that is wider than the media to protect the print head from wear.

2.4.1 Placing Ribbon Roll

1. Lift the top cover to expose the media compartment.

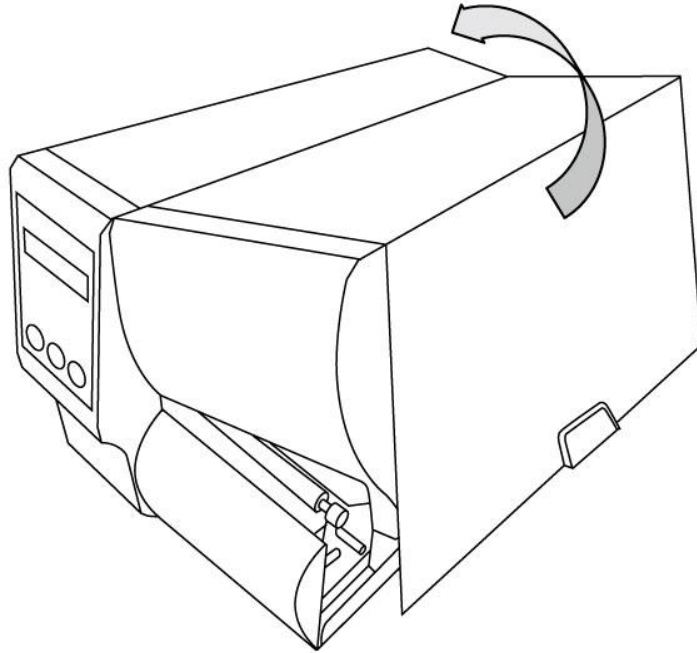

2. Turn the head latch counterclockwise.

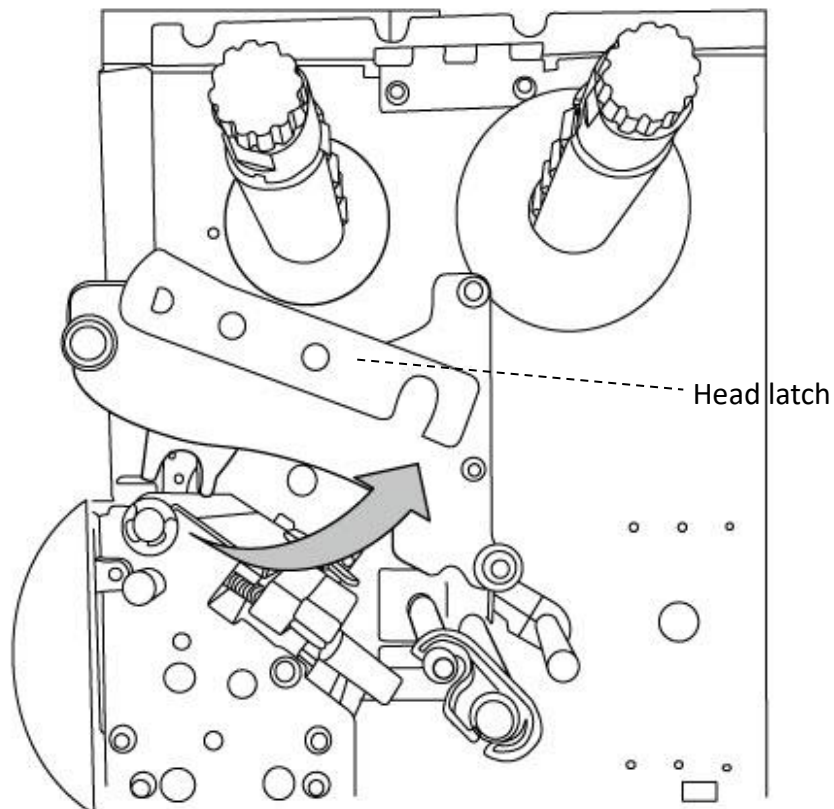

3. Unwrap the ribbon and separate the ribbon roll from the bare core. Insert the ribbon roll onto the ribbon supply spindle.

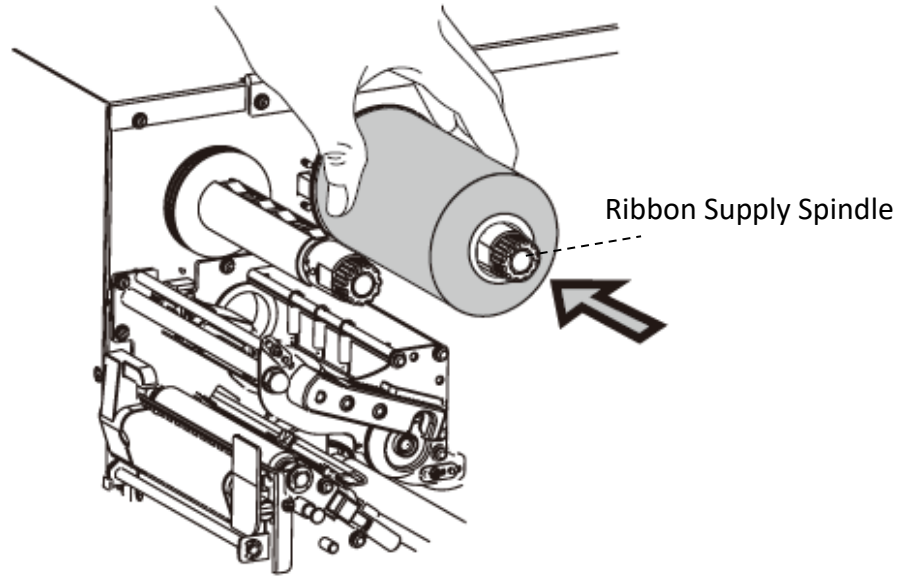

4. Lead the ribbon through the print head module. Attach the edge of the ribbon onto the bare core and wind it a bit onto the core. Make sure the coating side of the ribbon is face down.

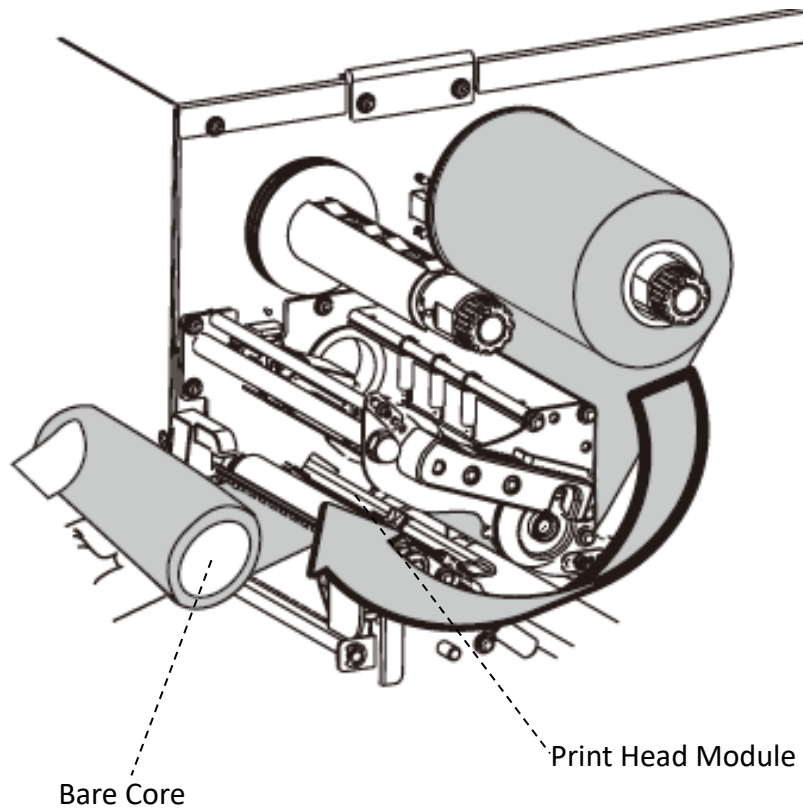

5. Insert the core onto the ribbon pick-up spindle. Turn the pick-up spindle to ensure the ribbon is tightly wound.

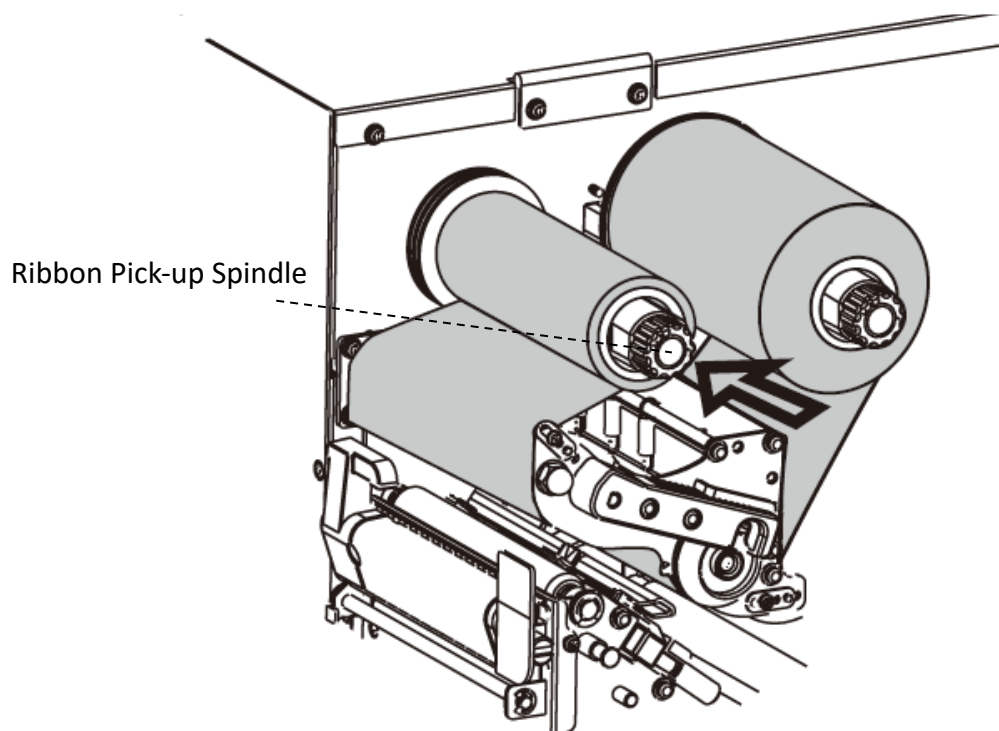

6. Close the top cover and turn on the printer.

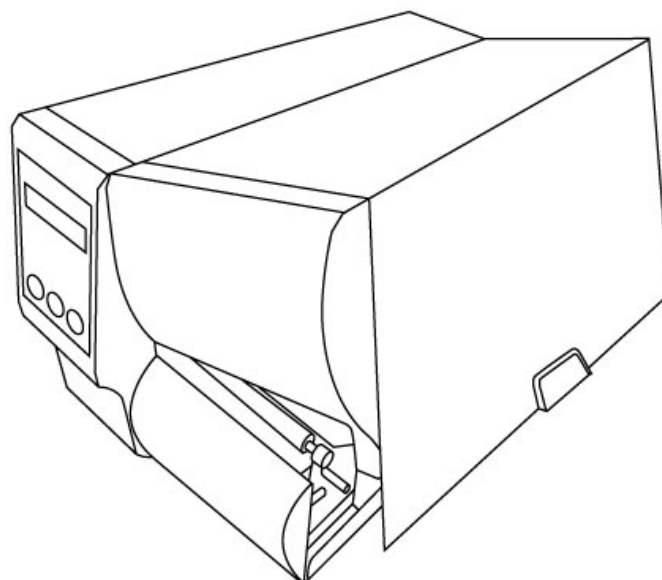

3 Printer operation

This chapter provides more specific information about printer operation.

3.1 Front Panel

Change settings via buttons on the panel:

Buttons	Function
PAUSE+CANCEL	Press to enter setting mode. Press again to exit setting mode and return to normal mode.
FEED	Press to show the following parameter.
PAUSE	Press to show the next setting item.
CANCEL	Selects and saves a parameter to permanent FLASH memory. Unless changed via panel or command, the parameter is saved even if you restart the printer.



Warning: Do not change settings when *printing or sending printing data*.

3.1.1 LCD Function Setting Procedure

The following procedure is an example of setting procedure to direct thermal printing mode:

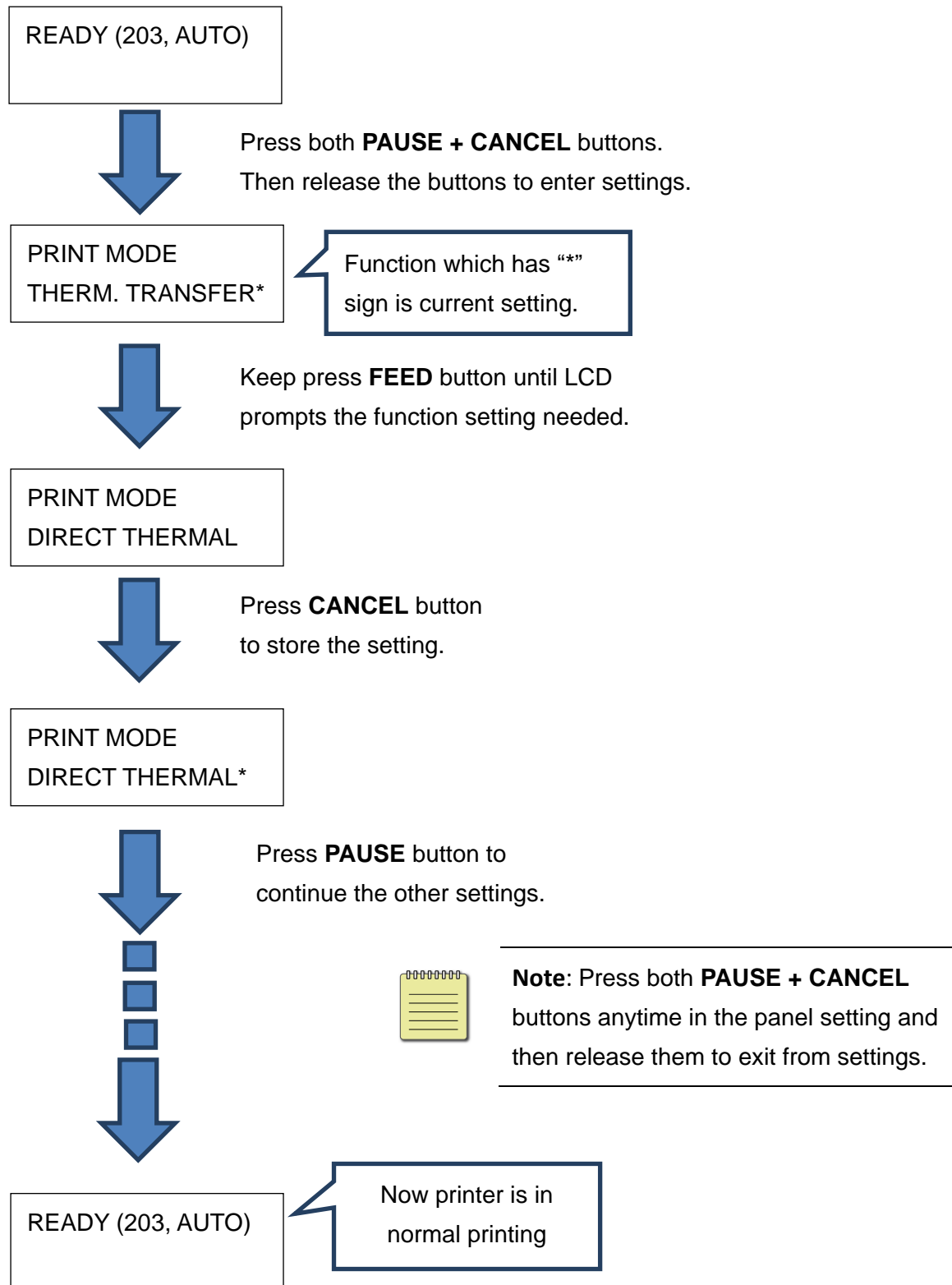

Press **PAUSE + CANCEL** over **5 seconds** to set different languages.

Item	Range	Factory Default
LANGUAGE	ENGLISH, FRENCH, GERMAN, ITALIAN, SPANISH, PORTUGUESE,	ENGLISH

Press **PAUSE + CANCEL** for less than 1 second to set the printer function.

NO.	Item	Range	Factory Default	Remarks
1	PRINT MODE	THERM. TRANSFER DIRECT THERMAL	THERM. TRANSFER	(Restart printer after change setting)
2	CALIBRATION MODE	INTELLI PRINT SMART PRINT	INTELLI PRINT	INTELLI PRINT: Install labels, latch print module, press the FEED button once, and then the printer will feed 1-2 labels to detect the next gap / black mark before printing. SMART PRINT: Print from the first label immediately according to the label length setting. Carefully align the label's bottom edge at the tear-off position before printing. (Restart printer after change setting)
3	CONTROL CODE SET	STANDARD ALTERNATIVE ALTERNATIVE 2	1 STANDARD	Available only in PPLA printer language. (Restart printer after change setting)
4	CUT OFFSET	PEEL -015 ~ 015 mm	000 mm	To adjust cut and peel positions.

5	TPH VER OFFSET	-009~009 mm	000 mm	Adjust the offset of the vertical print position.
6	RECOVER PRINT	ENABLE, DISABLE	ENABLE	Will not reprint after recovering from media-out or ribbon-out errors.
7	CUTTER INSTALLED	NO YES	NO	(Restart printer after change setting)
8	PEELER INSTALLED	NO YES	NO	
9	STANDALONE FORM FONT	NO YES	NO	Available only in PPLB printer language. (Restart printer after change setting)
10	WIN. CON. LEN.	0 ~ 254 mm	000 mm	Available only in Windows with bundled printer driver and for continuous media.
11	SPEED	2 ~ 8 IPS (iX4-250 Pro) 2 ~ 6 IPS (iX-350 Pro)	6 IPS (iX4-250 Pro) 5 IPS (iX4-350 Pro)	
12	COUNTING	DOWN UP	DOWN	
13	MEDIASENSER TYPE	SEE-THROUGH REFLECTIVE	SEE- THROUGH	Select different media types. After changing the sensor setting, make sure to calibrate before printing. (Restart printer after change setting)
14	BACK FEED	DISABLE ENABLE	ENABLE	Available only in PPLA and PPLB printer languages. Once "ENABLE" is selected, the printer enters the BACK DISTANCE setting.
15	BACK DISTANCE	10~40 mm	22 mm	Available only when BACK FEED is enabled.

16	BASE DARKNESS	-28~28	0	
17	DARKNESS	0~30	16	To select darkness.
18	BAUD RATE	2400 / 4800 / 9600 / 19200 / 38400 / 57600 / 115200	9600	It should be as exact as the host's setting. (Restart printer after change setting)
19	PARITY (RS232)	NONE ODD EVEN	NONE	It should be as exact as the host's setting. (Restart printer after change setting)
20	LENGTH (RS232)	8 DATA BITS 7 DATA BITS	8 DATA BITS	It should be as exact as the host's setting. (Restart printer after change setting)
21	CLEAR FLASH	NO YES	NO	When "YES" is selected, all the label forms, soft fonts, and graphics stored will be deleted. (Restart printer after change setting)
22	SETTING PRIORITY	COMMAND/ LCD PANEL	COMMAND	It is choosing the priority of LCD settings. It decides which setting method - by command or by LCD panel, is prior.
23	EMULATION	AUTO PPLA PPLB PPLZ	AUTO	(Restart printer after change setting)
24	BUZZER	DISABLE ENABLE	ENABLE	
25	STANDBY	DISABLE 1 MINUTE 2 MINUTES 5 MINUTES	DISABLE	

10 MINUTES

20 MINUTES

30 MINUTES

			LAST SAVED:
			NO.1~15, NO.17, NO.22, NO.24~25, and language will be loaded.
		LAST SAVED	FACTORY:
26	LOAD DEFAULTS	FACTORY	NO.1, NO6, NO9, NO11, NO14~15, NO17, NO.27~30 will be loaded.
		NETWORK	NETWORK:
			NO.27~30 will be loaded.
			(Restart printer after change setting)

Ethernet settings and parameters

NO.	Item	Range	Factory Default	Remarks
27	DHCP	DISABLE ENABLE		<p>If the printer has been connected to a router, the DHCP server will automatically assign the IP address after powering it.</p> <p>If the printer is not connected to a router, with DHCP disabled, IP ADDRESS, SUBNET MASK, and DEFAULT GATEWAY settings will be available on LCD.</p> <p>Whenever DISABLE is changed to ENABLE, LCD will prompt "ETHERNET CARD UPDATE FINISH..."</p> <p>Then please reboot the printer.</p>
28	IP ADDRESS	xxx.xxx.xxx.xxx	xxx range:0~255	<p>When DHCP is disabled, the default IP address is 192.168.1.100.</p> <p>If the "_" sign appears, the DHCP setting is disabled. On the contrary, the DHCP setting is enabled.</p> <p>1. <u>FEED/CONFIG</u> : Change contents. (ex. from 000.000.000.000 to 255.255.255.255)</p> <p>2. <u>PAUSE/CALIBR</u> : Shift "_" sign position. (ex. from <u>255.255.255.255</u> to 255.255.255.255)</p> <p>3. <u>CANCEL/RESET</u> : Select the following function setting. ("_" sign must be at the third digit of each parameter, for example, <u>xxx</u>).</p> <p>4. To change IP ADDRESS or SUBNET MASK, enter the DEFAULT GATEWAY setting, and press the CANCEL button once; LCD will prompt "ETHERNET CARD UPDATE FINISH..."</p> <p>Then, reboot the printer.</p> <p>For more information on Ethernet settings, please refer to Ethernet User's Guide.</p>
29	SUBNET MASK	xxx.xxx.xxx.xxx		
30	DEFAULT GATEWAY	xxx.xxx.xxx.xxx		
31	MAC ADDRESS	Read-only		

WiFi module (Option)

Item	Range	Remarks
WIFI SSID	Read-only	The WIFI module is an option for the iX4 Pro Series. Connect the printer to the PC and set the WIFI module with the print tool. To have more information, please refer to the Print Tool user guide.
WIFI IP ADDRESS	Read-only	
WIFI SUBNET MASK	Read-only	
WIFI GATEWAY	Read-only	
WIFI MAC ADDRESS	Read-only	

3.2 Printing Media Calibration & Configuration

Before calibration, be sure the media and ribbon (for thermal transfer printing) have been loaded correctly. The label sensor must be appropriately located to index labels' gaps/ notches/ holes. After the media is loaded, please perform media calibration to calibrate the label sensor in advance. For printers without LCD, please see indicators.

1. Turn off the printer
2. Press and hold the **PAUSE** button and turn on the power.
3. When "CALIBRATION ..." is displayed on the LCD, and both READY and MEDIA indicators blink, release the **PAUSE** button.
4. The printer feeds 1 or 2 blank labels.
5. When "READY" is displayed, the READY and MEDIA indicators stop blinking but remain illuminated.

3.3 Printing a Configuration Report

To perform a self-test and print a configuration report, helping to check the printer's print quality and internal settings. Steps as below:

1. Turn off the printer.
2. Load media and ribbon.
3. Press and hold the **FEED** button while turning on the power.
4. When "SELF-TEST ..." is displayed on the LCD, release the **FEED** button.
5. The printer now prints out a configuration report. (as the sample on the next page) All characters will be printed in 2 columns: the right shows characters received from your system, and the left shows the corresponding hexadecimal values of the characters. It allows users or engineers to verify and debug the program.

For printers without LCD, please see indicators.

1. Version Information

The firmware version and its build date.

2. Standard RAM

Total SDRAM size.

3. Available RAM

RAM can be used.

4. Flash Type

The flash memory type and size.

5. Available Flash

Flash can be used.

6. No. of DL soft fonts (FLASH)

The number of fonts is downloaded in Flash.

7. No. of DL soft fonts (RAM)

The number of fonts is downloaded in RAM.

8. No. of DL soft fonts (HOST)

The number of fonts is downloaded in USB HOST.

9. H. Position Adjust

Move the print position horizontally.

10. Sensor Type

The media sensor type is a reflective sensor.

11. Label-less Calibration Value

Check if a label-less calibration has been performed on the printer. If not, the value is 0000.

12. RTC Time

The date and time of the real-time clock (RTC). The default format is month/day/year (hour:minute: second). If your printer has a built-in RTC, the RTC time shows here.

13. Max Label Height

The max label length you can print at a time. For 200 dpi models, it is 100 inches; for 300 dpi models, it is 50 inches.

14. Print Width

The print width is in dots.

15. Lab Len (Top to Top)

For non-continuous media, it is the length between the tops of two labels.

16. Speed

The speed of printing. The unit is an inch per second (IPS).

17. Darkness

The current darkness.

18. Print Method

It is either thermal transfer (TT) or direct thermal (DT) printing. TT requires ribbons, and DT doesn't.

19. Print Length

The total print length.

20. Cut Count

It counts the times the cutter cuts.

21. RS232 Protocol

It lists RS-232C settings in the following order: baud rate, data length, parity check, stop bit, and flow control.

22. Code page

The character set table.

23. Media

The media type in use.

24. Calibration mode

There are Intelli mode or Smart mode.

Intelli mode: Install labels, latch print module, press FEED button once, and then the printer will feed 1-2 labels to detect next gap / black mark before printing. If the FEED button is not pressed, the printer will feed 1-2 labels automatically before printing.

Smart mode: Print from the first label immediately according to the label length setting. Carefully align label bottom edge at the tear-off position before printing.

25. Backfeed Enabled/Disabled

Turn backfeed on or off during the printing process. When enabled, the printer moves the paper forward in a predefined length 1 second after printing, and pulls the paper back in a predefined length once the printing begins again. When it is disabled, the printer won't move the paper at all.

26. Cutter Enabled/Disabled

Enable or disable the cutter during the printing process.

27. Dispenser (Peeler) Enabled/Disabled

Enable or disable the dispenser (peeler) during the printing process.

28. Cutter/Dispenser (Peeler) Offset

Move the cutting line or the peeling position forward or backward. The value in the angle brackets is the offset unit.

29. IP Address

The static IP address of the printer. The default value is "192.168.1.1".

30. Subnet Mask

The manually specified subnet mask of the printer. The default value is "255.255.255.0."

31. Gateway

The manually specified gateway of the printer. The default value is "0.0.0.0."

32. MAC Address

The unique address assigned to the printer that connects to the internet.

33. DHCP

When DHCP is enabled, it assigns an IP address to the printer automatically.

34. DHCP Client ID

It is an arbitrary value sent to the DHCP server to reserve an IP address for the printer.

35. DHCP Host Name

The name of a DHCP client.

36. SNMP

When it is enabled, the host gets or sets parameters registered as SNMP entities.

37. Socket Communication

When it is enabled, the host communicates with the printer via the socket.

38. Socket Port

The socket number of the printer.

39. IPv6 Mode

It determines how you get the IPv6 address of your printer. There are three modes: MANUAL, DHCPv6 or AUTO.

40. IPv6 Type

It is the IPv6 address type of your printer. There are four types: NONE, NORMAL, EUI and ANY.

41. IPv6 Address

The static IPv6 address of your printer.

42. Link Local

The IPv6 address that used in a network segment. It is allocated automatically.

43. Product SN

The serial number of product.

44. USB SN

The Serial number of USB host.

45. CG Enable

Printer is able to use True Type font.

46. TPH and Cutter Offset

For developers to debug.

47. Reflective Sensor Gap Calibration

For developers to debug.

48. See-Through Sensor Gap Calibration

For developers to debug.

49. Reflective Sensor Profile

For developers to debug.

50. See-Through Sensor Profile

For developers to debug.

51. Ribbon Sensor Profile

For developers to debug.

52. Reflective Sensor Offset

For developers to debug.

53. See-Through Sensor Offset

For developers to debug.

54-58. Font Image

You can use them as the reference to check your label font.

59-64. TPH Test Pattern

You can use them to check broken pins on the printhead.

If your printer has a Wi-Fi module, your PPLB configuration label will contain the following entries:

```
WLAN FW VERSION: 1.00_____ 1
                DATE: 2015.05.26_____ 2
WLAN IP ADDRESS: 0.0.0.0_____ 3
WLAN SUBNET MASK: 0.0.0.0_____ 4
WLAN GATEWAY: 0.0.0.0_____ 5
WLAN MAC ADDRESS: 00-80-92-4F-77-35_____ 6
WLAN DHCP: AUTO_____ 7
WLAN DHCP HOSTNAME: 00-80-92-4F-77-3_____ 8
                  : 5
WLAN SOCKET PORT: 9100_____ 9
WLAN SSID: WIRELESS PRINTER_____ 10
WLAN MODE: Infrastructure_____ 11
WLAN COUNTRY CODE: USA_____ 12
WLAN CHANNEL: AUTO_____ 13
WLAN NETWORK AUTHENTICATION: Open_____ 14
WLAN WEP: OFF_____ 15
```

1. FW Version

WLAN board firmware version.

2. Date

WLAN board firmware version date.

3. IP Address

The IP address of your printer. When DHCP is enabled, it shows the automatically assigned IP address; when DHCP is disabled, it shows the manually specified IP address.

4. Subnet mask

The netmask of your printer. When DHCP is enabled, it shows the automatically assigned netmask; when DHCP is disabled, it shows the manually specified netmask.

5. Gateway

The gateway of your printer. When DHCP is enabled, it shows the automatically assigned gateway; when DHCP is disabled, it shows the manually specified gateway.

6. Mac address

The unique address assigned to your printer that connects to the internet.

7. DHCP

When DHCP is enabled, it assigns an IP address to your printer automatically.

8. DHCP Hostname

The name of a DHCP client.

9. Socket Port

The socket number of the printer.

10. SSID

Short for service set identifier. It is the name of a wireless local area network.

11. Mode

There are ad-hoc and infrastructure modes. Refer to the Print Tool Network type description from the Technical manual.

12. Country Code

The country or region.

13. Channel

The Wi-Fi channel.

14. Network Authentication

There are six modes. Refer to the Printer Tool Network authentication description from the Technical manual.

15. WEP

Refer to the description of the Printer Tool Wep in the technical manual.

PPLA

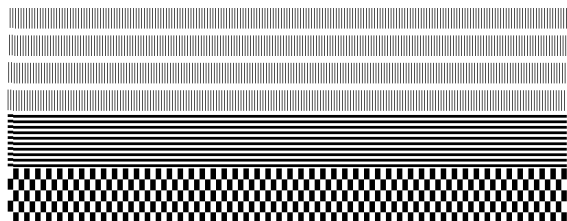

R8/E94/PC/PCA/PCB/LG

Courier Fonts:

ASD Smooth font (18 points) - 12
ASD Smooth font (14 points) - 123456789
ASD Smooth font (12 points) - 123456789 ABCa
ASD Smooth font (1 points) - 123456789 ABCabcXyz
ASD Smooth font (8 points) - 123456789 ABCabcXyz
ASD Smooth font (6 points) - 123456789 ABCabcXyz

123456789
This is internal font 7. 0CR-A ABCabc
THIS IS INTERNAL FONT
THIS IS INTERNAL FONT 5. 012345678
THIS IS INTERNAL FONT 4. 012345678
THIS IS INTERNAL FONT 3. 0123456789 ABCABC

This is internal font 2. 0123456789 ABCabcXyz
This is internal font 1. 0123456789 ABCabcXyz
This is internal font 0. 0123456789 ABCabcXyz
sso(0)<0.01mm>
rso(0)<0.01mm>
bv(329.9,320)<0.01u<P>
sv(246.100,145)<0.01u<P>
rv(302,250,52)<0.01u<P>
sm(0,0)<1+ 0-.0.01mm>
rm(0,0)<1+ 0-.0.01mm>
ot(0,0)<0.1dot,0.01mm>
CG ENABLED
USB SN: 000000000001
PRODUCT SN: 00000000001
LINK LOCAL : 0000:0000:0000:0000:
0000:0000:0000:0000
IPV6 ADDRESS: 0000:0000:0000:0000:
IPV6 TYPE: NONE
IPV6 MODE: MANUAL
SOCKET PORT: 9100
SOCKET COMM.: ENABLED
SNMP: ENABLED
DHCP HOST NAME:
DHCP CLIENT ID: FFFFFFFFFFFFFFFF
DHCP: ENABLED
MAC ADDRESS: 00-00-00-00-00-00
GATEWAY: 0.0.0.0
SUBNET MASK: 0.0.0.0
IP ADDRESS: 0.0.0.0
CUTTER/PEELER OFFSET: 0 <+-0.01mm>
PEELER DISABLED
CUTTER ENABLED
BACKFEED DISABLED
CALIBRATION MODE: INTELLI PRINT
MEDIA : NON-CONTINUOUS
STD CTRL CODES
CODE PAGE : PC-850
RS232: 9600,8,N,1P,XON/XOFF(SOFTWARE)
CUT COUNT:34
PRINT LENGTH: 12M
THERMAL TRANSFER
DARKNESS: 10
SPEED: 6 IPS
LAB LEN(TOP TO TOP): 79mm
PRINT WIDTH: 801 DOTS
MAX LABEL HEIGHT: 100 INCHES
RTC TIME: 6/13/16(12:22:44)
REF: 0221 SEE: 0098
SEE-THRU SENSOR
H. POSITION ADJUST.: 0000
NO. OF DL SOFT FONTS(HOST) : 0
NO. OF DL SOFT FONTS(RAM) : 0
NO. OF DL SOFT FONTS(FLASH) : 0
AVAILABLE FLASH : 8448K BYTES
FLASH TYPE : ON BOARD 16M BYTES
AVAILABLE RAM : 3676K BYTES
STANDARD RAM : 32M BYTES
iX4-250-V01.01.20170307 PPLA
LABEL PRINTER WITH FIRMWARE

PPLZ

LABEL PRINTER WITH FIRMWARE
iX4-250-V01.01 20170307 PPLZ
STANDARD RAM : 32M BYTES
AVAILABLE RAM : 3676K BYTES
FLASH TYPE : ON BOARD 16M BYTES
AVAILABLE FLASH : 8448K BYTES
NO. OF DL SOFT FONTS(FLASH) : 0
NO. OF DL SOFT FONTS(RAM) : 0
NO. OF DL SOFT FONTS(HOST) : 0
H. POSITION ADJUST.: 0000
SEE-THRU SENSOR
REF: 0221 SEE: 0098
RTC TIME: 6/13/16(12:25:11)
MAX LABEL HEIGHT: 100 INCHES
PRINT WIDTH: 801 DOTS
LAB LEN(TOP TO TOP): 79mm
SPEED: 6 IPS
ABS. DARKNESS: 16
TRIM. DARKNESS: 0
THERMAL TRANSFER
PRINT LENGTH: 12M
CUT COUNT:34
RS232: 9600, 8, N, 1P, XON/XOFF
CARET CONTROL CHAR : <^> 5EH
DELIMITER CONTROL CHAR : <,> 2CH
TILDE CONTROL CHAR : <~> 7EH
CODE PAGE : USA1
MEDIA : NON-CONTINUOUS
CALIBRATION MODE: INTELLI PRINT
REPRINT AFTER ERROR : ENABLED
BACKFEED DISABLED
CUTTER ENABLED
PEELER DISABLED
CUTTER/PEELER OFFSET: 0 <+-0.01mm>
IP ADDRESS: 0.0.0.0
SUBNET MASK: 0.0.0.0
GATEWAY: 0.0.0.0
MAC ADDRESS: 00-00-00-00-00-00
DHCP: ENABLED
DHCP CLIENT ID: FFFFFFFFFFFFFFFF
FFFFFFFFFFFFFFF
DHCP HOST NAME:
SNMP: ENABLED
SOCKET COMM.: ENABLED
SOCKET PORT: 9100
IPV6 MODE: MANUAL
IPV6 TYPE: NONE
IPV6 ADDRESS: 0000:0000:0000:0000:
0000:0000:0000:0000
LINK LOCAL : 0000:0000:0000:0000:
0000:0000:0000:0000
PRODUCT SN: 00000000001
USB SN: 000000000001
CG ENABLED
ot(0,0)<0.1dot,0.01mm>
rm(0,0)<1+ 0-,0.01mm>
sm(0,0)<1+ 0-,0.01mm>
rv(302,250,52)<0.01u><P>
sv(246,100,145)<0.01u><P>
bv(329,9,320)<0.01u><P>
rso(0)<0.01mm>
sso(0)<0.01mm>
THIS IS FONT A. 0123ABCabc
THIS IS FONT B. 0123ABCABC
THIS IS FONT C. 0123ABCabc
THIS IS FONT D. 0123ABCabc
THIS IS FONT E. 0123ABCabc
THIS IS FONT F. 0123ABCabc
THIS IS FONT G.
THIS IS FONT H. 0123ABC
This Is Font CG Triumv Bd Condensed.

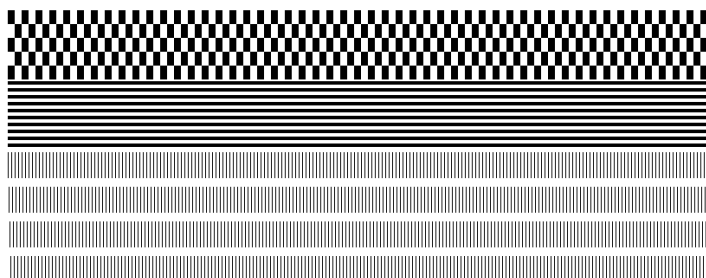

3.4 Resetting to Factory Default Settings

Be cautioned that this will reset all printer settings back to defaults; if possible, print the configuration label in advance before resetting. All settings stored in FLASH memory are retained even after turning off the printer. Printer mode without LCD can see indicators.

To reset the printer to factory default settings:

1. Turn off the printer.
2. Press and hold the **CANCEL** button and turn on the printer.
3. When “RESET ...” is displayed on the LCD and the READY indicator blinks, release the **CANCEL** button.
4. When “READY” is displayed on the LCD, the READY indicator stops blinking but remains illuminated.
5. The following information is now back to defaults:
 - Label parameters
 - Heat (Darkness)
 - Speed
 - Others for specific emulation

For more detail information, refer to CH 3.1.1 NO.26 [Load default](#)



Note:

Print length meter which indicates label length already printed cannot be reset.

3.5 Media sensing

The printer offers two types of media sensors: transmissive and reflective. Both sensor types detect specific media types and are installed together as a movable module.

3.5.1 Transmissive sensor

The transmissive sensor is used for detecting gaps across the entire width of the label.

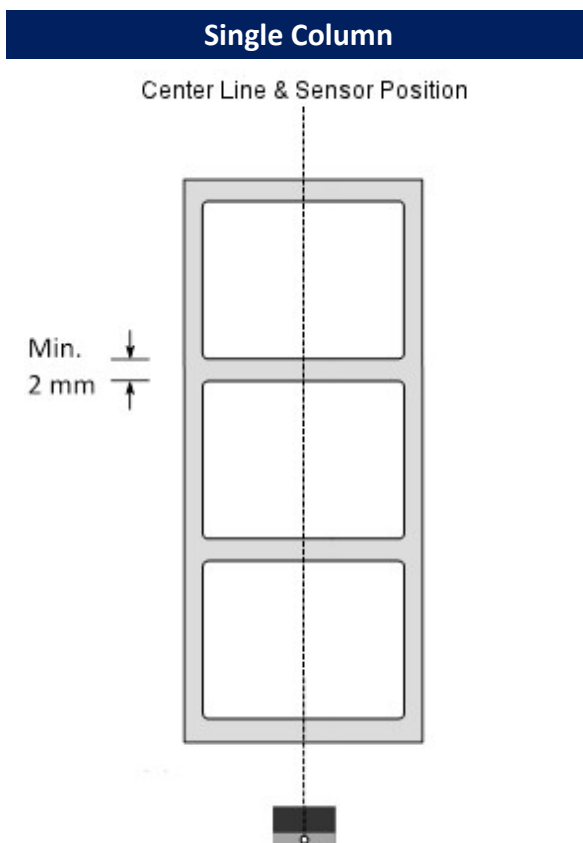

3.5.2 Reflective sensor

The reflective sensor detects gaps, notches and black marks.

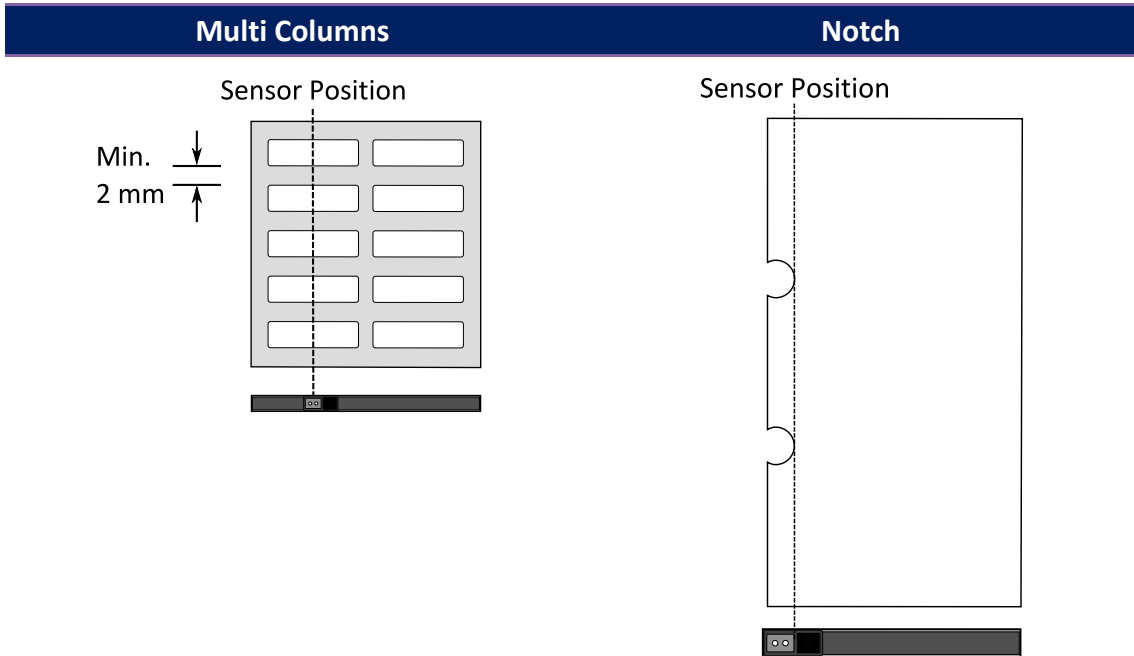

Black Mark

Flip the media so the black-mark side is facing down to align with the sensor.

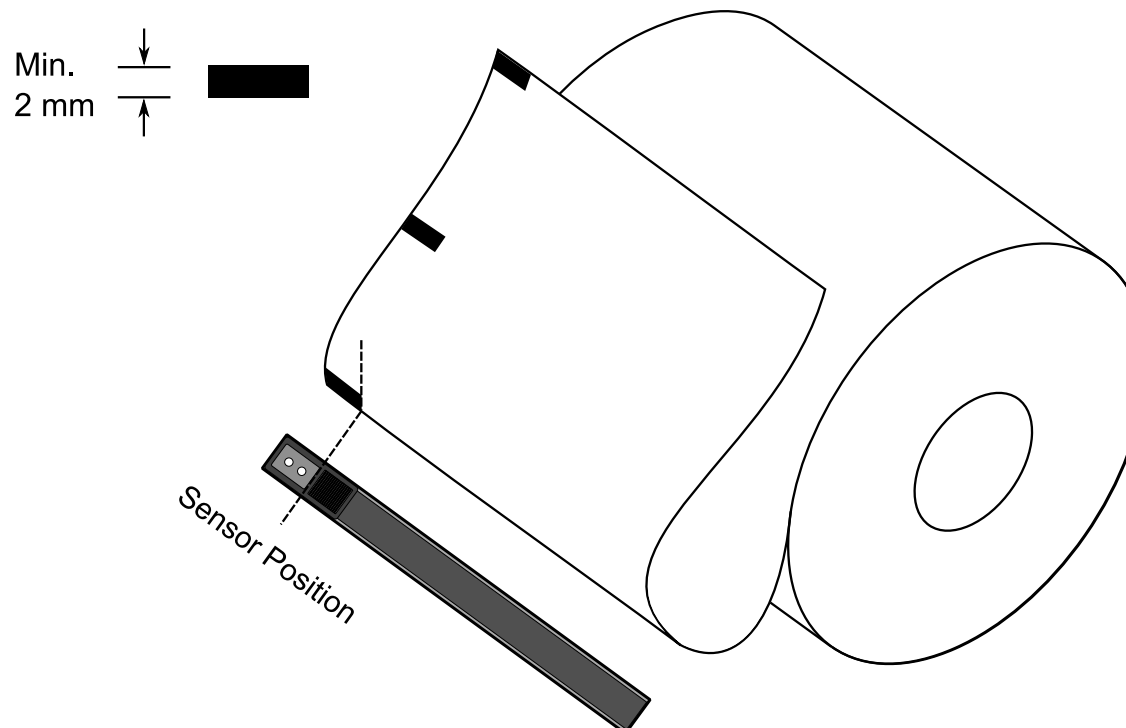

3.5.3 Adjust Position of Label Sensor

Function of the label sensor is to detect the gap, notch, or holes of labels, to help the printer for accurate print positions and label length. For labels with gaps, label sensor can be positioned wherever media locates. If labels with notches or holes are in use, pull in or out Paper Sensor Position Lever, to horizontally adjust position of label sensor

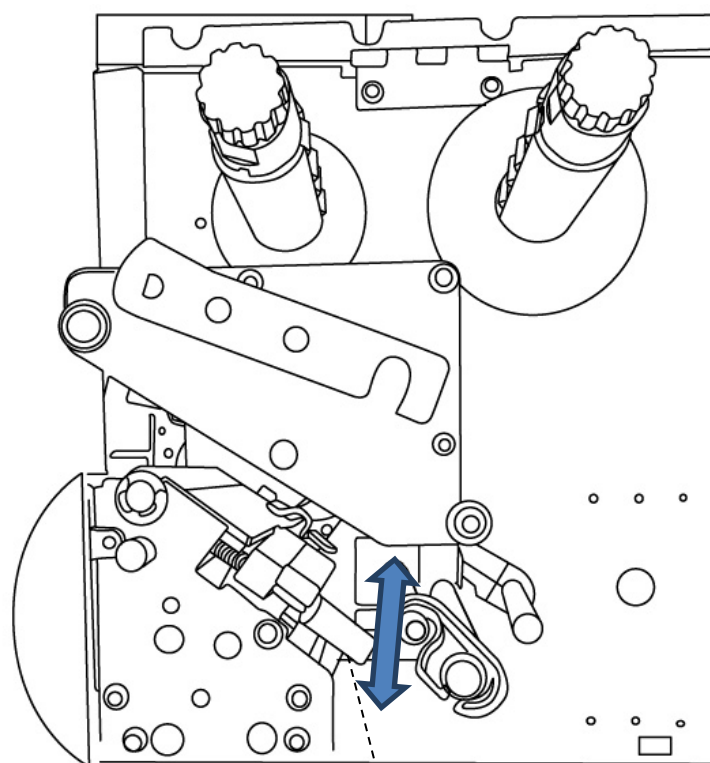

Paper Sensor Position Lever

- Make sure the Media sensor position mark locates right on notch or hole of labels. Check below.

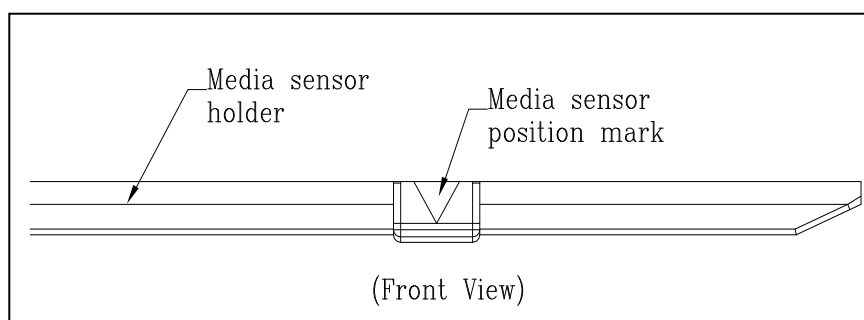

3.6 Communications

3.6.1 Interfaces and Requirements

This printer comes with USB type A and type B interface, a nine-pin Electronics Industries Association (EIA) RS-232 serial data interface, GPIO interface (Optional).

■ USB Interface Requirements

The Universal Serial Bus (USB) interface is compatible with your existing PC hardware. The USB's "plug and play" design makes installation easy. Multiple printers can share a single USB port/hub. The different usage of type A and B as below.

USB type A	USB Flash drive, USB keyboard or USB Scanner.
USB type B	PC to set printer.

■ Serial (RS-232) Port

The required cable must have a nine-pin "D" type male connector on one end, which is plugged into serial port located on the back of the printer. The other end of the cable connects to a serial port on the host computer. For technical and pin-out information, please refer to [RS-232C](#) in this manual.

■ General-purpose input/output (GPIO)

Pins depend on usage and the signal is user selectable. The function is diversity. For general-purpose, I/O signals programmed as inputs can cause CPU interrupted. For more information, contact local dealer.

■ Ethernet Module Status Indicators

The indicators with two different colors help users understand the status of Ethernet:

LED Status	Description	
Both Off	No Ethernet link detected.	
Blinking	The printer waits for printer ready. It will take about few seconds to be ready.	
Orange (Yellow)	Duplex/COL LED	On: Full duplex Off: Half duplex Blinking: Collision occurs
Green	Link/Activity LED	On: link up Off: link down Blinking: activity

3.7 Driver installation

The bundled printer driver can be applied to all applications under Windows Vista/ Windows 7/ Windows 8/ Windows 10, supporting 32-bit/ 64-bit operation systems. With this driver you can operate any popular Windows software applications including Argox Bartender UL label editing software or MS Word, etc., to print to this printer.

Drivers can be downloaded from Argox website (<https://www.argo.com/>).

3.7.1 Installing a Plug and Play printer driver (for USB only)



Note:

We strongly recommend that you use the Seagull Driver Wizard instead of the Microsoft Windows Add Printer Wizard when installing and updating your Drivers by Seagull.

(Even though the "Add Printer Wizard" is from Microsoft, it too easily performs a number of tasks incorrectly when updating existing drivers. It also badly handles the situation where a printer driver is already in use by a Windows application.)

1. Turn off the printer. Plug the power cable into the power socket on the wall, and then connect the other end of the cable to printer's power socket. Connect the USB cable to the USB port on the printer and on the PC.
2. Turn on the printer. If the printer supports Plug-and-Play, and you have successfully connected it using a USB cable, then the Windows Add Hardware Wizard will automatically detect the printer and display a dialog that allows you to install a driver. Click Cancel and do not install the driver using this wizard.

3. Run the driver from Argox website. On the prompt, Windows Printer Driver, select "I accept..." and click "Next".

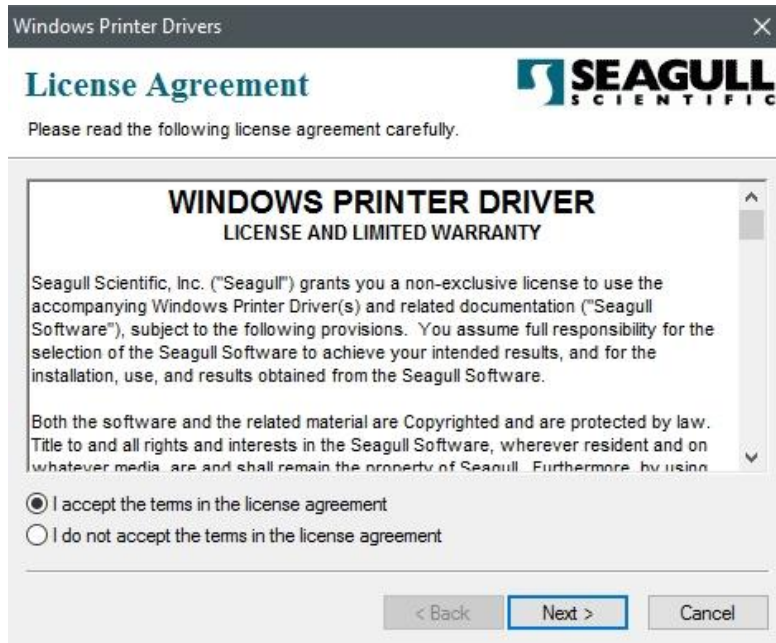

4. Assign the directory to keep Seagull driver, (for example: C:\Seagull) and click "Next".

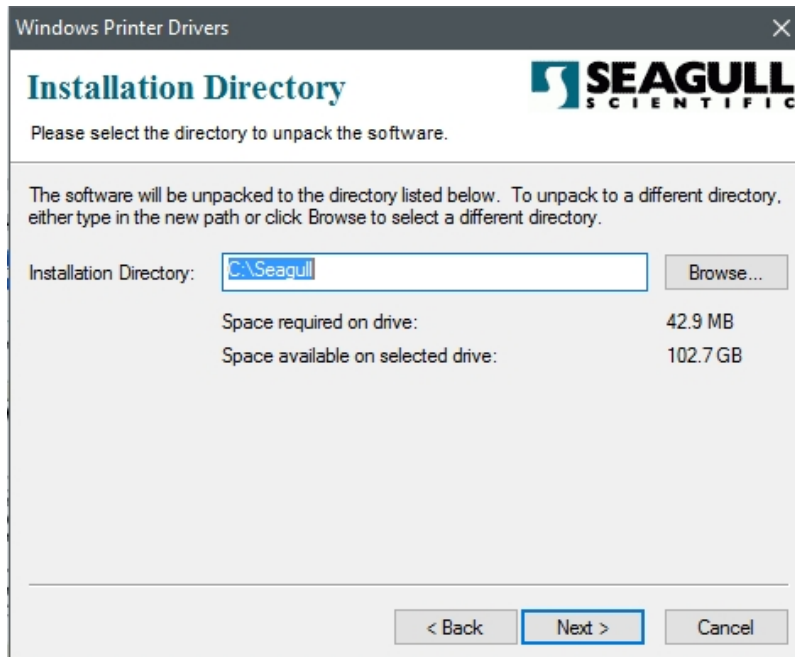

5. Click "Finish".

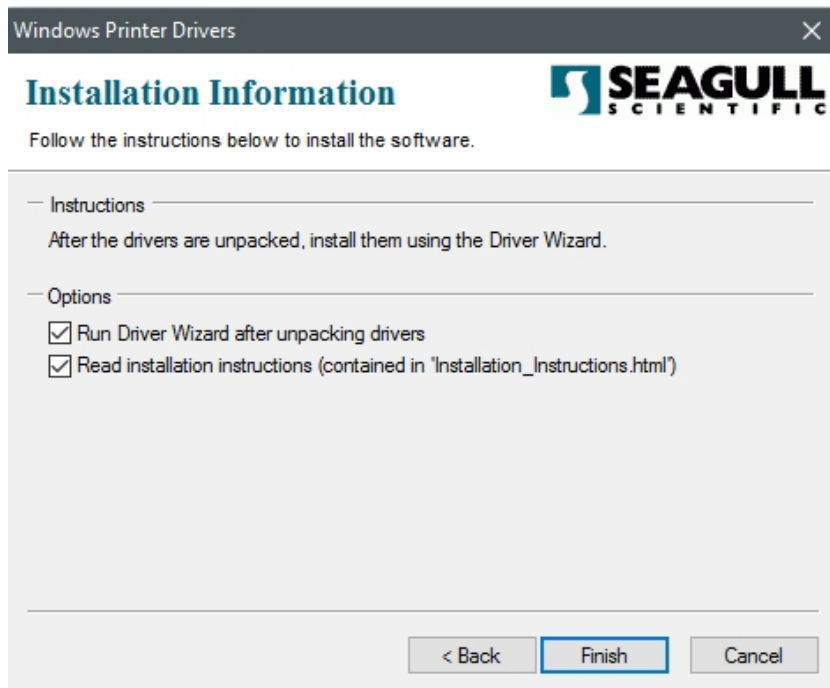

6. Select Install printer drivers and Click "Next"



7. On the Seagull Driver Wizard prompt, select the first radio button to “Install a driver for a Plug and Play printer” Then click “Next.”

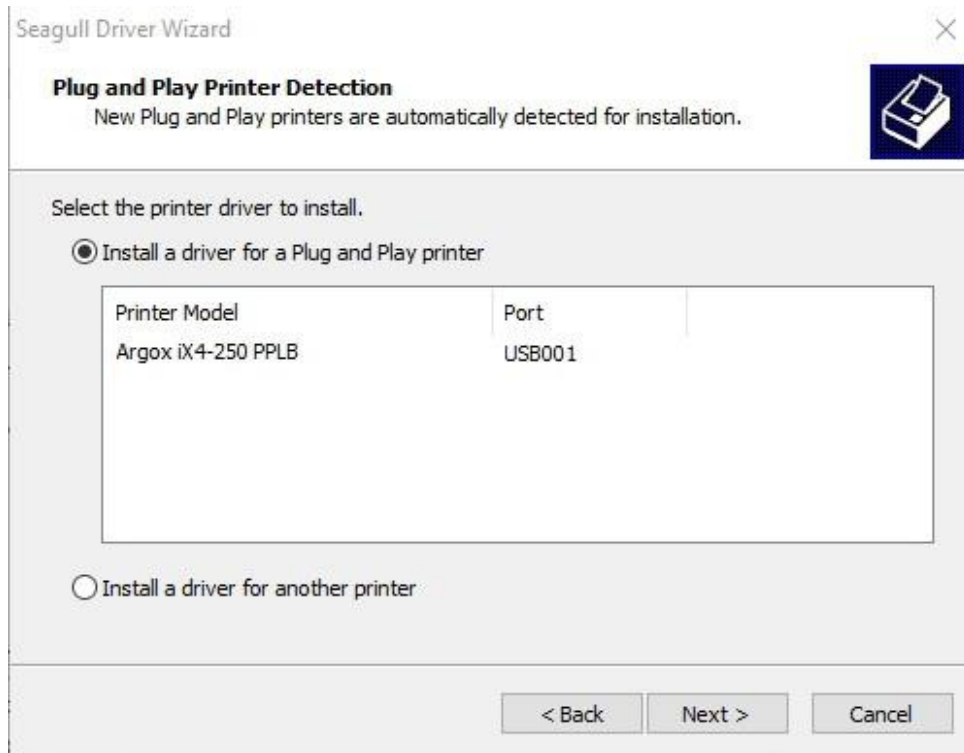

8. Enter Printer name (i.e. Argox iX4-250 PPLB) and select "do not share this printer", and click "Next"

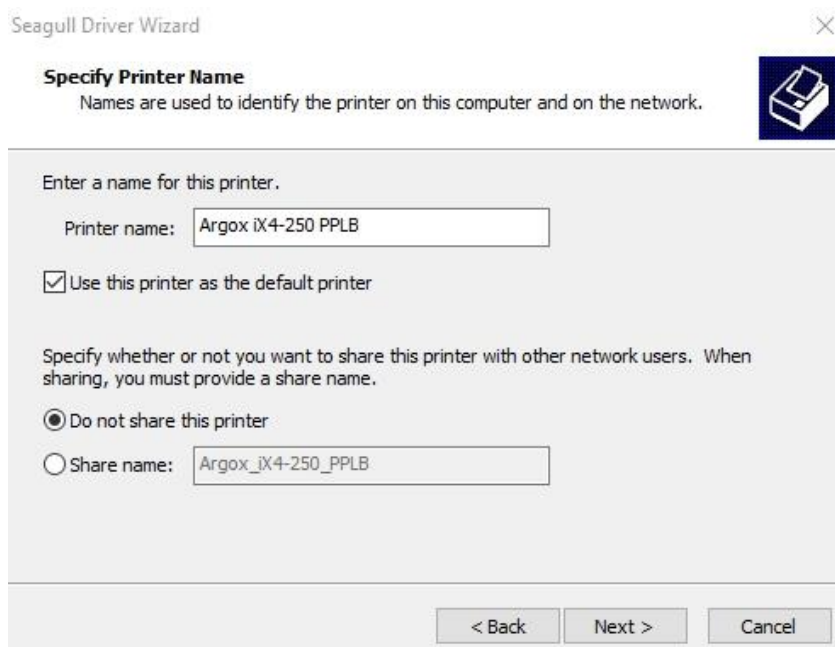

9. Check all the data on the showing screen, if it is correct, click "Finish".

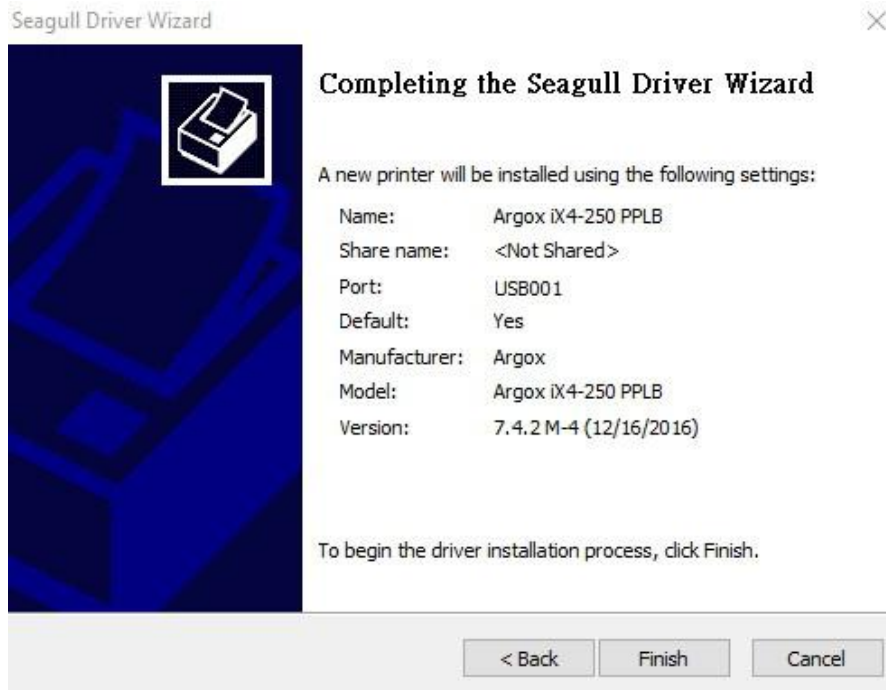

10. After the related files have been copied to your system, click "Finish".

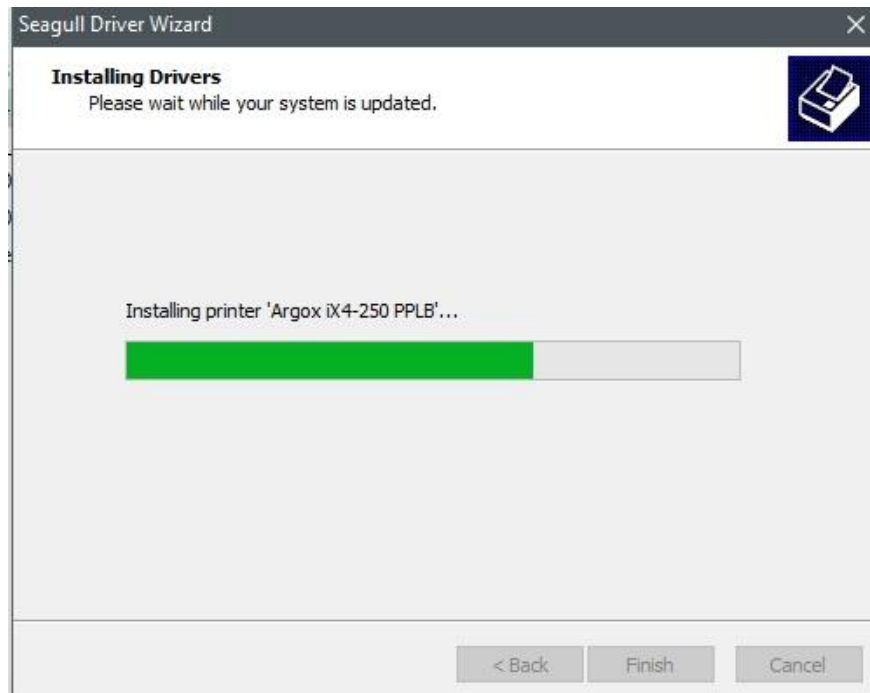

11. After driver installation is complete, click "Close". The driver should now be installed.

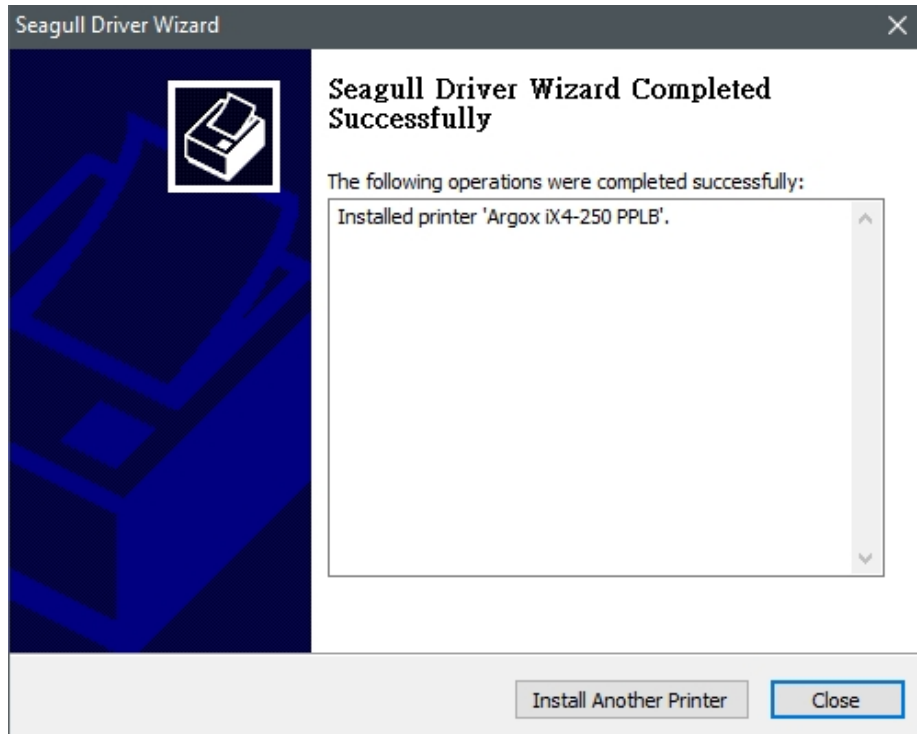

3.7.2 Installing a Printer Driver (for other interfaces except USB)

1. Turn off the printer. Plug the power cable into the power socket on the wall, and then connect the other end of the cable to printer's power socket. Connect the Serial cable or Ethernet cable to the proper port on the printer and on your computer.
2. Run the driver from Argox website. On the prompt, Windows Printer Driver, select "I accept..." and click "Next".



3. Assign the directory to keep Seagull driver, (for example: C:\Seagull) and click "Next".

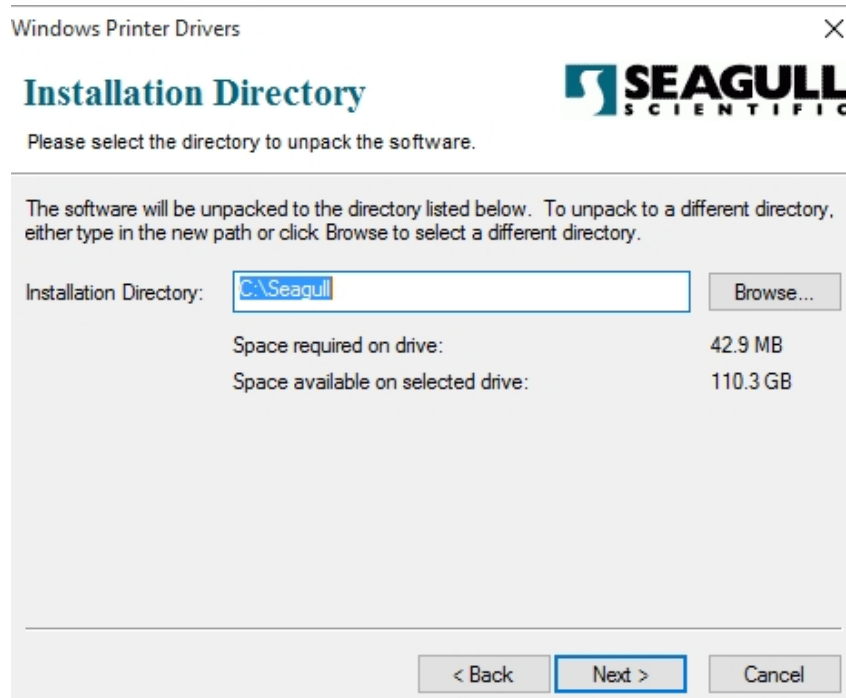

4. Click "Finish".

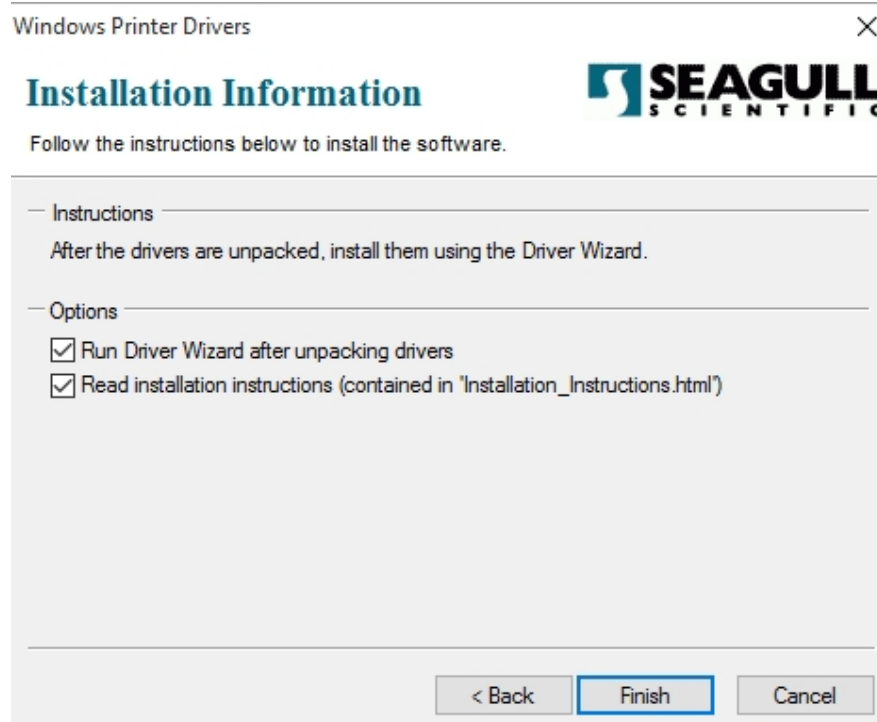

5. Select Install printer drivers and Click "Next"



6. Make sure printer is connected to PC, select "Other" and click "Next":

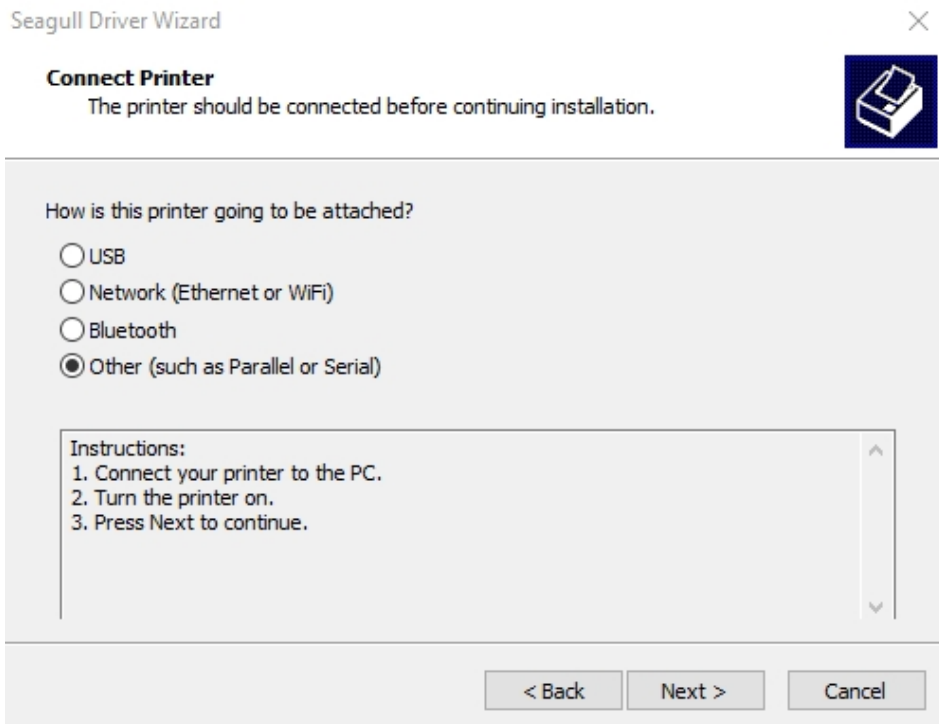

7. Select model & emulation - the following examples are based on model iX4-250

PPLB:

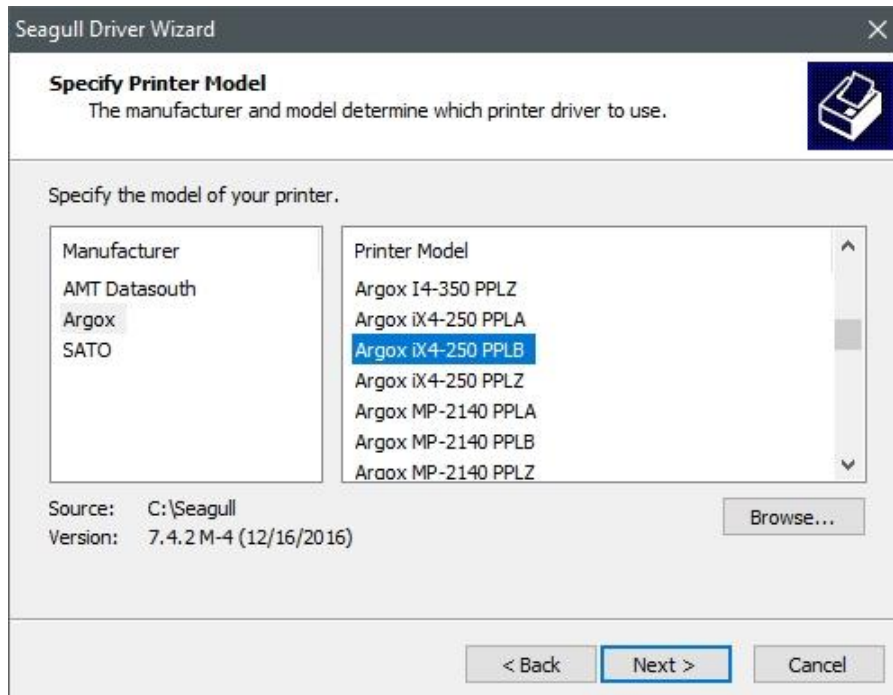

8. Select the port of the printer and click "Next".

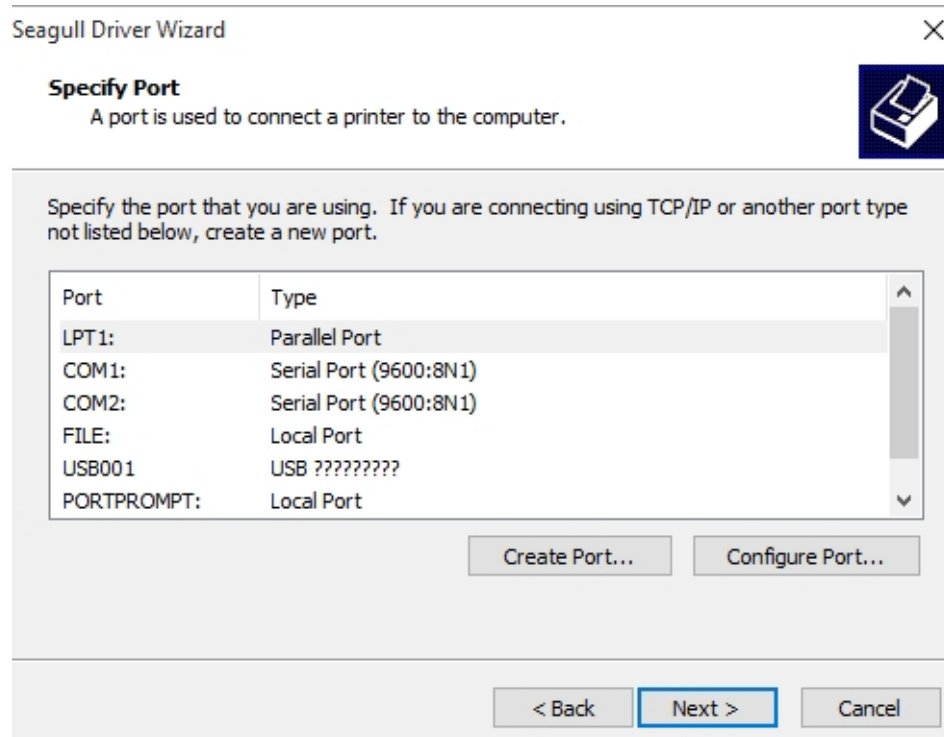

9. Enter Printer name (i.e. Argox iX4-250 PPLB) and select "do not share this printer", and click "Next".

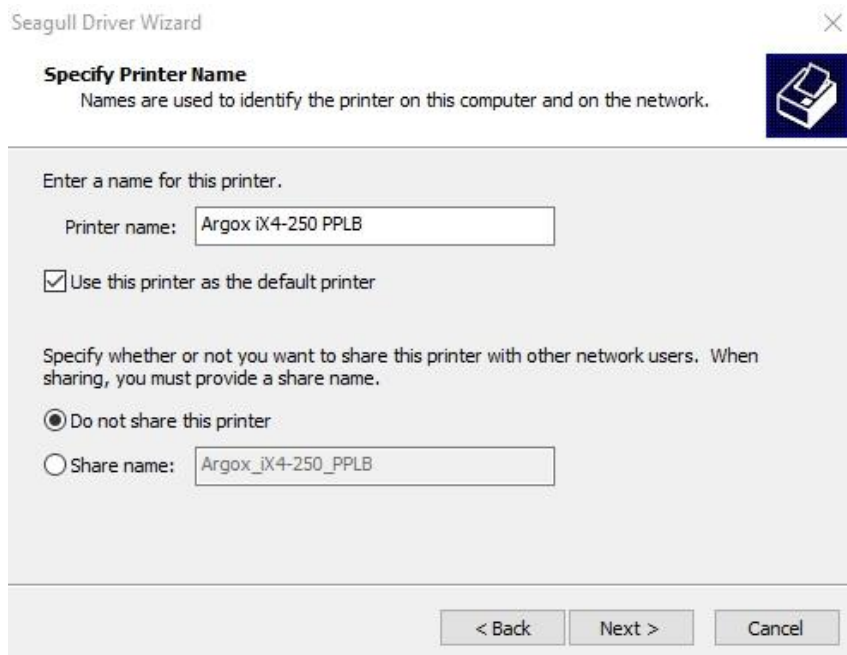

10. Check all the data on the showing screen, if it is correct, click "Finish".

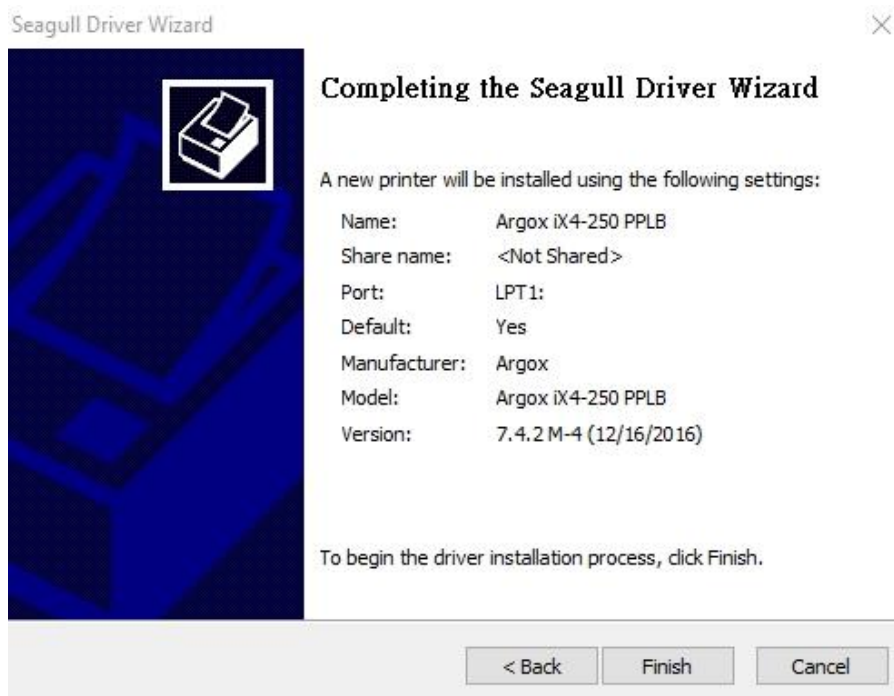

11. After the related files have been copied to your system, click "Finish".

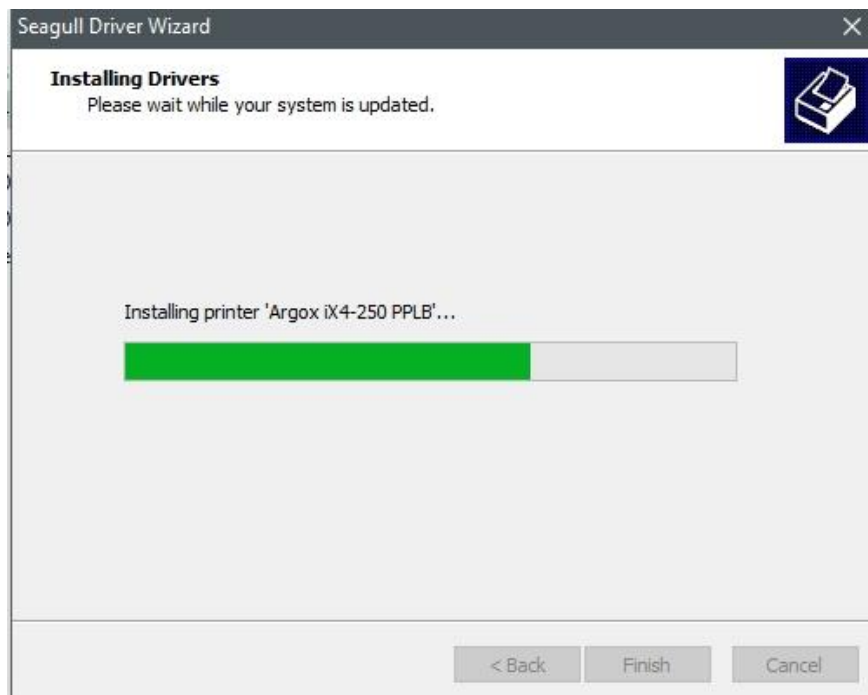

12. After driver installation is complete, click "Close". The driver should now be installed.

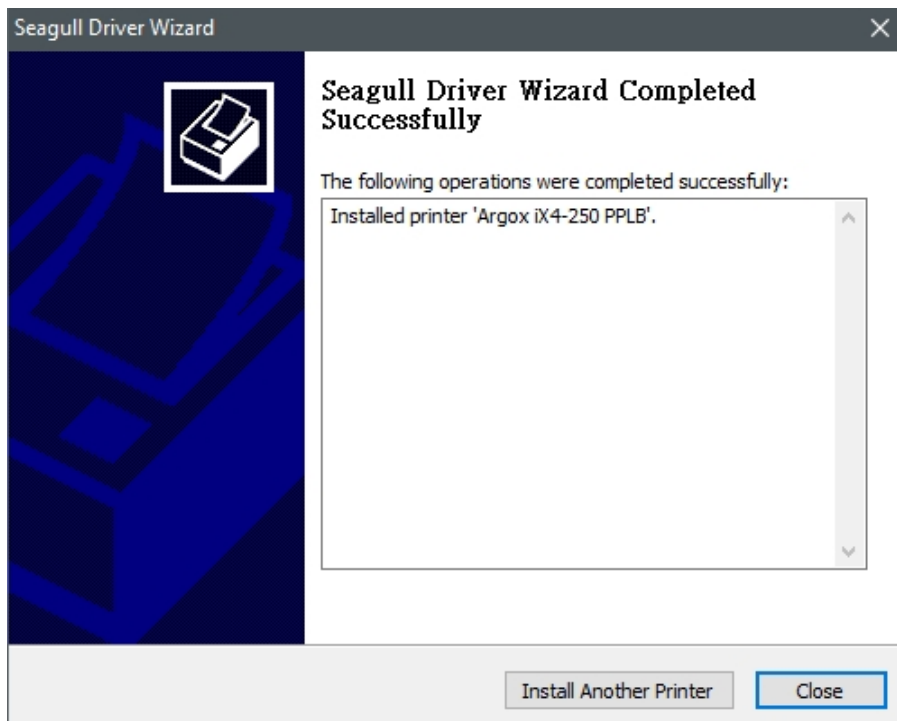

4 Configuration on Web Setting Tool

Before doing settings for your printer, be sure that you have a LAN cable. The cable is connected to the LAN connector of your printer. The LAN connector is an 8-PIN RJ45 type modular connector. Please use the LAN cable of CAT 5 of a proper length to connect the LAN connector on the printer to a LAN hub as appropriate.

The default static IP address of the printer is 0.0.0.0 and the default listen port is 9100. For the first time, to configure your printer through the web setting tool, you must still follow the step-by-step instructions below.

4.1 Attaching the power cord

1. Make sure the printer power switch is set to the **OFF** position.
2. Insert the power supply's connector into the printer power jack.
3. Insert the AC power cord into the power supply.

Important: Use only the power supply listed in the user instructions.

4. Plug the other end of the AC power cord into the wall socket.



Do not plug the AC power cord with wet hands or operate the printer and the power supply in an area where they may get wet. Serious injury may result from these actions!

4.2 Connecting the printer to a LAN hub

Use a LAN cable of CAT 5 of a proper length to connect the LAN connector on the printer to a LAN hub to which your desktop or laptop PC as a host terminal is also connected.

4.3 Getting the IP address of the printer

You can have the printer run a self test to print a configuration label, which helps you get the IP address of your printer connected to the LAN hub.

1. Turn off the printer.
2. Press and hold the **FEED** button, and turn on the printer.
3. Both status lights glow solid amber for a few seconds. Next, they turn to green shortly, and then turn to other colors. When LED 2 turns to green and LED 1 turns to amber, release the **FEED** button.
4. Press the **FEED** button to print a configuration label.
5. Get the IP address of the printer from the printed configuration label.

4.4 Logging in to the web setting tool

The Web Setting Tool is a build-in setting tool in firmware for ARGOX serial printers. User can connect to the supported ARGOX serial printers with browsers to get or set the printer settings, update firmware, download font, etc.

After obtaining the IP address of the LAN printer from the printed configuration label, you can connect to the printer with the supported browsers by input the IP address of the printer, *for example, 192.168.6.185*, in the URL field and connect to it.

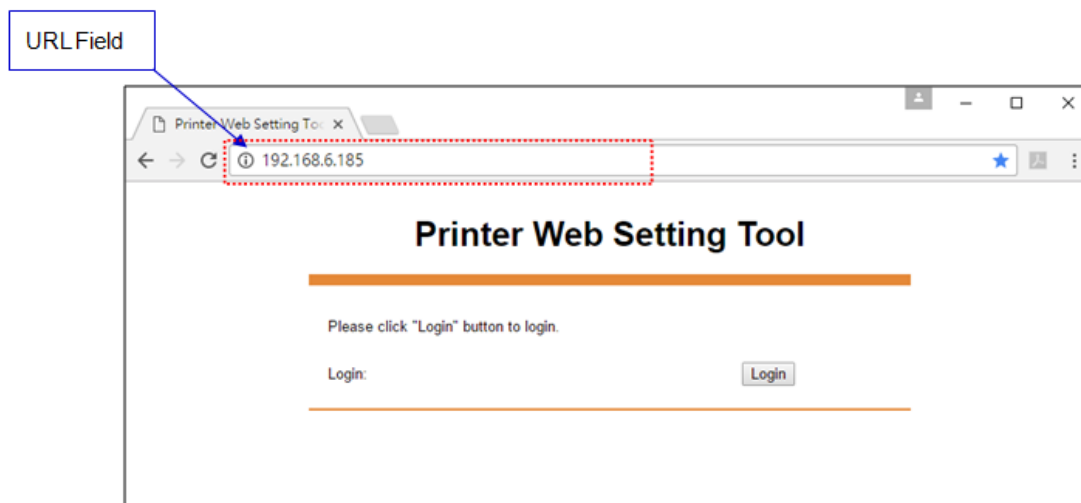

When the connection is successful, the Login page will be displayed. Input the user name and password to log in to the web setting tool. The default user name and the default password are given below:

Default user name: admin

Default password: admin

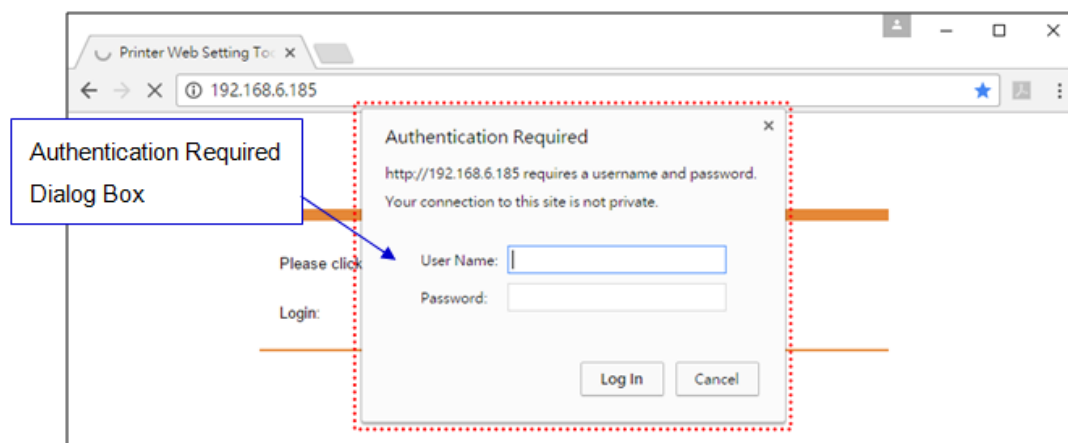

The default password can be changed in the "Device Setting \ Change Login Password" webpage.

This web setting tool can be used to manage multiple label printers in the same local area network segment under the Windows operating system as long as there is no conflicting IP address in the network. You can also check each of the MAC addresses listed in this tool against the MAC address label you can find on each of the printers.

The label printer that is connected through TCP/IP in the way like a directly connected local printer can be used with a random PC connected in the same local area network segment. So, through the tool, all commands applicable to the LAN mode can work on the printer in the same way, as the printer must be configured upon the TCP/IP communication protocol with the IP address of the printer.

When doing settings through a tablet PC or Smart Phone for the printer working in infra mode, please set the same network segment of the host terminal to that of the printer, for example, 192.168.6.XXX (1~254). The Wi-Fi mode for the printer is infra mode that can be searched by the wireless device manager of the host terminal.

5 Maintenance

Vertical streaks in the printout usually indicate a dirty or faulty print head. (Refer to the following examples.) Clean the print head. If the problem persists, replace the print head.

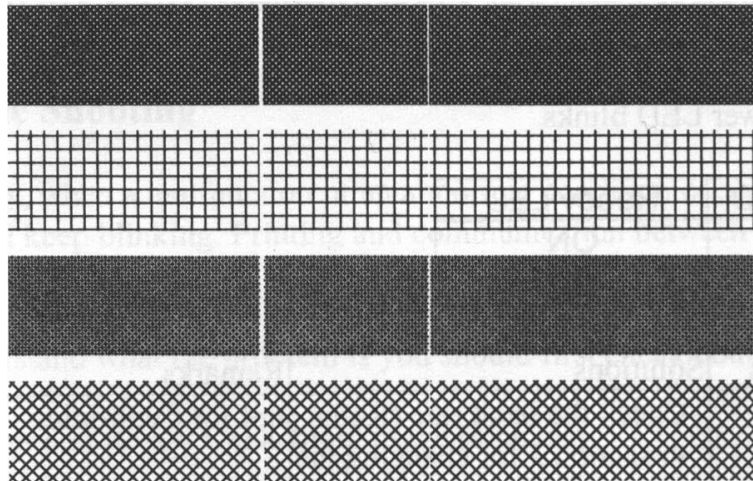

For unstable ribbon roll rotation, check the label path and make sure the head latch is securely closed.

Poor printout quality:

- The ribbon may not match the media in use.
- Adjust the Darkness (heat temperature).
- Slow down the print speed.
- Refer to the following and clean the related spare parts.

5.1 Cleaning

To maintain print quality and prolong the printer's life, you need to perform some routine maintenance. Daily maintenance should be done for high volume printing, and weekly for low volume printing.



Warning Always turn off the printer before cleaning.

5.1.1 Printhead

It is essential to keep printhead clean if you want the best print quality. We strongly recommend that you clean the printhead when you load a new media roll. If the printer is operated in critical environment, or the print quality declines, you need to clean the printhead more frequently.

Keep in mind these things before you clean:

- Keep the water away in case of corrosion on heating elements.
- If you just finish printing, wait until the printhead cools down.
- Do not touch the printhead with bare hands or hard objects.

Cleaning steps:

1. Moisten a soft cloth or a cotton swab with ethyl alcohol.
2. Gently wipe the printhead in one direction. That is, wipe it only from left to right or vice versa. Do not wipe back-and-forth, in case dust or dirt attaches to the printhead again.



Note Printhead warranty becomes void if printhead's serial number is removed, altered, defected, or made illegible, under every circumstance.

5.1.2 Platen Roller

The platen roller is also important for print quality. A dirty platen roller may damage the printhead. If adhesive, dirt, or dust accumulates on it, clean it right away.

1. Moisten a soft cloth with absolute ethyl alcohol.
2. Gently wipe the platen roller to remove the dust and adhesive.

5.2 Printer Adjustments

5.2.1 Printer Head Pressure Adjustment



Note The printer head pressure adjustment is available to XM4 series model which is with the serial number of 21C58061 or former. You can also contact your local service center or printer supplier for technical support.

Printing quality can be fine adjusted based on which area on the label the printing quality discrepancy is located. There are two ways to enhancement pressure. Spring pressure pad can be quickly adjusted in three levels can for pressure numerous. A dial is provided to allow the operator to slightly adjust the pressure.

**TPH Pressure Adjustable
(3 Levels)**

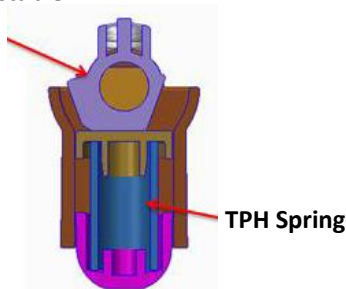

Spring pressure pad

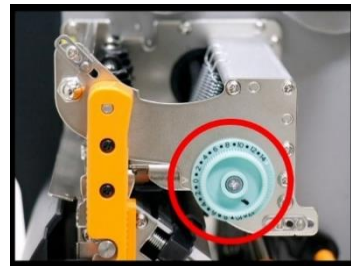

Scale dial

Adjust Spring pressure pad

Step.1 Please use either tool to switch the pressure level.

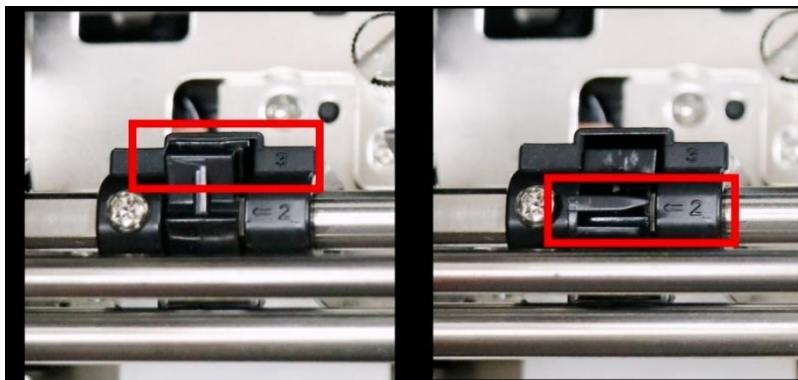

Step.2 Move the pad in one of the 3 positions. Among Position 1, Position 2 and Position 3, Position 3 is the thickest. If you want more pressure, move pad to position 3.

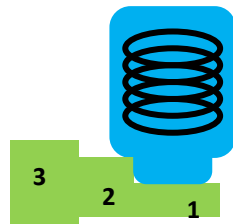

Switch to position 1 (- pressure)

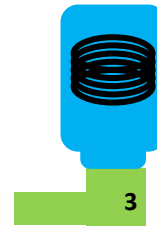

Switch to position 3 (+ pressure)

Adjust printer head rack

Step.1 Turn the dial in clockwise or counterclockwise direction.

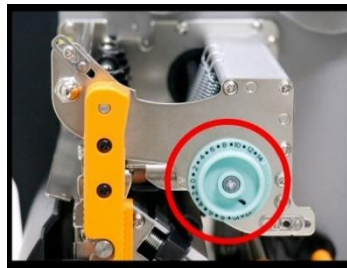

Step.2 Turn printer head rack clockwise to increase pressure or counterclockwise to decrease pressure.

Clockwise (+ pressure)



Counter-clockwise (- pressure)



Repeat the same process until the printing quality is well balanced on both ends of the label. Once the desired quality has been reached, please make note on the new setting of **Adjust Spring pressure pad, printer head rack position** and the type number of ribbon used in this printing task for future reference.



Note To print small labels, such as 1-2 inch labels, please adjust the pressure range of the print head.

5.2.2 Ribbon Tension Adjustment

Both ribbon supply spindle and ribbon pickup spindle are equipped with control knobs to adjust ribbon tension. The control knobs can rotate to both directions.

If the ribbon is wrinkled at ribbon supply, rotate clockwise control knob of ribbon supply, to increase ribbon tension at ribbon supply and further improve ribbon wrinkle.

- Rotate control knob clockwise to increase ribbon tension.

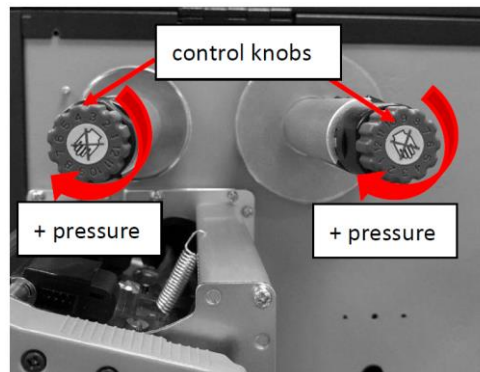

Too much tension at ribbon supply may result in ribbon not moving smoothly. Once it happens, rotate counterclockwise control knob of ribbon supply, to reduce ribbon tension to balance the tension.

- Rotate control knob counterclockwise to reduce ribbon tension.

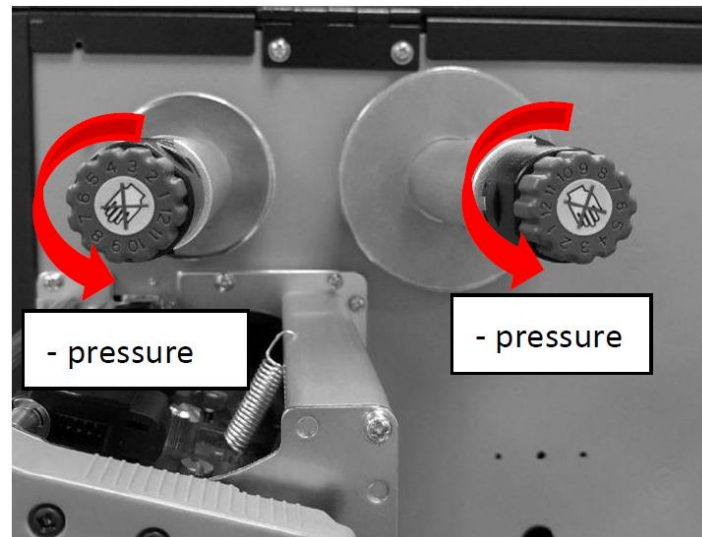

[Remark]:

The ribbon shaft has its user-friendly feature to allow users to adjust the tension of ribbon shaft by rotating the knob. User can reset to factory default tension by adjusting the ribbon shaft while the black line was aligned to the marked arrows. The default setting when shipped from Argox factory is shown as Figure 2 – the two arrows are in line with the black line.



Note If the ribbon is wrinkled at ribbon pickup, rotate counter-clockwise control knob of ribbon pickup, to decrease ribbon tension at ribbon pickup and further improve ribbon wrinkle. If the tension is too little at ribbon pickup, ribbon will not move smoothly, and needs control knob to rotate clockwise to increase tension.

5.2.3 Printing Wrinkle Adjustment

During printing, ribbon may wrinkle and cause abnormal printing quality. The following describes how to solve ribbon wrinkle accordingly.



Once the printouts as above appear, the possible cause may be the unequal positions of Ribbon Bracket, which needs to be adjusted properly to make its heights equally the same at both sides. Steps to adjust are as below:

1. Loose the screws at both sides and rotate counterclockwise:

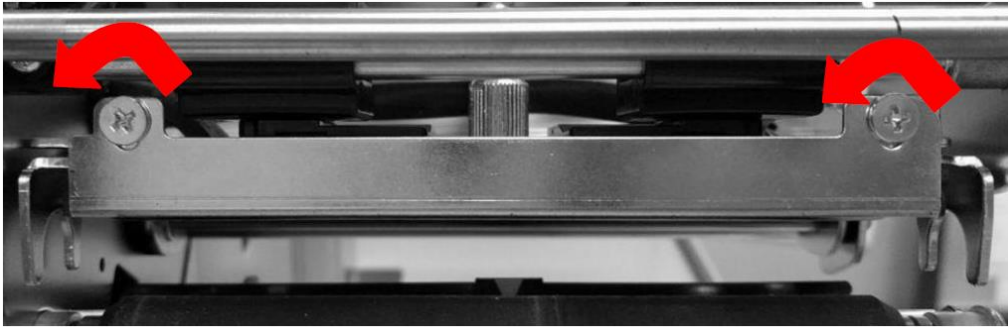

2. Make sure the Ribbon Bracket is at its **lowest** position first; then tight up the screws by rotating clockwise.

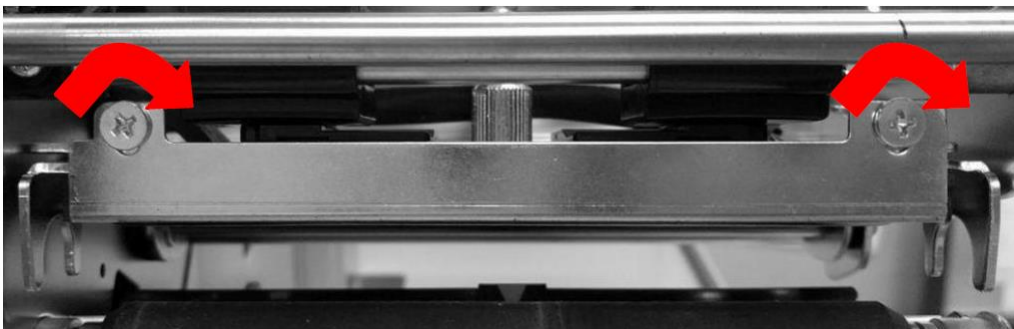

3. Alternatively, please reduce the occurrence of ribbon wrinkles through the ribbon wrinkle adjustment mechanism on both ends.

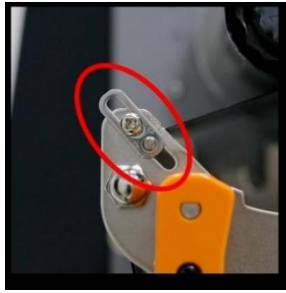

For Ribbon Rewind



For Ribbon Supply

4. Also alternatively, if you need to print smaller media, you can use the latch for the TPH of the printer to secure the small-sized media to prevent printing wrinkles during printing. You can loosen and remove the screw on the right side, move the right cam to the left, and then lock it back using the screw you just removed.



5. Print a test page to check print quality. If the quality is improved, stop the adjustment; if not, continue with next step.
6. If the test print appears as below, remain the screw at the right of Ribbon Bracket fixed, then loose the screw at the left, and gradually fine-tune upward, until the print quality gets improved.



If the test print appears as Figure B, remain the screw at the left of Ribbon Bracket fixed, and then loose the screw at the right, and gradually fine-tune upward, until the print quality gets improved.



5.2.4 Small-size Media Offset Adjustment

To print on small media sizes, place the media against the media guide, as shown in the red circle below, to prevent the media from snaking or shifting.

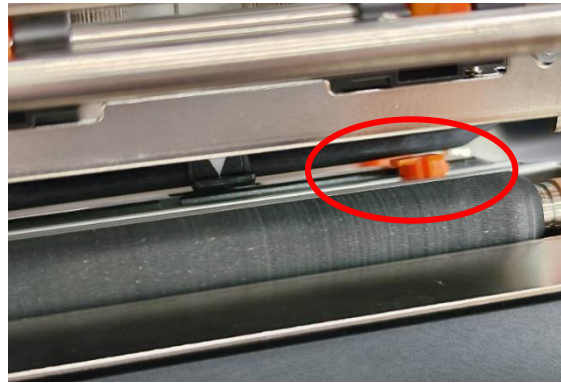

5.3 RTC Battery Replacement

- 6 RTC stands for Real Time Clock. It is a battery-powered clock that keeps track of the current date and time. If your printer has a built-in RTC timer, you'll find the RTC timer battery on the main circuit board. The RTC timer battery keeps the RTC timer running even when the printer is turned off. When the battery is low or dead, you will need to replace it with a new one.

To replace the RTC timer battery:

- 1 Turn off the printer and open the left side panel of the printer.
- 2 Locate the battery next to the main board (attached to the casing).
- 3 Disconnect the old button battery's power connector from the BT1 slot on the main board, and then remove the button battery from the casing.
- 4 Attach one side of the new button battery (with tape) to the casing near the main board, and then insert the battery's power connector into the BT1 slot on the main board.
- 5 Turn on the printer.

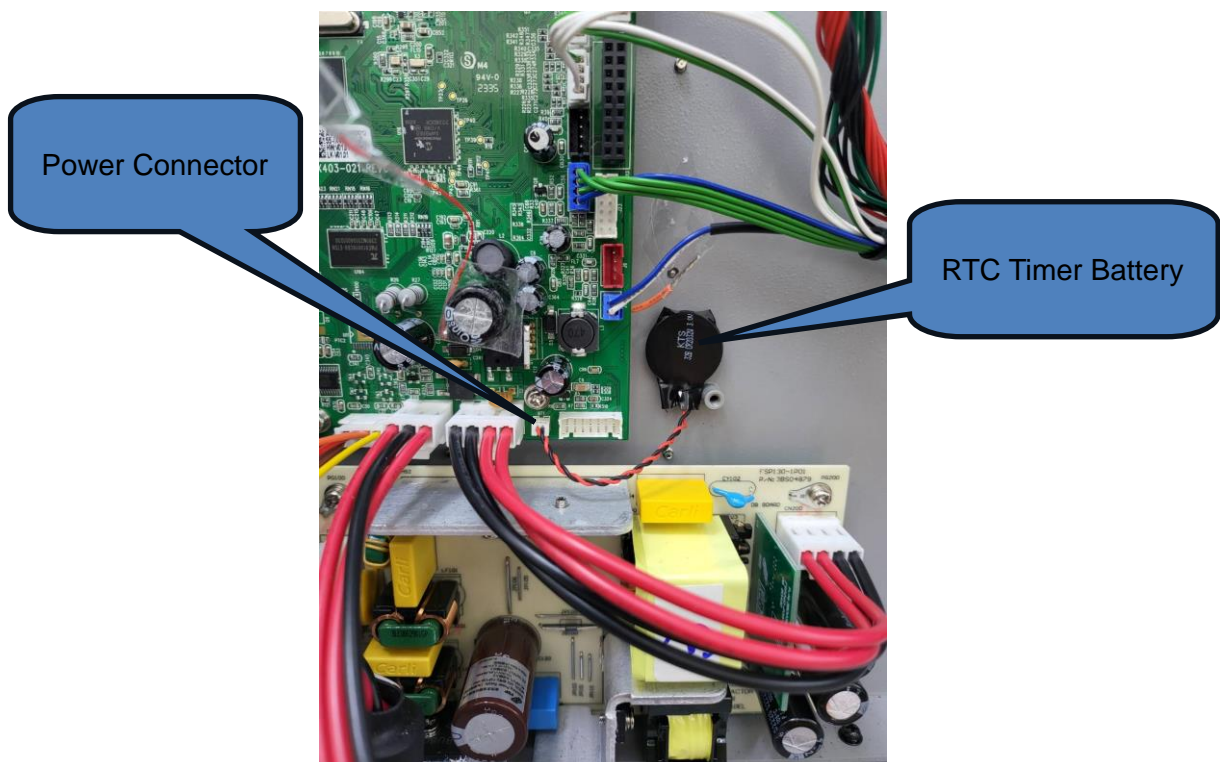

CAUTION:

Risk of explosion if battery is replaced by an incorrect type. Dispose of used batteries according to the instructions.

7 Troubleshooting

This chapter provides the information about printer problems and solutions.

7.1 Printer issues

The printer won't turn on

- Did you attach the AC power cord?
- Check the power connection from the wall socket to the printer. Test the power cord and the socket with other electrical devices.
- Disconnect the printer from the wall socket, and connect it again.

The printer turns itself off

- Turn on the printer again.
- If the printer keeps turning itself off, check the socket and make sure it has enough power for the printer.

The printer does not feed the media out

- The media is not loaded correctly. See Section 2.3, "[Loading Media](#)" to reload the media.
- If there is a paper jam, clear it.

7.2 Media issues



The media is out

- Load a new media roll.

The paper is jammed

- Open the printer and clear the jammed paper.
- Make sure the paper is held properly by the **Media Guides**.

The printing position is not correct

- Did you use the correct media type for printing?
- The media is not loaded correctly. See Section 2.3, "[Loading Media](#)" to reload the media.
- The media sensor needs to be calibrated. See Section 3.2, "[Printing Media Calibration & Configuration](#)" to calibrate the sensor.
- The media sensor is dirty. Clean the media sensor.

Nothing is printed

- The media is not loaded correctly. See Section 2.3, "[Loading Media](#)" to reload the media.
- The print data might not be sent successfully. Make sure the interface is set correctly in the printer driver, and send the print data again.
- Make sure the media and ribbon are both matched.

The print quality is poor

- The printhead is dirty. Clean the printhead.
- The platen roller is dirty. Clean the platen roller.
- Adjust the print darkness, or lower the print speed.
- The media is incompatible for the printer. Use appropriate media roll instead.

7.3 Ribbon issues

The ribbon is out

- Load a new ribbon roll.

The ribbon is broken

- Check the print darkness and adjust it if it is too high, and take the following steps to fix the broken ribbon:
 1. Unload the ribbon supply roll and take-up roll from the printer.
 2. Pull the ribbon from the supply roll so it overlaps the broken end of the take-up roll.
 3. Tape the overlapped parts together.
 4. Reload both rolls into the printer.

The ribbon is “printed out” with the media

- The ribbon is not loaded correctly. See Section 2.4, “[Loading Ribbon](#)” to reload the ribbon.
- The printhead temperature is too high. Reload the ribbon and print a configuration label to check the settings (See Section 3.2, “[Printing Media Calibration & Configuration](#)”). If the print darkness is very high, adjust it in printer preference, or reset your printer (see Section 3.3, “[Resetting to Factory Default Setting](#)”).

The ribbon is wrinkled

1. Make sure the ribbon is loaded correctly.
Rotate Thumb Wheel of Ribbon spindles to straighten the ribbon.

7.4 Other issues

There are broken lines in the printed label

- The printhead is dirty. Clean the printhead.

The printhead temperature is extremely high

- The printhead temperature is controlled by the printer. If it is extremely high, the printer will stop printing automatically, until the printhead is cool down. After that, the printer will resume printing automatically, if there is any unfinished print job.

The printhead is broken

- Contact your local dealer for assistance.

8 Specifications

This chapter provides specifications for the printer.

8.1 Printer

Model	iX4-200 Pro	iX4-240 Pro	iX4-250 Pro	iX4-350 Pro
Print method	Direct Thermal & Thermal Transfer			
Resolution	203 dpi (8 dots/mm)			300 dpi (12 dots/mm)
Operation Mode	Standard: Continuous mode, Tear-off mode Optional: Cutter mode, Dispenser (Peeler) mode			
Sensor	Media Reflective sensor x 1 (movable) & Media Transmissive sensor x 1 (movable) / Head open switch / Ribbon end sensor			
Operation interface	LED indicator x 3, Button x 3		LED indicator x 3, Button x 3, RTC battery, LCD display	
Battery for RTC	Type: CR2032, +3V, 225mAh			
Print Speed	2-6 ips (51~152 mm/s)		2-8 ips (51~203 mm/s)	2-6 ips (51~152 mm/s)
Print Length	Max 100"(2540 mm) Min 0.2"(5mm)			50"(1270mm)) 0.2"(5mm)
Print Width	4.13" (105 mm)			4.08" (103.7 mm)
Communication Interface	USB device, RS-232		Standard: Ethernet, dual USB hosts, USB device, RS-232 Option: Wi-Fi (IEEE 802.11 b/g/n), GPIO, Buzzer	
Programming Language	PPLA+PPLB		PPLA+PPLB+PPLZ	
Accessories	Guillotine: Full Cutter, Partial Cutter, Rotary Cutter, Dispenser (Peeler)			
Onboard Memory	128MB DRAM (32MB available for user) / 128MB Flash ROM (100MB available for user) USB storage up to 32 GB (FAT32 format only)			

Model	iX4-200 Pro	iX4-240 Pro	iX4-250 Pro	iX4-350 Pro
CPU Type	32 bit RISC microprocessor			
Software---Label editing	Windows Driver (Windows Vista/ Win 7/ Win 8/ Win 10), BarTender® from Seagull Scientific			
Software--- Utility	Printer Tool			
Agency Listing	CE, FCC, CB/LVD, cULus, ICES, Energy Star			



Note Print quality and speed is based on 15% print coverage.

8.2 Media & Ribbon

Properties	Description
Media Size	<p>Max. width:4.4" (112mm). Min. width: 1" (25.4 mm). Thickness:0.0025"~0.01" (0.0635mm~0.254mm) 8.26"(210mm) OD on a 3"(76mm) ID core. 7"(177.8mm) OD on a 1.5"(38mm) ID core. Min. width 2.3" (58mm)for partial cutter options. Min. length 1"(25.4mm)for cutter options.</p> <p>※ <i>If the printer is equipped with an internal media rewinder, the maximum outer diameter of the media roll that can be used is 7 inches. This specification ensures the media can be properly fed and rewound within the printer's design.</i></p>
Media Type	Roll-feed, die-cut, continuous, fan-fold, tags, ticket or plain paper or label.
Ribbon Size	<p>Width:1"~4"(25.4 mm~101.6 mm) Length: max 450m Wax, 450m Semi-Resin. Max OD 3.2" (81.3 mm). Core size ID 1"(25.4 mm).</p>
Ribbon Type	Wax, Wax/Resin, Resin (Ribbon wound ink-side out or ink-side in)

8.3 Electrical and operating environment

Properties	Description
Power Supply	Voltage: AC 100 V ~ 240 V ± 10 % (full range) Frequency: 50 Hz - 60 Hz ± 5 %
Temperature	Operating: 40°F~104°F (4°C~40°C) Storage: -4°F~122°F (-20°C~50°C)
Humidity	Operating: 25 %RH ~ 85 %RH (non-condensing) Storage: 10 %RH ~ 90 %RH (non-condensing)

8.4 Physical dimension

Dimension	Size and Weight
Size	W 250mm x H 263mm x D 418 mm
Weight	11 kg(24lbs)



Note The specifications may be changed at any time without prior notice. For more information about the new specifications, visit Argox website or contact your dealer.

8.5 Fonts, Barcodes, and Graphics Specification

The specifications of fonts, bar codes and graphics depends on the printer emulation. The emulations PPLA, PPLB, and PPLZ are printer programming languages, through which the host can communicate with your printer.

Printer Programming Language PPLA

Programming Language	PPLA
Internal fonts	9 fonts with different point size 6 fonts with ASD smooth font. Courier font with different symbol sets.
Symbol sets (Code pages)	Courier font symbol set: Roman-8, ECMA-94, PC, PC-A, PC-B, Legal, and PC437 (Greek), Russian.
Soft fonts	Downloadable soft fonts by Print Tool
Font size	1x1 to 24x24 times
Character rotation	0, 90, 180, 270 degree, 4 direction rotation
Graphics	PCX, BMP, IMG, GDI and HEX format files
1D Barcodes	Code 39, UPC-A, UPC-E, Code 128 subset A/B/C, EAN-13, EAN-8, HBIC, Codabar, Plessey, UPC2, UPC5, Code 93, Postnet, UCC/EAN-128, UCC/EAN-128 K-MART, UCC/EAN-128 Random weight, Telepen, FIM, Interleaved 2 of 5 (Standard/with modulo 10 checksum/ with human readable check digit/ with modulo 10 checksum & shipping bearer bars) , GS1 Data bar (RSS)
2D Barcodes	MaxiCode, PDF417, Data Matrix (ECC 200 only) , QR code, Composite Codes, Aztec

Printer Programming Language PPLB

Programming Language	PPLB
Internal fonts	5 fonts with different point size
Symbol sets (Code pages)	8 bits code page : 437, 850, 852, 860, 863, 865, 857, 861, 862, 855, 866, 737, 851, 869, 1252, 1250, 1251, 1253, 1254, 1255 7 bits code page: USA, BRITISH, GERMAN, FRENCH, DANISH, ITALIAN, SPANISH, SWEDISH and SWISS
Soft fonts	Downloadable soft fonts by Print Tool
Font size	1x1 to 24x24 times
Character rotation	0, 90, 180, 270 degree, 4 direction rotation
Graphics	PCX , Binary Raster, BMP and GDI
1D Barcodes	Code 39, UPC-A, UPC-E, Matrix 2 of 5, UPC-Interleaved 2 of 5, Code 39 with check sum digit , Code 93, EAN-13, EAN-8 (Standard, 2 /5digit add-on) , Codabar, Postnet, Code128 subset A/B/C, Code 128 UCC (shipping container code) , Code 128 auto, UCC/EAN code 128 (GS1-128) , Interleave 2 of 5, Interleaved 2 of 5 with check sum, Interleaved 2 of 5 with human readable check digit, German Postcode, Matrix 2 of 5, UPC Interleaved 2 of 5, EAN-13 2/5 digit add-on, UPCA 2/5 digit add-on, UPCE 2/5 digit add-on, GS1 Data bar (RSS)
2D Barcodes	MaxiCode, PDF417, Data Matrix (ECC 200 only) , QR code, Composite Codes, Aztec

Printer Programming Language PPLZ

Programming Language	PPLZ
Internal fonts	8 (A~H) fonts with different point size. 8 AGFA fonts: 7 (P~V) fonts with fixed different point size (not scalable). 1 (O) font with scaling point size.
Symbol sets (Code pages)	USA1, USA2, UK, HOLLAND, DENMARK/NORWAY, SWEDEN/FINLAND, GERMAN, FRANCE1, FRANCE2, ITALY, SPAIN, MISC, JAPAN, IBM850, Multibyte Asian Encodings, UTF-8, UTF-16 Big-Endian, UTF-16 Little-Endian, Code page 1250, 1251, ,1252, 1253, 1254
Soft fonts	Downloadable soft fonts by Print Tool
Font size	1x1 to 10x10
Character rotation	0, 90, 180, 270 degree, 4 direction rotation
Graphics	GRF, Hex and GDI
1D Barcodes	Code39, UPC-A, UPC-E, Postnet, Code128 subset A/B/C, Interleave 2 of 5, Interleaved 2 of 5 with check sum, Interleaved 2 of 5 with human readable check digit, Code 93, Code 39 with check sum digit, MSI, EAN-8, Codabar, Code 11, EAN-13, Plessey, GS1 Data bar (RSS) , Industrial 2 of 5, Standard 2 of 5, Logmars
2D Barcodes	MaxiCode, PDF417, Data Matrix (ECC 200 only) , QR code, Composite Codes, Aztec

8.6 Wireless LAN (Option)

Properties		Wireless LAN I/F				
Hardware	Protocol	IEEE 802.11 b/g/n				
	Enabled Device	WIRELESS PRINTER				
	Operating Temperature	-20°C ~ +85°C				
	Destination	USA	Europe			
	Frequency (Center Channel)	2412 ~ 2462 MHz	2412 ~ 2472 MHz			
	Channel	1 ~ 11 ch	1 ~ 13 ch			
	Spacing	5 MHz				
	Transmission Speed/Modulation	IEEE 802.11b	Transmission Method	Conforming to IEEE 802.11b DSSS method		
			Channel	Depending on the country		
			Data Transmission Speed/Modulation	11/5.5 Mbps: CCK 2 Mbps: DQPSK 1 Mbps: DBPSK		
			IEEE 802.11g	Transmission Method	Conforming to IEEE 802.11g OFDM method DSSS method	
				Channel	Depending on the country	
				Data Transmission Speed/Modulation	54/48 Mbps: 64 QAM 36/24 Mbps: 16 QAM 18/12 Mbps: QPSK 9/6 Mbps: BPSK	
IEEE 802.11n		Transmission Method	Conforming to IEEE802.11n OFDM method			
		Channel	(US)1-11ch (JP/DE)1-13ch			
		Data Transmission Speed/Modulation	20MHz : 6.5M / 7.2M / 13M / 14.4M / 19.5M / 21.7M / 26M / 28.9M / 39M / 43.3M / 52M / 57.8M / 58.5M / 65M /			

Properties		Wireless LAN I/F		
		72.2M(Auto-sensing)		
Antenna	External antenna			
Aerial power	802.11b	Max +15 dBm		
	802.11g	Max +17 dBm		
	802.11n	Max +17 dBm		
Software	Connection mode	Infrastructure, Adhoc		
	Default IP Address	192.168.1.1		
	Default Subnet Mask	255.255.0.0		
	Default ESSID	WIRELESS PRINTER		
	Security	IEEE 802.11i		
		Cryptography	WEP 128 bit, TKIP (WPA), AES (WPA2)	
		Authorization	Open Key (for WEP), PSK	
	Protocol (*)	TCP/IP, Socket, DHCP		
	Wireless LAN Parameter Setting and Status Monitor	Parameter Setting: Command (PC Setting Tool)		

8.7 Interfaces

This section provides information about IO port specifications for the printer.

8.7.1 USB

There are two common USB connectors. Typically, type A is found on hosts and hubs; type B is found on devices. The figure below shows their pinouts.

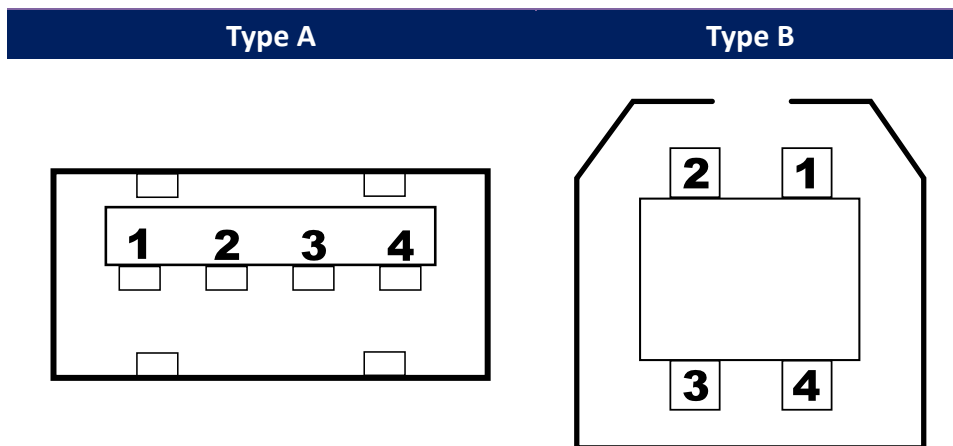

Pin	Signal	Description
1	VBUS	+5V
2	D-	Differential data signaling pair -
3	D+	Differential data signaling pair +
4	Ground	Ground

8.7.2 RS-232C

The RS-232C on the printer is DB9 female. It transmits data bit by bit in asynchronous start-stop mode. The figure below shows its pinout.

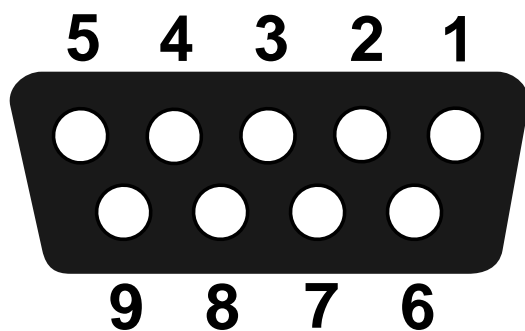

Pin	Signal	Description
1	NA	No Function
2	TxD	Transmit
3	RxD	Receive
4	NA	No Function
5	GND	Ground
6	NA	No Function
7	CTS	Clear to Send
8	RTS	Request to Send
9	NC	No Connection

Host (DB9)			Printer (DB9)		
Signal	Description	Pin	Pin	Description	Signal
CD	Carrier Detect	1	1	No Function	NC
RxD	Receive	2	2	Transmit	RxD
TxD	Transmit	3	3	Receive	TxD
DTR	Data Terminal Ready	4	4	No Function	NC
GND	Ground	5	5	Ground	GND
DSR	Data Set Ready	6	6	No Function	NC
RTS	Request to Send	7	7	Clear to Send	RTS
CTS	Clear to Send	8	8	Request to Send	CTS
CI		9	9	No Function	NC

8.7.3 GPIO

The input and output definition is below.

DB15 Pin No.	Direction (Power/In/Out)	Name	Port No.
1	P	GND	X
2	P	5V	X
3	Input	Start Print	CS4 bit0
4	Input	Feed	CS4 bit1
5	Input	Pause	CS4 bit2
6	Input	Reprint	CS4 bit3
7	P	24V	X
8	P	GND	X
9	NC	NC	X
10	Output	Serv_Req	PC18
11	Output	End_Print	PB21
12	Output	Meida Out	PC17
13	Output	Ribbon Out	PC18
14	Output	Data Ready	PC16
15	Output	OPT_Fault	PA25

Initialize:

- (1) During initialize process, please set all of output port to high for status clear, it mean all of outputs are active low.
- (2) The active level maybe customize needed to modify.
- (3) The input normal state (idle) is high level, so the all of inputs are also active low.

8.7.4 Ethernet

The Ethernet uses RJ-45 cable, which is 8P8C (8-Position 8-Contact). The figure below shows its pinout.

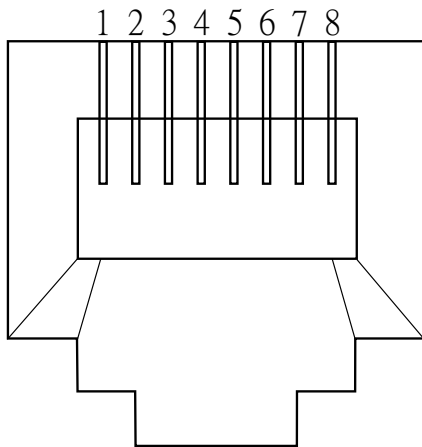

Pin	Signal
1	Transmit+
2	Transmit-
3	Receive+
4	Reserved
5	Reserved
6	Receive-
7	Reserved
8	Reserved