

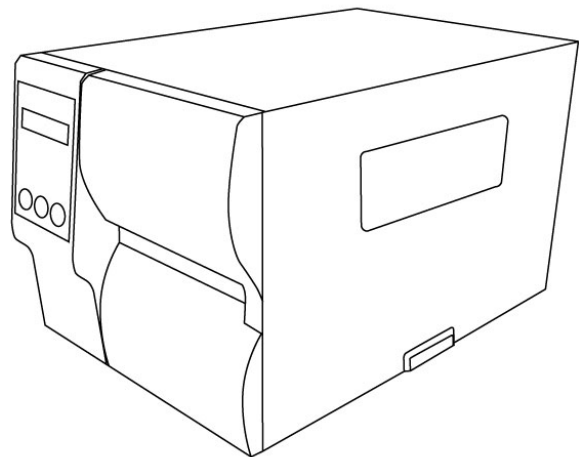

# iX6 Pro Series Printer

## User Manual



<https://www.argox.com>

V1.1

## **Liability Disclaimer**

Argox Information Co., Ltd. takes steps to assure that the company's published engineering specifications and manuals are correct; however, errors do occur. Argox reserves the right to correct any such errors and disclaims any resulting liability. In no event shall Argox or anyone else involved in the creation, production, or delivery of the accompanying product (including hardware and software) be liable for any damages whatsoever (including, without limitation, damages for loss of business profits, business interruption, loss of business information, or other pecuniary loss) arising out of the use of or the results of use of or inability to use such product, even if Argox has been advised of the possibility of such damages.

## **FCC Compliance Statement**

This equipment has been tested and found to comply with the limits for a Class A digital device, pursuant to Part 15 of the FCC Rules. These limits are designed to provide reasonable protection against harmful interference in a residential installation. This equipment generates, uses, and can radiate radio frequency energy and, if not installed and used in accordance with the instructions, may cause harmful interference to radio communications. However, there is no guarantee that the interference will not occur in a particular installation. If this equipment does cause harmful interference to radio or television reception, which can be determined by turning the equipment off and on, the user is encouraged to try to correct the interference by the following measures:

- Reorient or relocate the receiving antenna.
- Increase the separation between the equipment and the receiver.
- Connect the equipment into a different outlet on a different circuit.
- Consult the dealer or an experienced Radio/TV technician for help.

This unit was tested with shielded cables on the peripheral devices. Shielded cables must be used with the unit to ensure compliance. The user is cautioned that any changes or modifications not expressly approved by Argox Information Co., Ltd. could void the user's authority to operate the equipment.

This is a Grade A product. In living environment, the product may cause interference to radio communications. In this case, the user is encouraged to try to correct the interference by effective measures.

設備名稱：條碼印表機 Equipment name		型號（型式）： iX6-250 Pro Type designation (Type)				
單元 Unit	限用物質及其化學符號 Restricted substances and its chemical symbols					
	鉛Lead (Pb)	汞Mercury (Hg)	鎘 Cadmium (Cd)	六價鉻 Hexavalent chromium (Cr <sup>+6</sup> )	多溴聯苯 Polybrominat ed biphenyls (PBB)	多溴二苯醚 Polybrominated diphenyl ethers (PBDE)
印刷電路 板組件	—	○	○	○	○	○
機殼	—	○	○	○	○	○
線材	○	○	○	○	○	○
變壓器	—	○	○	○	○	○
印字頭模 組	—	○	○	○	○	○
<p>備考1. “超出0.1 wt %” 及 “超出0.01 wt %” 係指限用物質之百分比含量超出百分比含量基準值。 Note 1 : “Exceeding 0.1 wt %” and “exceeding 0.01 wt %” indicate that the percentage content of the restricted substance exceeds the reference percentage value of presence condition.</p> <p>備考2. “○” 係指該項限用物質之百分比含量未超出百分比含量基準值。 Note 2 : “○” indicates that the percentage content of the restricted substance does not exceed the percentage of reference value of presence.</p> <p>備考3. “—” 係指該項限用物質為排除項目。 Note 3 : The “-” indicates that the restricted substance corresponds to the exemption.</p>						

**警告使用者:**

這是甲類的資訊產品，在居住的環境中使用時，可能會造成射頻干擾，在這種情況下，使用者會被要求採取某些適當的對策。



**警告** 危險可動部件請遠離手指及身體其他部位。



**Caution**

Ensure to connect the power cord of power adapter to a socket-outlet with earth connection.

**CAUTION:** Risk of Explosion if Battery is replaced by an Incorrect Type. Dispose of Used Batteries According to the Instructions.

**ATTENTION:** Risque d'explosion si la batterie est remplacée par un type incorrect. Mettre au rebut les batteries usagées selon les instructions.

## **Caution**

Any changes or modifications not expressly approved by the party responsible for compliance could void the user's authority to operate the equipment.

All rights reserved. Copyright © 2024 Argox Information Co., Ltd

# Contents

1	Introduction .....	1
1.1	Features.....	1
1.2	Unpacking.....	2
1.3	Understand your printer .....	3
1.3.1	Perspective view .....	3
1.3.2	Back view .....	4
1.3.3	Interior view .....	5
1.4	Printer control panel .....	6
1.4.1	Status LEDs .....	6
1.4.2	Buttons .....	8
2	Get started .....	9
2.1	Attach the power cord .....	9
2.2	Turn on/off your printer .....	10
2.2.1	Turn on your printer .....	10
2.2.2	Turn off your printer .....	11
2.3	Load media.....	12
2.3.1	Prepare media.....	13
2.3.2	Placing media roll.....	13
2.3.3	Media types .....	22
2.4	Load Ribbon .....	24
2.4.1	Placing Ribbon Roll.....	25
3	Printer operation.....	28
3.1	Front Panel .....	28
3.1.1	LCD Function Setting Procedure .....	29
3.2	Printing Media Calibration & Configuration .....	35
3.3	Printing a Configuration Report .....	36
3.4	Resetting to Factory Default Settings.....	46
3.5	Media sensing .....	47
3.5.1	Transmissive sensor .....	47
3.5.2	Reflective sensor .....	48
3.5.3	Adjust Position of Label Sensor.....	49
3.6	Communications .....	50
3.6.1	Interfaces and Requirements.....	50
3.7	Driver installation.....	52
3.7.1	Installing a Plug and Play printer driver (for USB only) .....	53
3.7.2	Installing a Printer Driver (for other interfaces except USB).....	58

4	Maintenance .....	64
4.1	Cleaning.....	65
4.1.1	Printhead.....	65
4.1.2	Platen Roller .....	66
5	Troubleshooting .....	67
5.1	Printer issues .....	67
5.2	Media issues.....	68
5.3	Ribbon issues.....	69
5.4	Other issues.....	70
6	Specifications .....	71
6.1	Printer.....	71
6.2	Media & Ribbon .....	72
6.3	Electrical and operating environment.....	72
6.4	Physical dimension .....	73
6.5	Fonts, Barcodes, and Graphics Specification .....	73
6.6	Wireless LAN (Option).....	76
6.7	Interfaces.....	79
6.7.1	USB .....	79
6.7.2	RS-232C.....	80
6.7.3	GPIO .....	81
6.7.4	Ethernet .....	82
7	Dimensions.....	83

# 1 Introduction

Thank you for purchasing an Argox iX6 Pro Series industrial barcode printer. This manual provides information about how to set up and operate your printer, load media, ribbon and solve common problems. Illustrations are provided to help you quickly become familiar with the printer.

## 1.1 Features

- **Fast Print Speed**  
Max. 6 IPS, completely satisfy the demands in its class.
- **Communication**  
Standard: Ethernet, dual USB hosts, USB device, and RS-232.  
Option: Wi-Fi and GPIO
- **Online management**  
Web management and SNMP v2 support
- **Dual USB host function**  
Stand-alone mode of scanner/ keyboard multiple data entry devices
- **New media calibration**  
Intelli mode & Smart mode

## 1.2 Unpacking

Make sure all of the following items are included in your package.

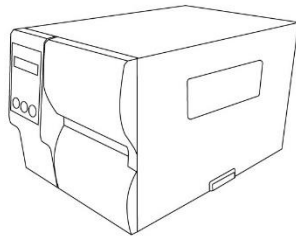

Printer

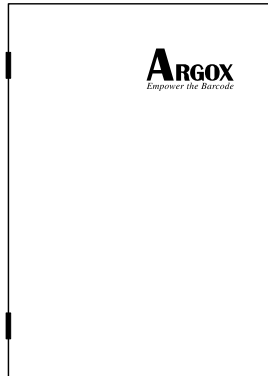

Quick Installation  
Guide

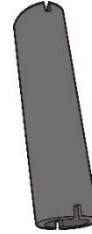

1" ID Core for Ribbon

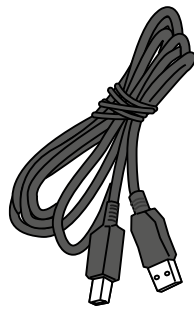

USB Cable

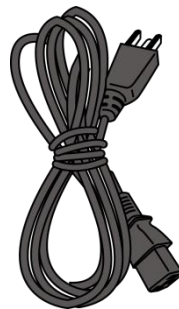

AC Power Cord

When you receive the printer, open the package immediately and inspect for shipping damage. If you discover any damage, contact the shipping company and file a claim. Argox is not responsible for any damage incurred during shipping. Save all package materials for the shipping company to inspect.



**Note** If any item is missing, please contact your local dealer.



# 1.3 Understand your printer

## 1.3.1 Perspective view

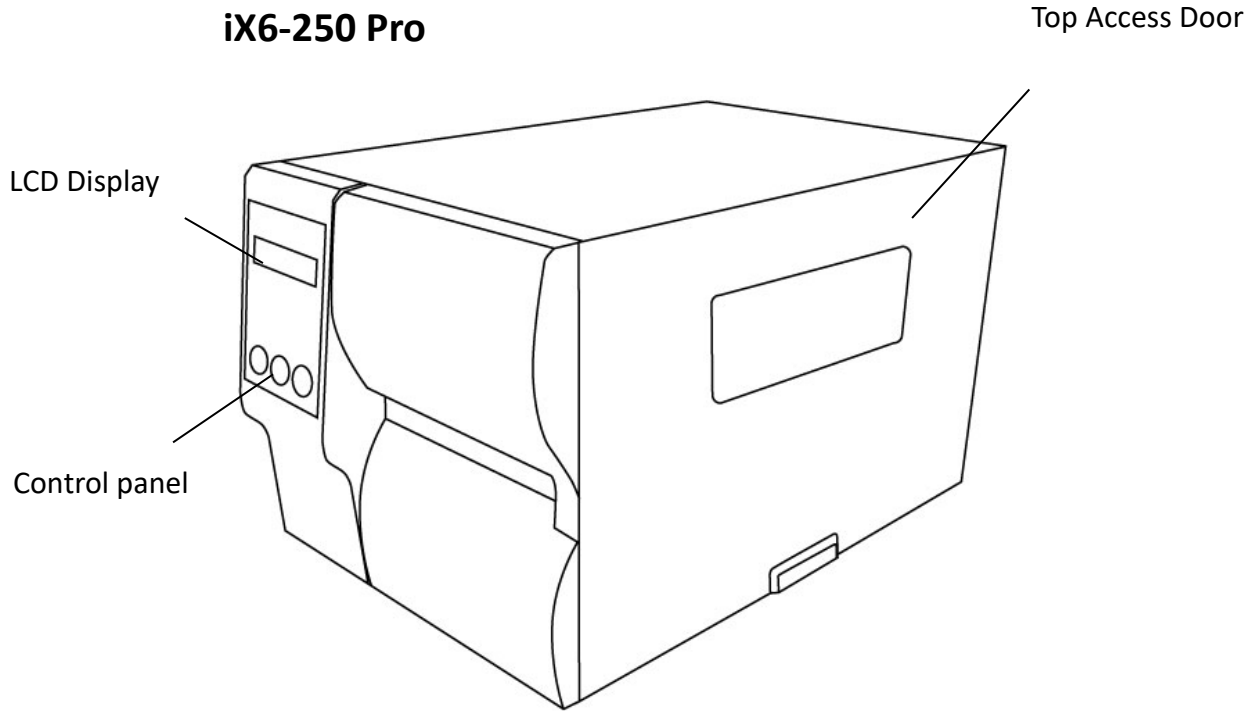

## 1.3.2 Back view

### iX6-250 Pro Standard

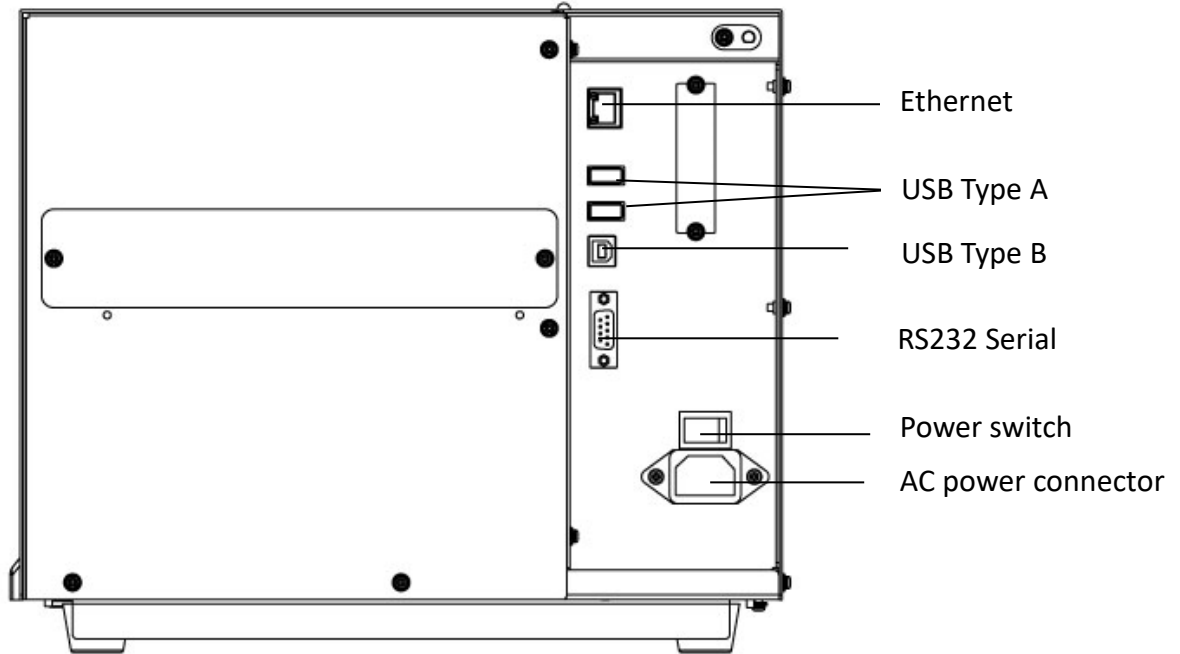

### iX6-250 Pro Optional

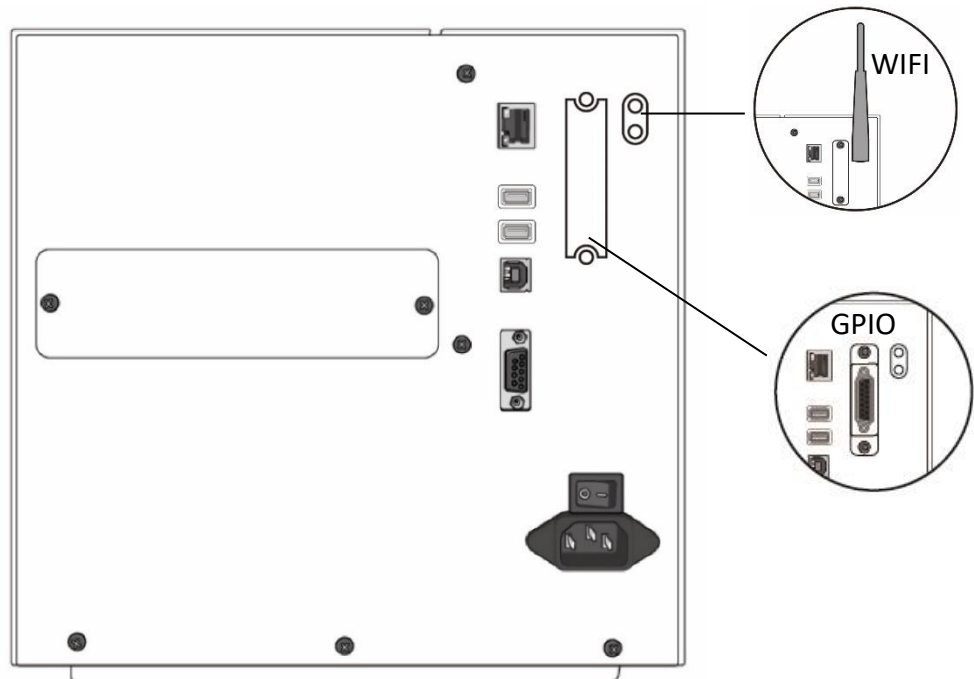

## 1.3.3 Interior view

### Internal Parts and Features

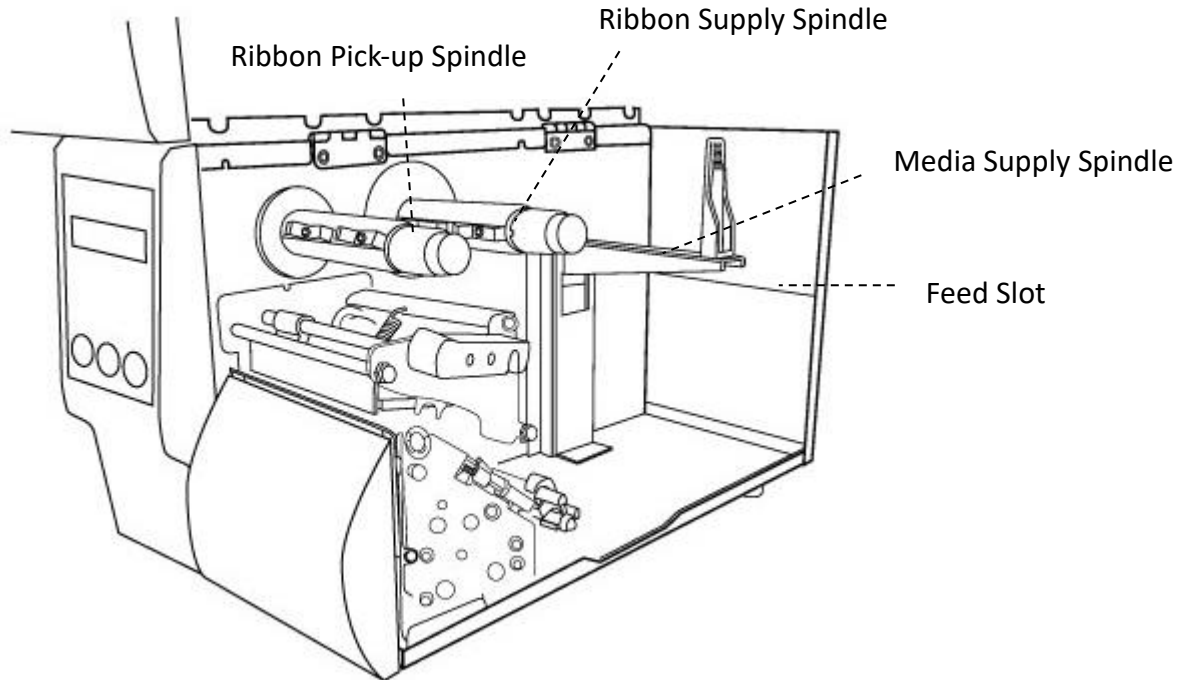

### Rotate Head Latch

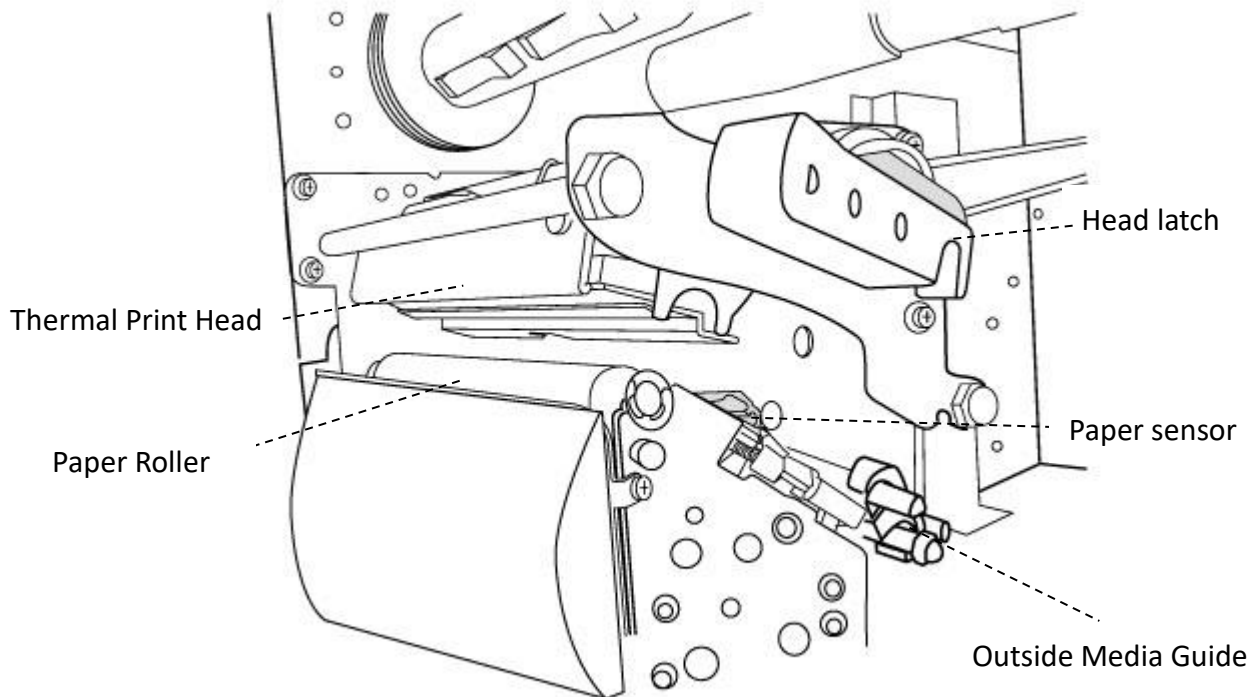

## 1.4 Printer control panel

There are three LEDs on the front panel - READY, MEDIA and RIBBON. These indicators display operation status of the printer. Three Buttons – FEED, PAUSE, and CANCEL can control printer simple functions.

### 1.4.1 Status LEDs

Status LEDs help you check printer's conditions. The following tables show the status LEDs and the conditions they indicate.

LCD Display	READY	MEDIA	RIBBON	Description
READY	ON	ON	ON	In the ready mode
PRINT HEAD HEAT	ON	Blinking	ON	Print head needs to cool down.
COMMAND ERROR	ON	Blinking	Blinking	A command error was found while checking the command sequence.
EEPROM ERROR	ON	Blinking	Blinking	An EEPROM for back-up cannot be read/written properly.
MEMORY ERROR	ON	Blinking	Blinking	<ul style="list-style-type: none"> <li>· An error has occurred in writing data into USB memory or flash memory.</li> <li>· An erase error has occurred in formatting USB memory or flash memory.</li> <li>· Saving failed because of the insufficient capacity of USB memory or flash memory.</li> <li>· Firmware update has error.</li> </ul>
CANCEL ...	Blinking	ON	ON	Press CANCEL KEY to interrupt and delete a print task
CLEAR FLASH	Blinking	ON	ON	Clear flash memory.

LCD Display	READY	MEDIA	RIBBON	Description
<b>CUTTER FAILED</b>	<b>Blinking</b>	<b>ON</b>	<b>ON</b>	Cutter has failed, or there is paper jam inside the cutter.
<b>MEMORY FULL</b>	<b>Blinking</b>	<b>ON</b>	<b>ON</b>	Printer buffer is full caused by the loaded soft fonts, graphics or forms.
<b>MEMORY INITIALIZED</b>	<b>Blinking</b>	<b>ON</b>	<b>ON</b>	USB Memory is being initialized.
<b>PAUSE</b>	<b>Blinking</b>	<b>ON</b>	<b>ON</b>	Printer is in PAUSE status. Media sensor cannot index label gaps
<b>PRINTHEAD BROKEN</b>	<b>Blinking</b>	<b>ON</b>	<b>ON</b>	Head broken error
<b>PRINT HEAD OPEN</b>	<b>Blinking</b>	<b>ON</b>	<b>ON</b>	Head latch is not closed.
<b>RESET</b>	<b>Blinking</b>	<b>ON</b>	<b>ON</b>	Press CANCEL KEY + POWER ON to reset NVR table.
<b>SERIAL IO ERROR</b>	<b>Blinking</b>	<b>ON</b>	<b>ON</b>	The format or baud rate of the RS232 communication is inconsistent between the printer and host.
<b>SELF TEST ...</b>	<b>Blinking</b>	<b>ON</b>	<b>ON</b>	Press FEED KEY + POWER ON to print the self-test label.
<b>UPGRADING FW.</b>	<b>Blinking</b>	<b>ON</b>	<b>ON</b>	Printer is receiving data
<b>RIBBON OUT</b>	<b>Blinking</b>	<b>ON</b>	<b>Blinking</b>	Ribbon is not installed or end-of-ribbon occurred.
<b>CALIBRATION . ..</b>	<b>Blinking</b>	<b>Blinking</b>	<b>ON</b>	Press PAUSE KEY + POWER ON to calibrate media.

LCD Display	READY	MEDIA	RIBBON	Description
<b>MEDIA OUT</b>	<b>Blinking</b>	<b>Blinking</b>	<b>ON</b>	Media is not installed or used up. Printer fails to detect the media gap. The media sensor is out of range during calibration. The label has run out. The last label has been issued normally and the label has run out.
<b>PAPER JAM</b>	<b>Blinking</b>	<b>Blinking</b>	<b>ON</b>	A paper jam occurred during paper feed.

## 1.4.2 Buttons

There are three buttons, each with two basic functions.

Button	Function 1	Function 2
FEED	<ul style="list-style-type: none"> <li>• Feed a label</li> </ul>	
PAUSE	<ul style="list-style-type: none"> <li>• Pause printing</li> </ul>	<ul style="list-style-type: none"> <li>• Press again to resume printing</li> </ul>
CANCEL	<ul style="list-style-type: none"> <li>• Interrupt and delete a print task</li> </ul>	<ul style="list-style-type: none"> <li>• Force printer to continue after an error is solved.</li> </ul>

## 2 Get started

This chapter describes how to set up your printer.

### 2.1 Attach the power cord

1. Make sure the power switch is set to the **OFF** position.
2. Place the printer within cable distance from the host (USB or Serial cable.).
3. Isolate the power cord from other electrical cables.
4. Plug the other end of the AC power cord into the wall socket.

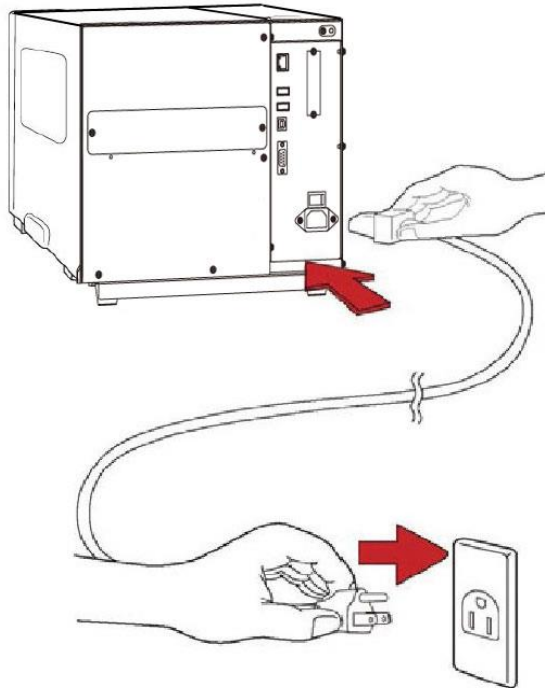

**Warning** Do not plug the AC power cord with wet hands, or operate the printer and the power supply in an area where they may get wet. Serious injury may result from these actions!

## 2.2 Turn on/off your printer

When your printer is connected to a host (a computer), it is good to turn on the printer before turning on the host, and turn off the host before turning off the printer.

### 2.2.1 Turn on your printer

1. To turn on your printer, turn on the **Power Switch** as below. The “I” is the **ON** position.

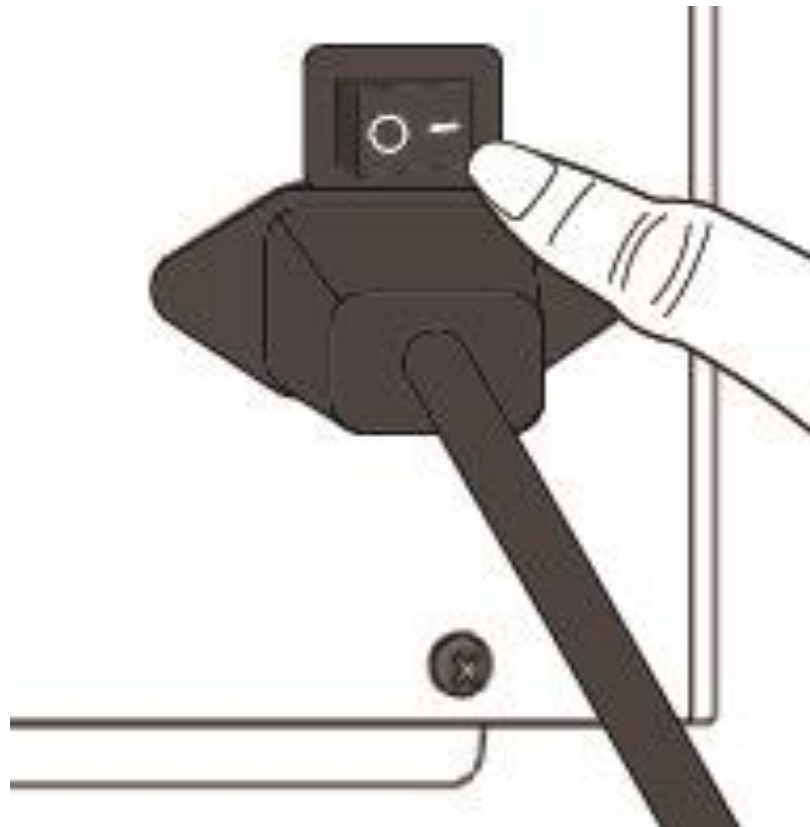

2. READY、MEDIA and RIBBON LEDs are solid blue. Then READY LED turns off for few seconds while LCD screen shows firmware version. LCD screen will show Ready to print and READY LED will back to solid blue.



## 2.2.2 Turn off your printer

1. Make sure READY · MEDIA · RIBBON LEDs are solid blue before turning off the printer.
2. To turn off your printer, turn off the **Power Switch** as below. The “O” is the **OFF** position.

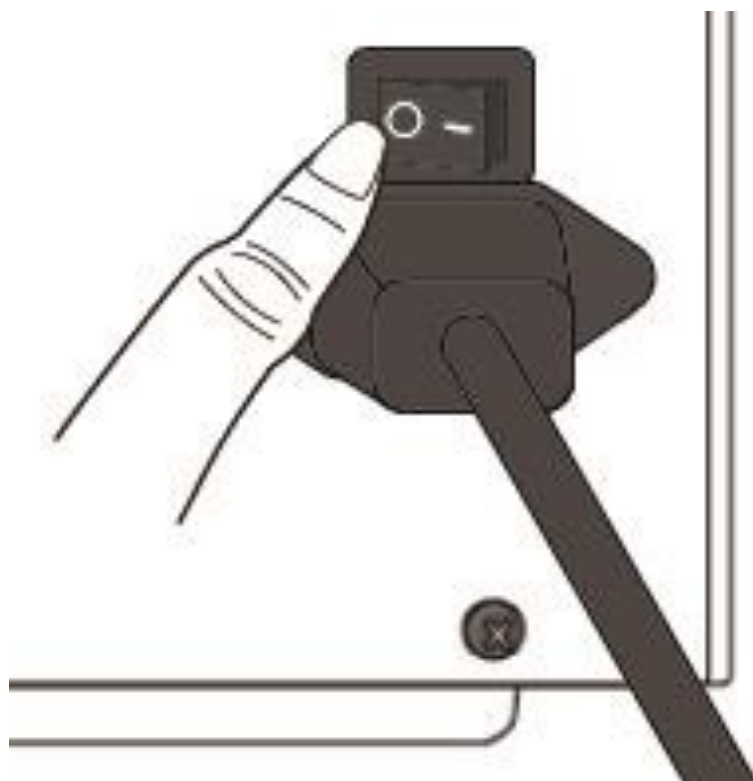

**Caution** Do not turn off your printer during data transmitting.

## 2.3 Load media

The iX6 Pro Series printers offer three different loading modes: standard, peel-off, or with a cutter.

- **Standard mode** allows you to collect each label freely.
- **Peel-off mode** peels backing material away from the label as it prints. After the label is removed, the next label prints.
- **Cutter mode** automatically cuts the label after it prints. There are rotate cutter and guillotine cutter types to cut media.



**Important** The first time to use peel-off mode and cutter mode. Make sure to enable the PEELER INSTALLED or CUTTER INSTALLED setting in front panel. For more information about panel setting, go to CH 3.1.1 [LCD Function Setting Procedure](#).

### Thermal Transfer Media Loading Instructions

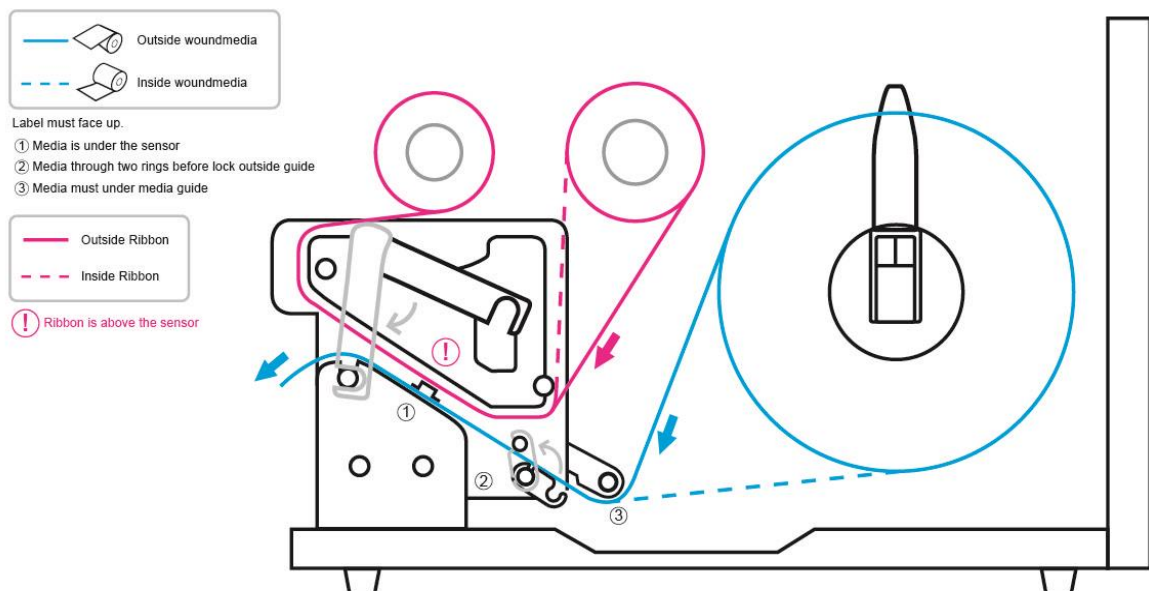

## 2.3.1 Prepare media

The inside wound and outside wound media roll can be loaded into the printer the same way. In case the media roll is dirty during shipping, handling or storage, remove the outside length of the media. It helps avoid dragging adhesive and dirty media between the print head and platen roller.

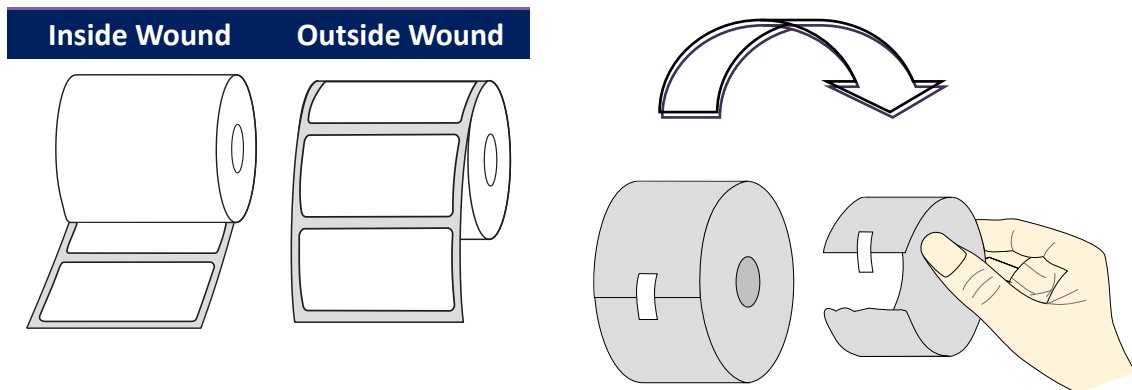

## 2.3.2 Placing media roll

### Load Media in Standard Mode

- 1 Lift the top cover to expose the media compartment.

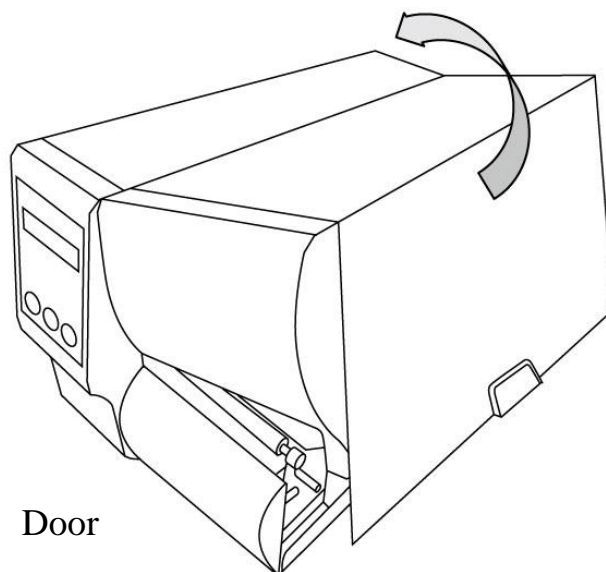

- 2 Insert the media roll into the media supply spindle and move the media guide to the inside.

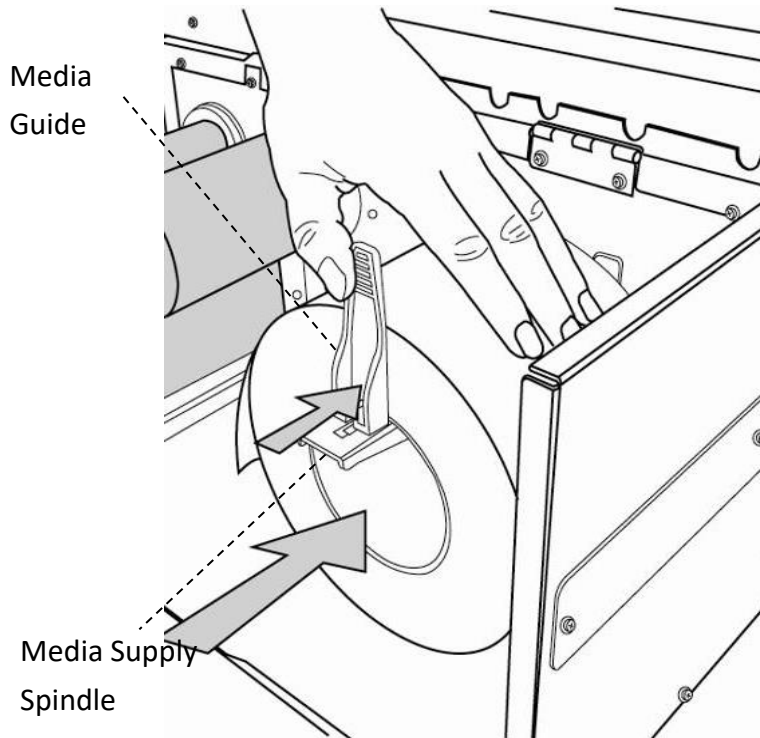

3. Turn the head latch counterclockwise and open the outside media guide counterclockwise for media insert.

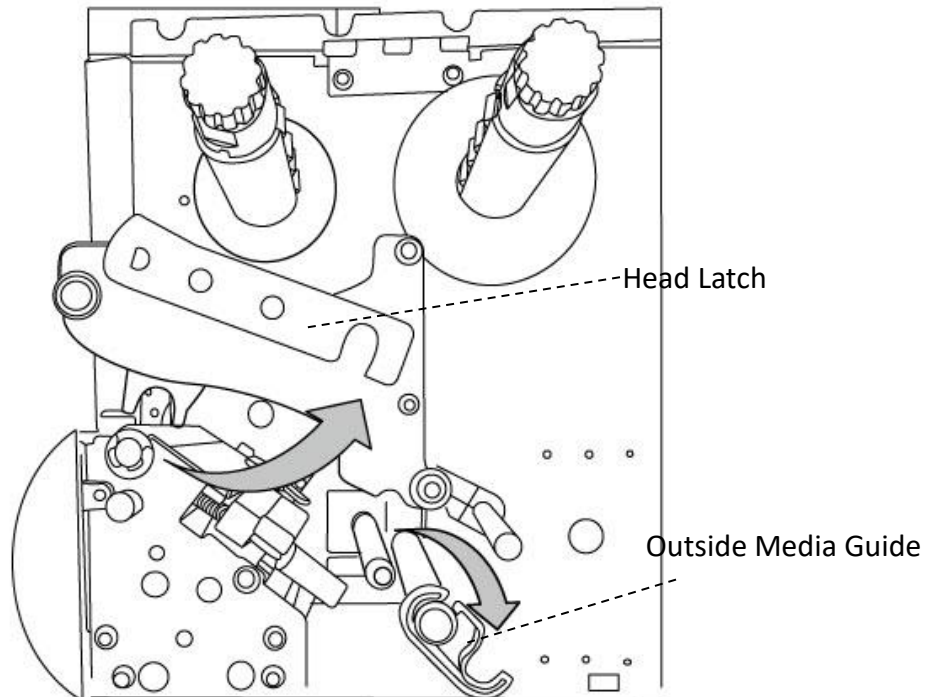

4. Label must face up when lead the media through the print head module. Media is under “media guide” and through two rings before lock “Outside Media Guide”. Then, under the paper sensor guide module and over the roller.

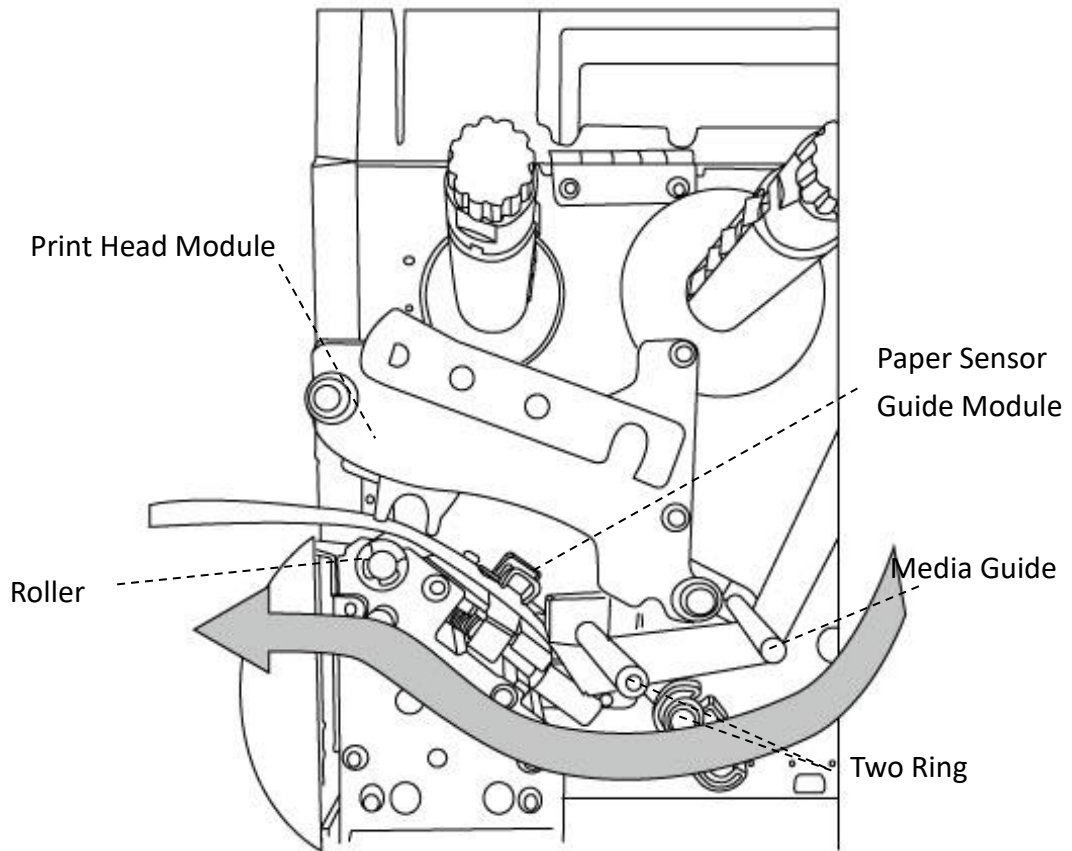

5. Return the outside media guide and hook the head latch.

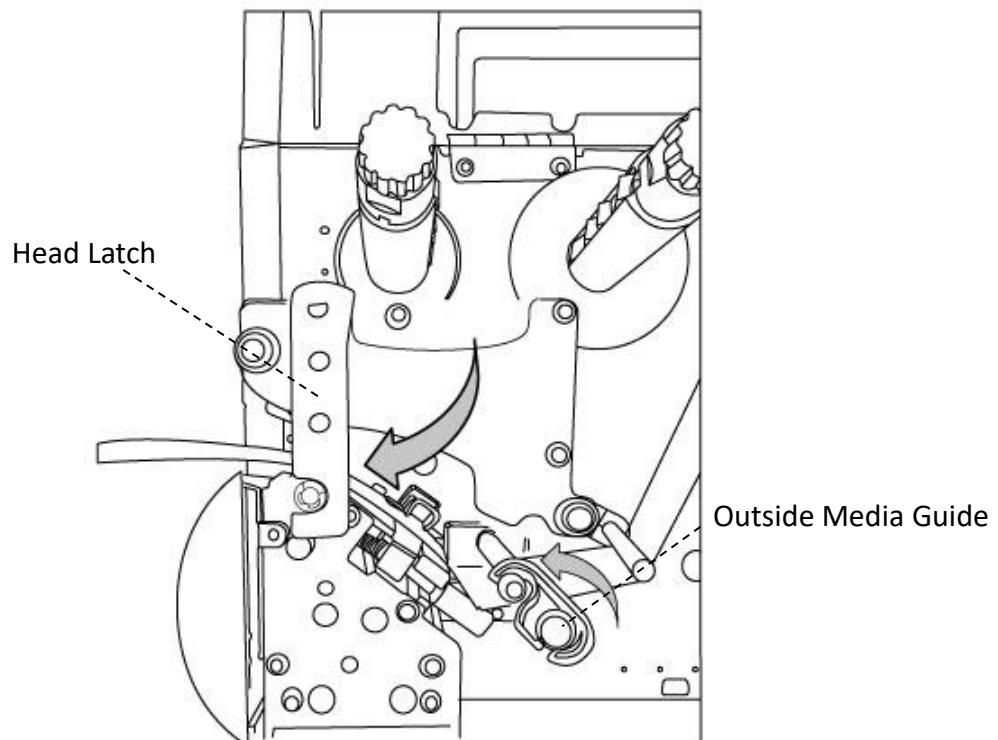

6. Close the top cover.

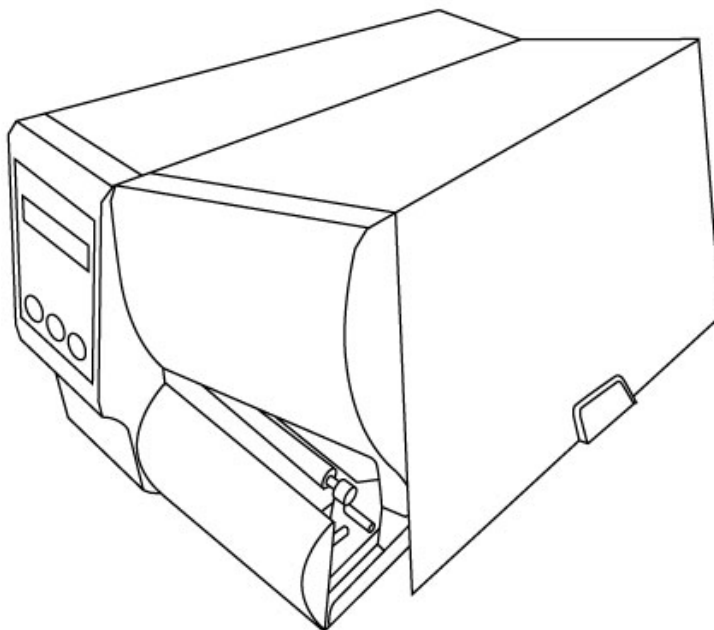

7. Press the FEED button if the printer is already on.

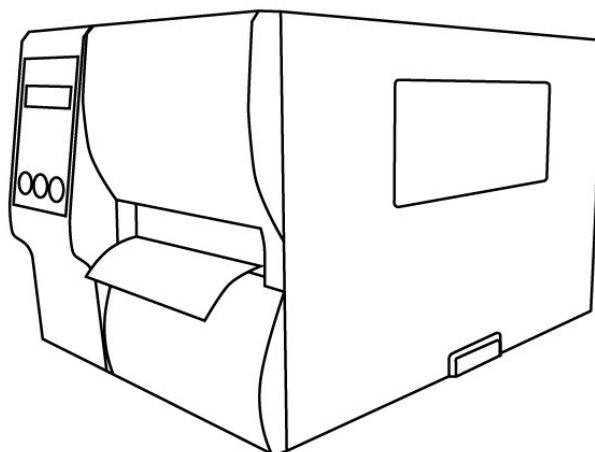

---

**Important**

After the media is loaded, please perform [media calibration](#) to calibrate the label sensor before printing.

---



**Note** Make sure the die-cut media's label length is at least 25mm or longer, for direct thermal printing in tear-off mode with perforation.

---

## Load Media in Peel off Mode

### Attention:

**To prevent the backing label from rolling into the roller, please stick the supplied sponge (50mm(L) x 5mm(W) x 5mm(H)) on top of the peeler bracket after installing the peeler module. The sponge should be placed 1mm from the bottom edge of the roller and 10mm from the right side of the bracket.**

For detailed instructions on installing the sponge, please refer to the Argox quick installation guide. Quick installation guide download link:

[https://www.argox.com/docfile/usermanual/iX4\\_iX6\\_peeler\\_QIG\\_v1.1.pdf](https://www.argox.com/docfile/usermanual/iX4_iX6_peeler_QIG_v1.1.pdf)

The following are the steps to install the label roll. Steps 1 to 3 given below are the similar with those in Standard Mode.

1. Lift the top cover to expose the media compartment.
2. Insert the media roll into the media supply spindle and move the media guide to the inside.
3. Turn the head latch counterclockwise and open the outside media guide for media insert.
4. From the leading end of the media roll remove enough labels to expose 6-inches of backing paper.

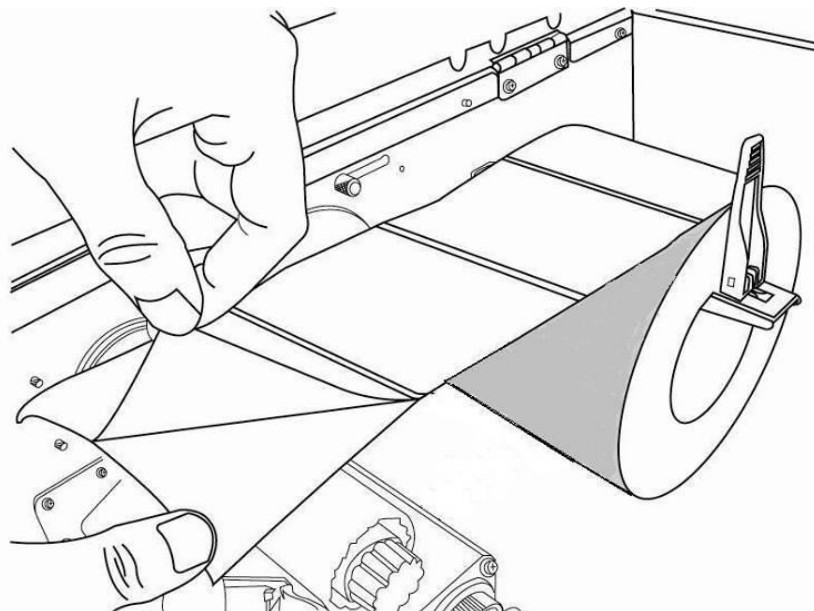

5. Lead the media backing paper under the print head module. For more specific leading media refer to standard mode [step 4](#).

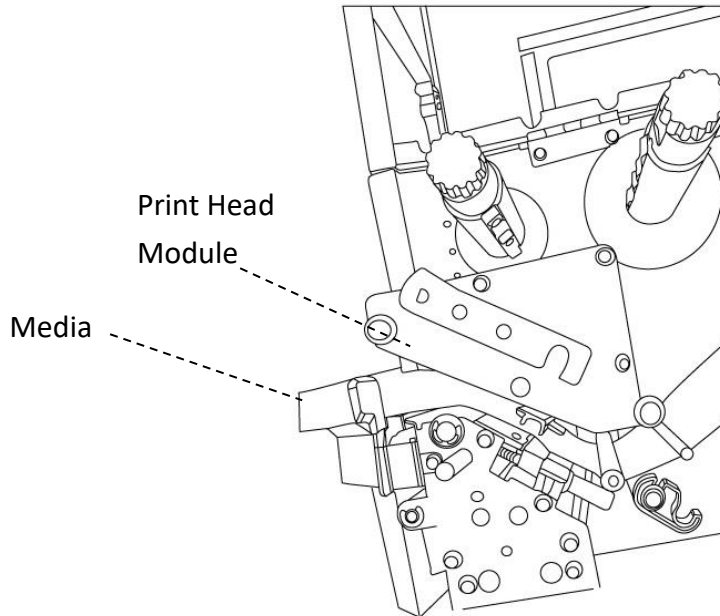

6. Push down the peel-off mechanism release lever and lead the media backing paper behind the peeler module.

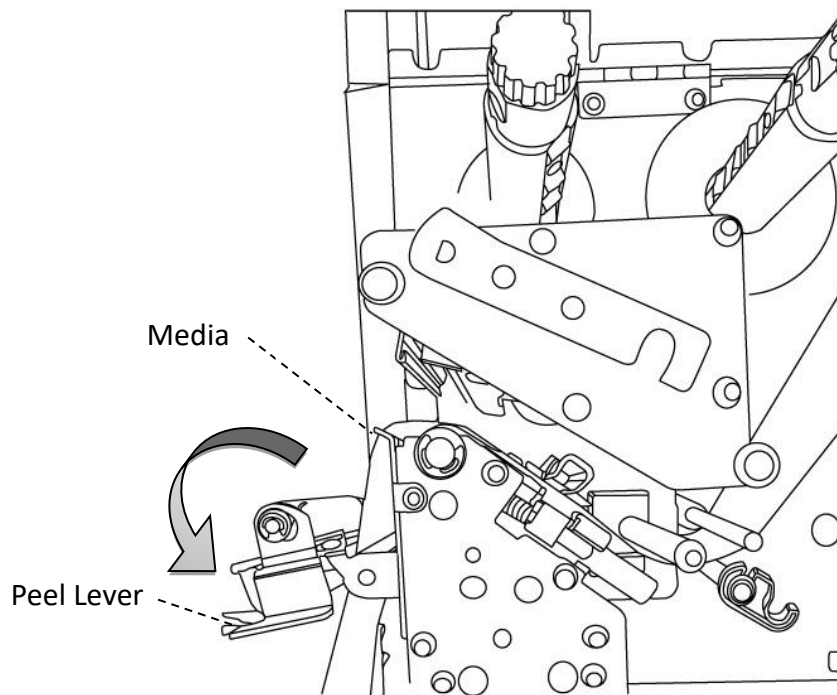



7. Close the peeler module using the peel-off mechanism release lever. Return the outside media guide and hook the head latch.

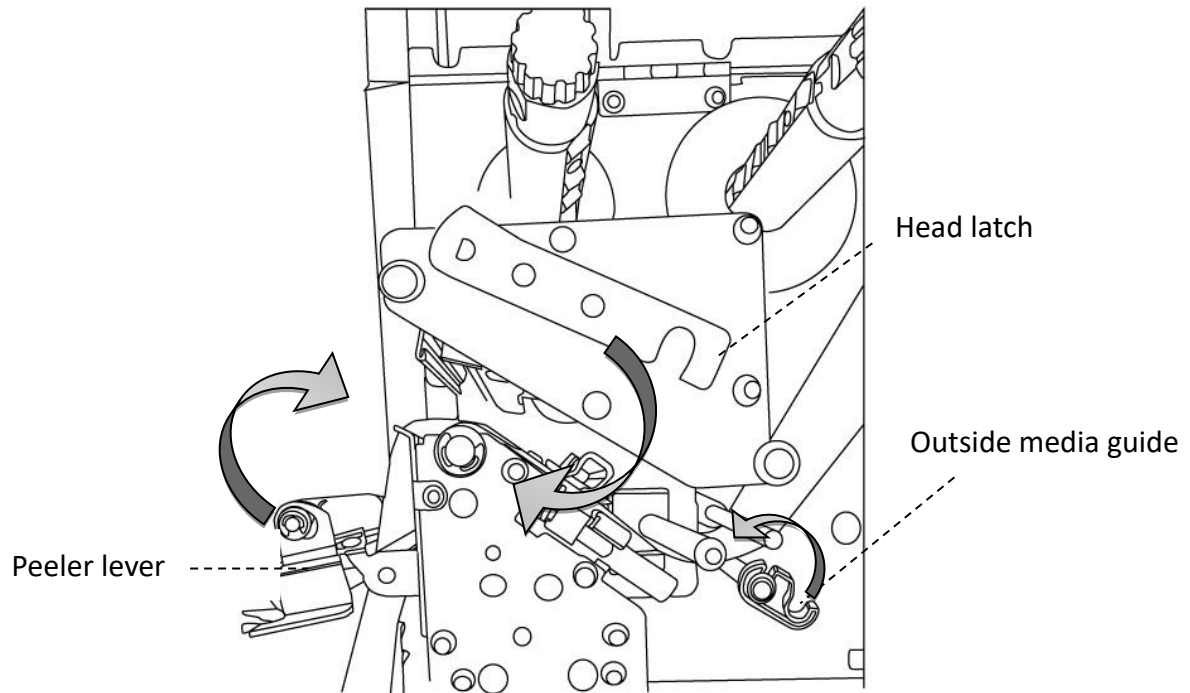

8. Close the top cover and turn on the printer or press the FEED button if the printer is already on.

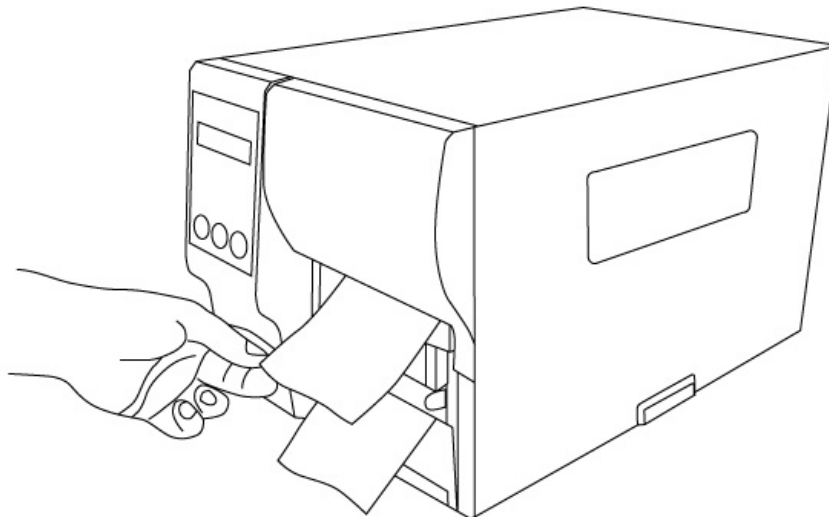

---

**Important**

After the media is loaded, please perform [media calibration](#) to calibrate the label sensor before printing.

---

## Load Media in Rotary Cutter Mode

Steps 1 to 3 are the similar with “Standard Mode”.

1. Lift the top cover to expose the media compartment.
2. Insert the media roll into the media supply spindle and move the media guide to the inside.
3. Turn the head latch counterclockwise and turn on the outside media guide.
4. Insert the media under the print head module and under the paper sensor guide over the roller. For more specific leading media refer to [standard mode step 4](#).

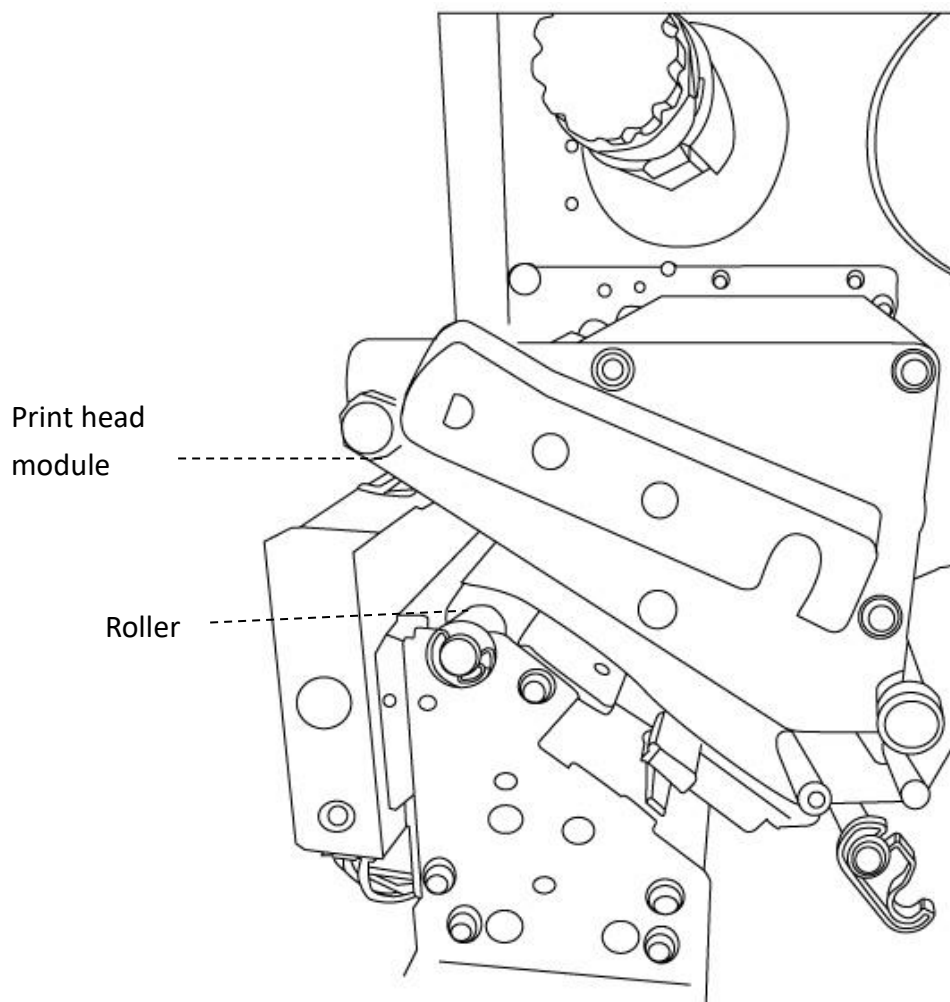

- Return the outside media guide and hook the head latch.

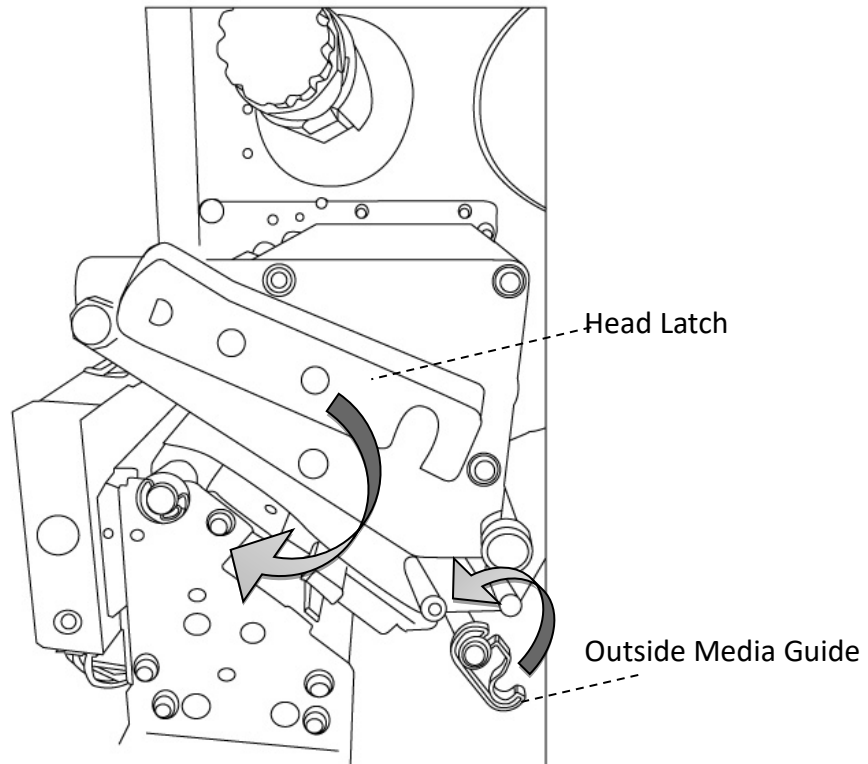

- Close the top cover and turn on the printer or press the FEED button if the printer is already on. The printer will then feed the labels through the cutter automatically.

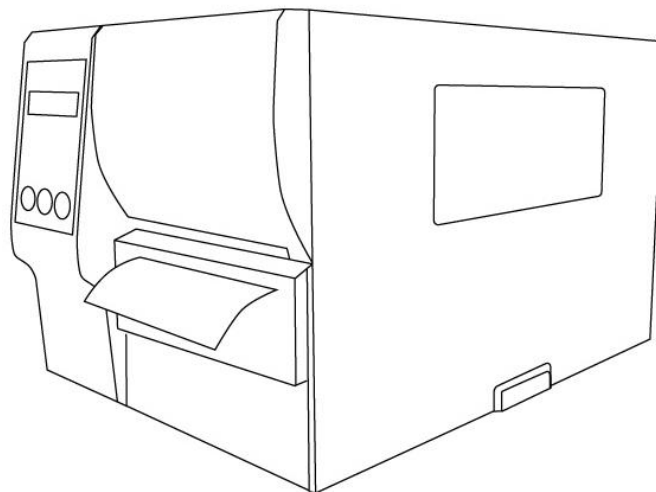

---



**Important**



After the media is loaded, please perform [media calibration](#) to calibrate the label sensor before printing.

---

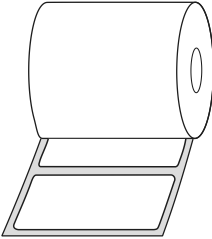
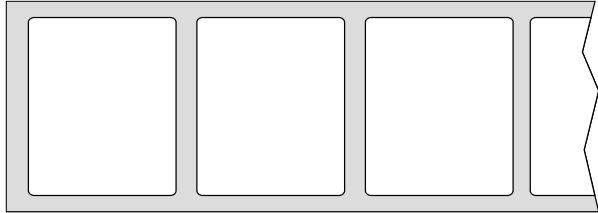
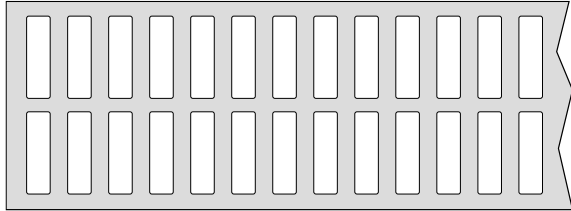
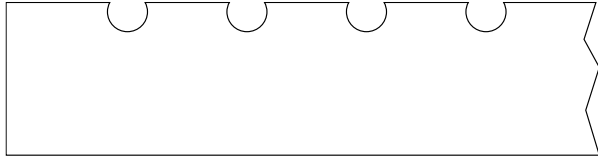
### 2.3.3 Media types

Your printer supports various media types, including non-continuous media, continuous media, and fanfold media. The following table provides details about them.

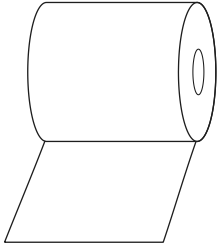
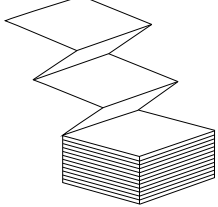
Media Type	Looks Like	Description
<p><b>Non-Continuous Media</b></p>	      	<p>Non-continuous media is the typical media for bar code printing. Labels and tags are made of various materials, such as paper, fabric or cardstock, and are separated by gaps, holes, notches or black marks. Many labels are self-adhesive with liners, while some are linerless.</p>

Media Type	Looks Like	Description
<b>Continuous Media</b>		<p>Continuous media does not have gaps, holes, notches or black marks. It allows you to print data anywhere on the media. A cutter may be used for splitting labels. Mostly it is used for direct thermal printing.</p>
<b>Fanfold Media</b>		<p>Fanfold media is in continuous form, but it can be used as non-continuous media, because its labels are separated by folds. Some fanfold media also has black marks or liners.</p>
<b>Tag Media</b>		<p>Tag media is usually made from a heavy paper, with center hole to index. It does not have adhesive or a liner, and it is typically perforated between tags. The media may also have black marks or other separations.</p>

## 2.4 Load Ribbon

The following steps only apply to thermal transfer printing mode.

Direct thermal does not need ribbon to be installed.

iX6 Pro Series printers apply to both Inside wound ribbon and Outside wound ribbon.

Printers can switch automatically.



### Note

- Media and ribbon types should be matched to provide with optimal print results.
- Always use ribbon that is wider than the media to protect the print head from wear.

## 2.4.1 Placing Ribbon Roll

1. Lift the top cover to expose the media compartment.

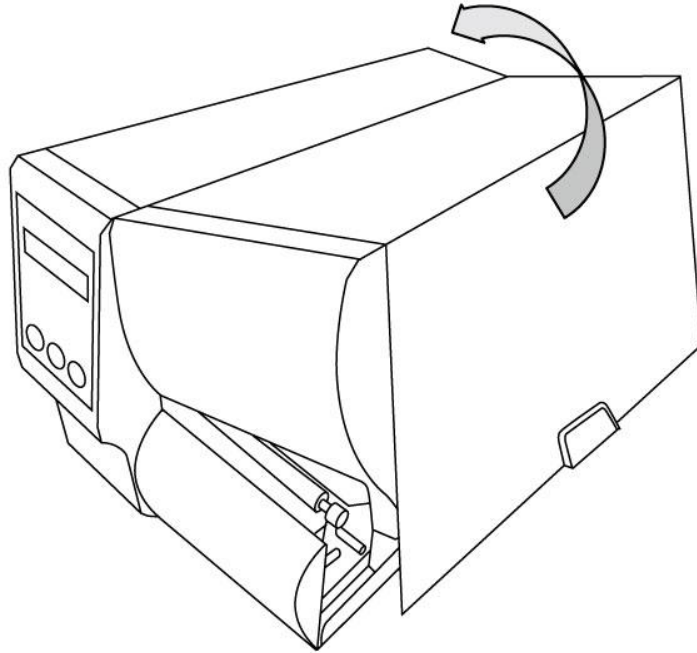

2. Turn the head latch counterclockwise.

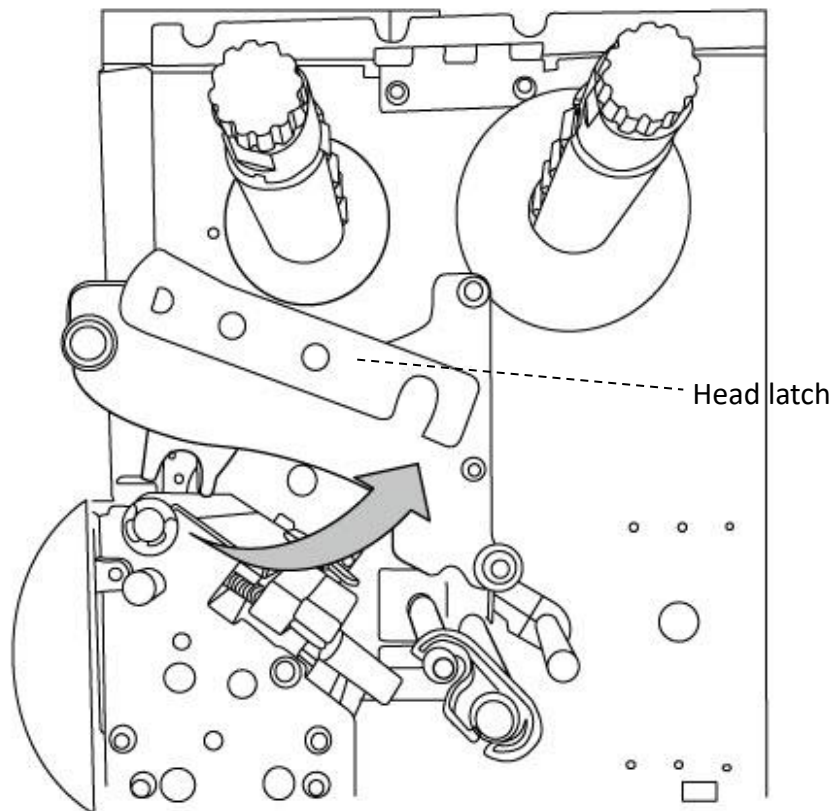

3. Unwrap the ribbon and separate the ribbon roll from the bare core. Insert the ribbon roll onto the ribbon supply spindle.

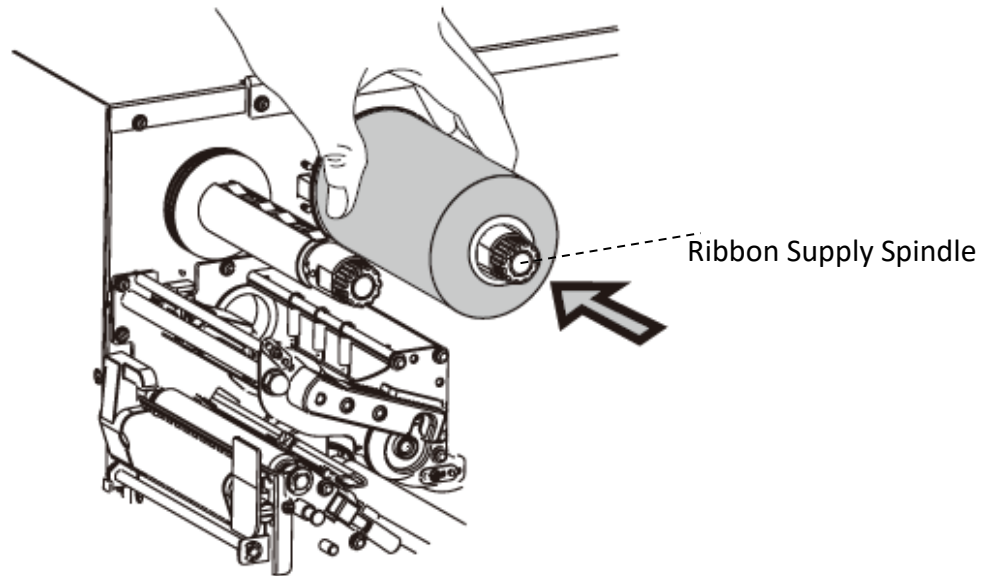

4. Lead the ribbon through the print head module. Attach the edge of the ribbon onto the bare core and wind it a bit onto the core. Make sure the coating side of the ribbon is face down.

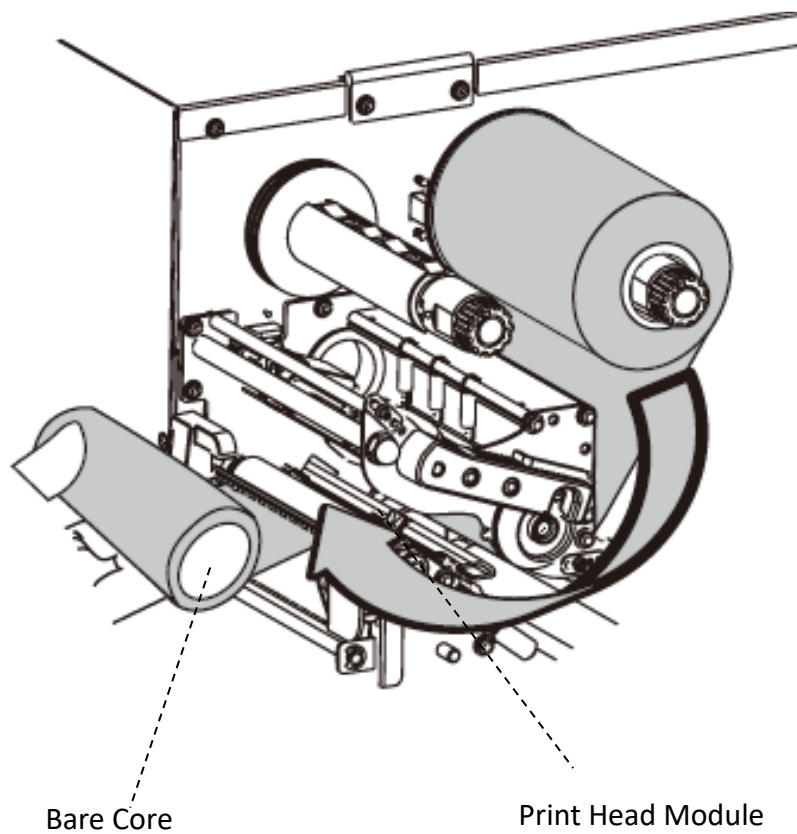



5. Insert the core onto the ribbon pick-up spindle. Turn the pick-up spindle to ensure the ribbon is tightly wound.

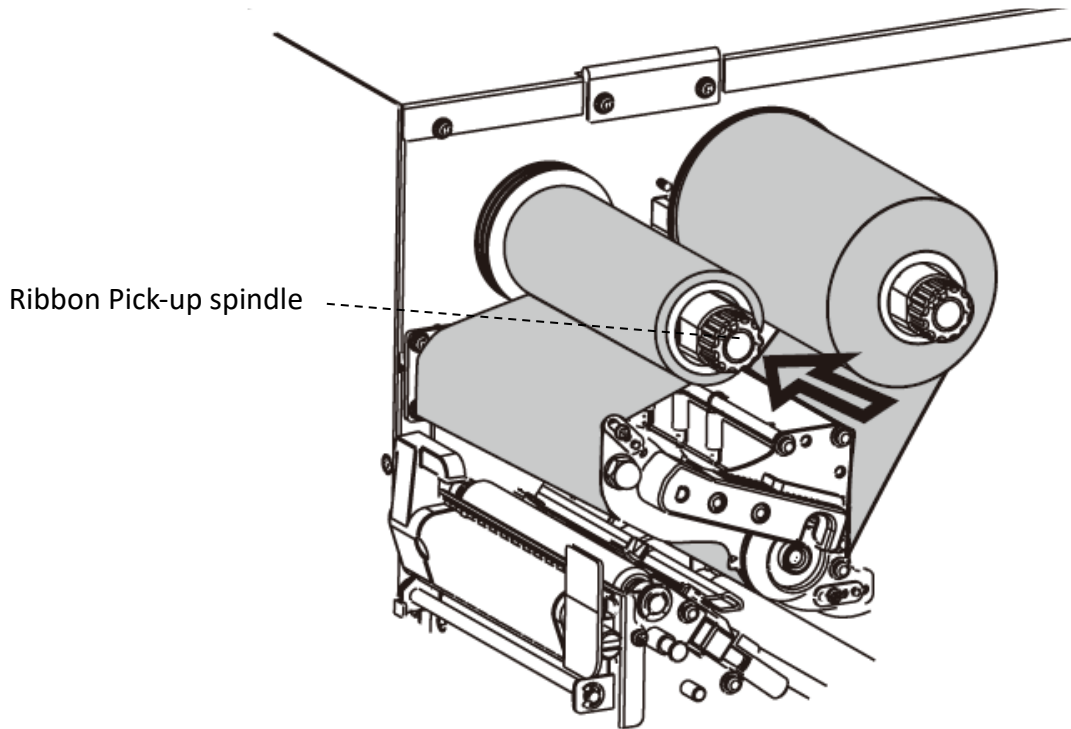

6. Close the top cover and turn on the printer.

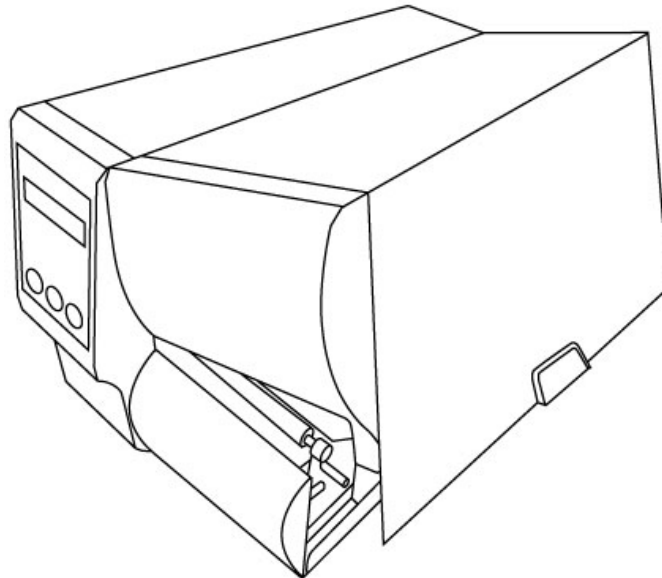

# 3 Printer operation

This chapter provides more specific information about printer operation.

## 3.1 Front Panel

Change settings via buttons on panel:

Buttons	Function
PAUSE+CANCEL	Press to enter setting mode. Press again to exit setting mode and return to normal mode.
FEED	Press to show next parameter.
PAUSE	Press to show next setting item.
CANCEL	Selects and saves a parameter to permanent FLASH memory. Unless changed via panel or command the parameter is saved even if you restart the printer.



**Warning** *Do not change settings during printing or sending printing data.*

### 3.1.1 LCD Function Setting Procedure

The following procedure is an example of setting procedure to direct thermal printing mode:

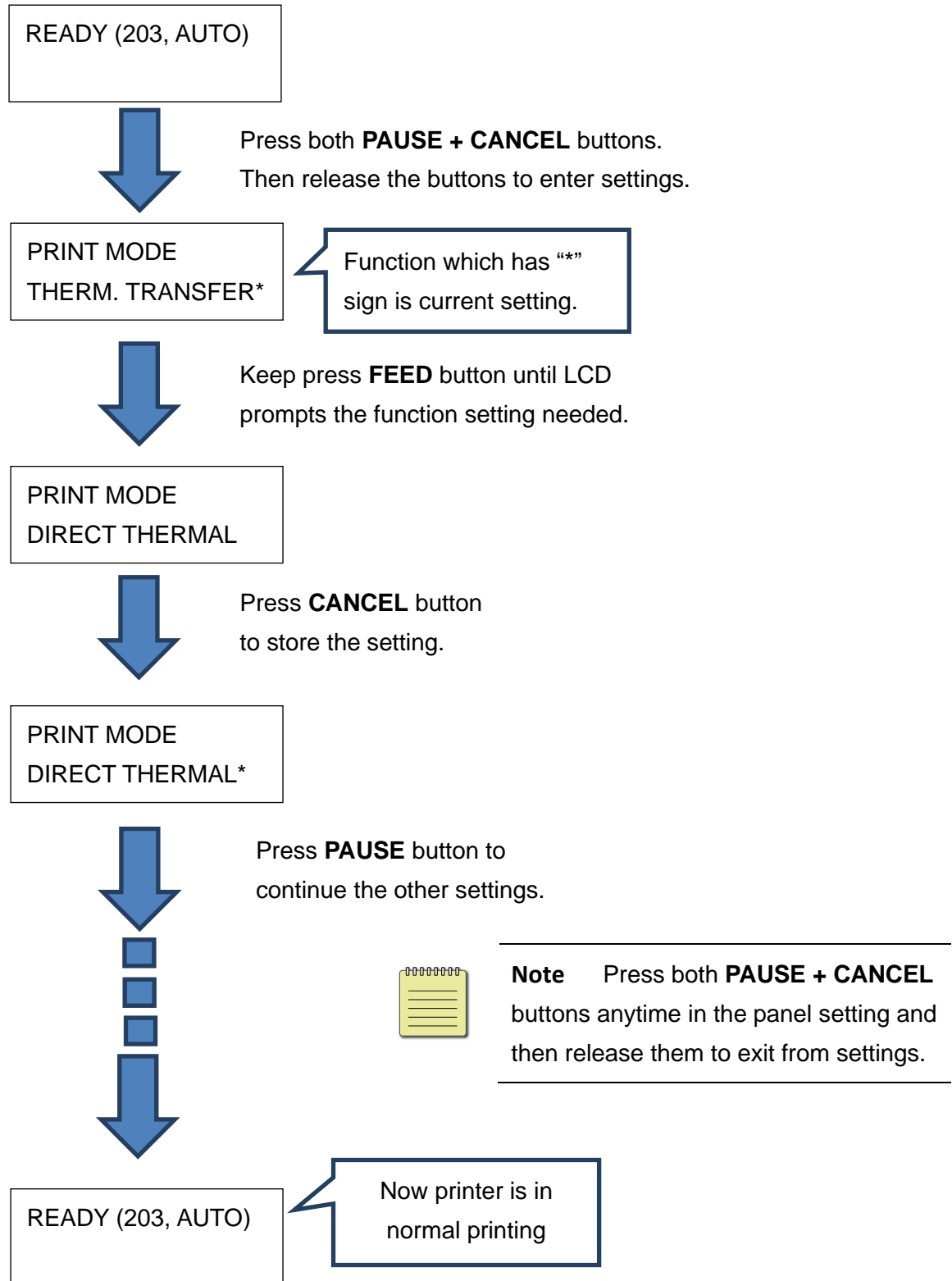

Press **PAUSE + CANCEL over 5 seconds** to set different languages.

Item	Range	Factory Default
LANGUAGE	ENGLISH, FRENCH, GERMAN, ITALIAN, SPANISH, PORTUGUESE,	ENGLISH

Press **PAUSE + CANCEL less than 1 second** to set printer function.

NO.	Item	Range	Factory Default	Remarks
<b>1</b>	PRINT MODE	THERM. TRANSFER DIRECT THERMAL	THERM. TRANSFER	(Restart printer after change setting)
<b>2</b>	CALIBRATION MODE	INTELLI PRINT SMART PRINT	INTELLI PRINT	INTELLI PRINT : Just install labels, latch print module, press FEED button once, and then the printer will feed 1-2 labels to detect next gap / black mark before printing. SMART PRINT : Print from the first label immediately according to label length setting. Make sure to carefully align label bottom edge at the tear-off position before printing.  (Restart printer after change setting)
<b>3</b>	CONTROL CODE SET	STANDARD ALTERNATIVE ALTERNATIVE 2	<sup>1</sup> STANDARD	Available only in PPLA printer language. (Restart printer after change setting)
<b>4</b>	CUT OFFSET	PEEL -015 ~ 015 mm	000 mm	To adjust cut and peel positions.

<b>5</b>	TPH VER OFFSET	-009~009 mm	000 mm	To adjust offset of vertical print position.
<b>6</b>	RECOVER PRINT	ENABLE, DISABLE	ENABLE	Will not reprint after recovering from media-out or ribbon-out errors.
<b>7</b>	CUTTER INSTALLED	NO YES	NO	(Restart printer after change setting)
<b>8</b>	PEELER INSTALLED	NO YES	NO	
<b>9</b>	STANDLONE FORM FONT	NO YES	NO	Available only in PPLB printer language. (Restart printer after change setting)
<b>10</b>	WIN. CON. LEN.	0 ~ 254 mm	000 mm	Available only in Windows with bundled printer driver and for continuous media.
<b>11</b>	SPEED	2 ~ 6 IPS	5 IPS	Higher cover rate may cause the speed automatic reduction for better quality.
<b>12</b>	COUNTING	DOWN UP	DOWN	
<b>13</b>	MEDIASENSER TYPE	SEE-THROUGH REFLECTIVE	SEE- THROUGH	To select for different media types. After changing sensor setting, make sure to calibrate before printing. (Restart printer after change setting)
<b>14</b>	BACK FEED	DISABLE ENABLE	ENABLE	Available only in PPLA and PPLB printer languages. Once "ENABLE" is selected, printer enters BACK DISTANCE setting.
<b>15</b>	BACK DISTANCE	10~40 mm	22 mm	Available only when BACK FEED is enabled.
<b>16</b>	BASE DARKNESS	-28~28	0	
<b>17</b>	DARKNESS	0~30	16	To select darkness.
<b>18</b>	BAUD RATE	2400/ 4800 / 9600		Should be as same as setting of host.

		9600 / 19200 / 38400 / 57600 / 115200		(Restart printer after change setting)
<b>19</b>	PARITY (RS232)	NONE ODD EVEN	NONE	Should be as same as setting of host. (Restart printer after change setting)
<b>20</b>	LENGTH (RS232)	8 DATA BITS 7 DATA BITS	8 DATA BITS	Should be as same as setting of host. (Restart printer after change setting)
<b>21</b>	CLEAR FLASH	NO YES	NO	When "YES" is selected, all the label forms, soft fonts, and graphics stored will be deleted. (Restart printer after change setting)
<b>22</b>	SETTING PRIORITY	COMMAND/ LCD PANEL	COMMAND	Choosing priority of LCD settings. It decides which setting method - by command or by LCD panel, is prior.
<b>23</b>	EMULATION	AUTO PPLA PPLB PPLZ	AUTO	(Restart printer after change setting)
<b>24</b>	BUZZER	DISABLE ENABLE	ENABLE	
<b>25</b>	STANDBY	DISABLE 1 MINUTE 2 MINUTES 5 MINUTES 10 MINUTES 20 MINUTES 30 MINUTES	DISABLE	

---

			LAST SAVED:
			NO.1~15, NO.17, NO.22, NO.24~25 and language will be loaded.
		LAST SAVED	FACTORY:
<b>26</b>	LOAD DEFAULTS	FACTORY	NO.1, NO6, NO9, NO11, NO14~15, NO17, NO.27~30 will be loaded.
		NETWORK	NETWORK:
			NO.27~30 will be loaded.
			(Restart printer after change setting)

## Ethernet settings and parameters

NO.	Item	Range	Factory Default	Remarks
27	DHCP	DISABLE ENABLE		<p>If printer has been connected to a router, IP address will be assigned automatically by DHCP server after power on.</p> <p>If printer is not connected to a router, with DHCP disabled, settings of IP ADDRESS, SUBNET MASK, and DEFAULT GATEWAY settings will be available on LCD.</p> <p>Every time when DISABLE is changed to be ENABLE, LCD will prompt "ETHERNET CARD UPDATE FINISH..."</p> <p>Then please reboot the printer.</p>
28	IP ADDRESS	<u>x</u> xx.xxx.xxx.xxx	xxx range:0~255	<p>When DHCP is disabled, default IP address is 192.168.1.100.</p> <p>If "_" sign appears, that means that <b>DHCP</b> setting is disabled. On the contrary, <b>DHCP</b> setting is enabled.</p> <p>1. <b><u>FEED/CONFIG</u></b> : change contents. (ex. from 000.000.000.000 to 255.255.255.255)</p> <p>2. <b><u>PAUSE/CALIBR</u></b> : shift "_" sign position. (ex. from <u>255.255.255.255</u> to 255.255.255.255)</p> <p>3. <b><u>CANCEL/RESET</u></b> : Select next function setting. ("_" sign must at the third digit of each parameter, for example, <u>xxx</u>).</p> <p>4. To change IP ADDRESS or SUBNET MASK, enter DEFAULT GATEWAY setting, press CANCEL button once; LCD will prompt "ETHERNET CARD UPDATE FINISH..."</p> <p>Then reboot the printer.</p> <p>To have more information on Ethernet settings, please refer to Ethernet User's Guide.</p>
29	SUBNET MASK	<u>x</u> xx.xxx.xxx.xxx		
30	DEFAULT GATEWAY	<u>x</u> xx.xxx.xxx.xxx		
31	MAC ADDRESS	Read only		



**WiFi module (Option)**

Item	Range	Remarks
WIFI SSID	Read only	WIFI module is an option for iX6 Pro Series. Connect printer to PC and use print tool to set WIFI module. To have more information, please refer to Print Tool user guide.
WIFI IP ADDRESS	Read only	
WIFI SUBNET MASK	Read only	
WIFI GATEWAY	Read only	
WIFI MAC ADDRESS	Read only	

## 3.2 Printing Media Calibration & Configuration

Before calibration, be sure media and ribbon (for thermal transfer printing) have been loaded correctly. The label sensor needs to locate properly to index labels' gaps/ notches/ holes. After the media is loaded, please perform media calibration to calibrate the label sensor in advance. For printer without LCD, please see indicators.

1. Turn off the printer
2. Press and hold the **PAUSE** button and turn on the power.
3. When "CALIBRATION ..." is displayed on the LCD, and both READY and MEDIA indicators blink, release the **PAUSE** button.
4. The printer feeds 1 or 2 blank labels.
5. When "READY" is displayed, the READY and MEDIA indicators stop blinking but remain illuminated.

## 3.3 Printing a Configuration Report

To perform a self-test and print a configuration report, helping to check printer's print quality and internal settings. Steps as below:







1. Turn off the printer.
2. Load media and ribbon.
3. Press and hold the **FEED** button while turning on the power.
4. When "SELF-TEST ..." is displayed on the LCD, release the **FEED** button.
5. The printer now prints out a configuration report. (as the sample in next page)

All characters will be printed in 2 columns: the right shows characters received from your system, and the left are the corresponding hexadecimal values of the characters. It allows users or engineers to verify and debug the program.

For printer without LCD, please see indicators.

**Sample of Configuration Report**

```

LABEL PRINTER WITH FIRMWARE
1  iX6-250-V01.01 20170307 PPLB
2  STANDARD RAM : 32M BYTES
3  AVAILABLE RAM : 3676K BYTES
4  FLASH TYPE : ON BOARD 16M BYTES
5  AVAILABLE FLASH : 8448K BYTES
6  NO. OF DL SOFT FONTS(FLASH) : 1
7  NO. OF DL SOFT FONTS(RAM) : 0
8  NO. OF DL SOFT FONTS(HOST) : 0
9  H. POSITION ADJUST.: 0000
10 SEE-THRU SENSOR
11 REF: 0221 SEE: 0098
12 RTC TIME: 6/13/16(12:20:49)
13 MAX LABEL HEIGHT: 100 INCHES
14 PRINT WIDTH: 812 DOTS
15 LAB LEN(TOP TO TOP): 79mm
16 SPEED: 6 IPS
17 DARKNESS: 8
18 THERMAL TRANSFER
19 PRINT LENGTH: 12M
20 CUT COUNT:34
21 RS232: 9600, 8, N, 1P, XON/XOFF
22 CODE PAGE : English (437)
23 MEDIA : NON-CONTINUOUS
24 CALIBRATION MODE: INTELLI PRINT
25 BACKFEED DISABLED
26 CUTTER ENABLED
27 PEELER DISABLED
28 CUTTER/PEELER OFFSET: 0 <+-0.01mm>
29 IP ADDRESS: 0.0.0.0
30 SUBNET MASK: 0.0.0.0
31 GATEWAY: 0.0.0.0
32 MAC ADDRESS: 00-00-00-00-00-00
33 DHCP: ENABLED
34 DHCP CLIENT ID: FFFFFFFFFFFFFFFF
                      FFFFFFFFFFFFFFFF
35 DHCP HOST NAME:
36 SNMP: ENABLED
37 SOCKET COMM.: ENABLED
38 SOCKET PORT: 9100
39 IPV6 MODE: MANUAL
40 IPV6 TYPE: NONE
41 IPV6 ADDRESS: 0000:0000:0000:0000:
                      0000:0000:0000:0000
42 LINK LOCAL : 0000:0000:0000:0000:
                      0000:0000:0000:0000
43 PRODUCT SN: 00000000001
44 USB SN: 000000000001
45 CG ENABLED
46 ot(0,0)<0.1dot,0.01mm>
47 rm(0,0)<1+ 0-,0.01mm>
48 sm(0,0)<1+ 0-,0.01mm>
49 rv(302,250,52)<0.01v><P>
50 sv(246,100,145)<0.01v><P>
54 bv(329,9,320)<0.01v><P>
52 rso(0)<0.01mm>
53 sso(0)<0.01mm>
54 This is internal font 1. 0123456789 ABCabcXyz
55 This is internal font 2. 0123456789 ABCabcXyz
56 This is internal font 3. 0123456789 ABCabcXyz
57 This is internal font 4. 0123456789 ABCXYZ
58 THIS IS INTERNAL FONT
59 
60 
61 
62 
63 
64 

```

**1. Version Information**

The firmware version and its build date.

**2. Standard RAM**

Total SDRAM size.

**3. Available RAM**

RAM is able to be used.

**4. Flash Type**

The flash memory type and size.

**5. Available Flash**

Flash is able to be used.

**6. No of DL soft fonts (FLASH)**

The number of fonts is downloaded in Flash.

**7. No of DL soft fonts (RAM)**

The number of fonts is downloaded in RAM.

**8. No of DL soft fonts (HOST)**

The number of fonts is downloaded in USB HOST.

**9. H. Position Adjust**

Move the print position horizontally.

**10. Sensor Type**

The media sensor type such as reflective sensor.

**11. Label-less Calibration Value**

Check if a label-less calibration has been performed on the printer. If not, the value is 0000.

**12. RTC Time**

The date and time of the real-time clock (RTC). The default format is month/day/year (hour:minute:second). If your printer has a built-in RTC, the RTC time shows here.

**13. Max Label Height**

The max label length you can print at a time. For 200 dpi models, it is 100 inches; for 300 dpi models, it is 50 inches.

**14. Print Width**

The print width in dots.

**15. Lab Len (Top to Top)**

For non-continuous media, it is the length between the tops of two labels.

**16. Speed**

The speed of printing. The unit is inch per second (ips).

**17. Darkness**

The current darkness.

**18. Print Method**

It is either thermal transfer (TT) or direct thermal (DT) printing. TT requires ribbons and DT doesn't.

**19. Print Length**

The total print length.

**20. Cut Count**

It counts the times the cutter cuts.

**21. RS232 Protocol**

It lists RS-232C settings in the following order: baud rate, data length, parity check, stop bit and flow control.

**22. Code page**

The character set table.

**23. Media**

The media type in use.

**24. Calibration mode**

There are intelli mode and smart mode.

Intelli mode: Just install labels, latch print module, press FEED button once, and then the printer will feed 1-2 labels to detect next gap / black mark before printing. The printer will feed 1-2 labels automatically before printing, if FEED button is not pressed.

Smart mode: Print from the first label immediately according to label length setting. Make sure to carefully align label bottom edge at the tear-off position before printing.

**25. Backfeed Enabled/Disabled**

Enable or disable backfeed during the printing process. When it is enabled, the printer moves the paper forward in a predefined length 1 second after printing, and pulls the paper back in a predefined length once the printing begins again. When it is disabled, the printer won't move the paper at all.

**26. Cutter Enabled/Disabled**

Enable or disable the cutter during the printing process.

**27. Dispenser Enabled/Disabled**

Enable or disable the dispenser during the printing process.

**28. Cutter/Dispenser Offset**

Move the cutting line or the peeling position forward or backward. The value in the angle brackets is the offset unit.

**29. IP Address**

The static IP address of the printer. The default value is "192.168.1.1".

**30. Subnet Mask**

The manually specified subnet mask of the printer. The default value is "255.255.255.0."

**31. Gateway**

The manually specified gateway of the printer. The default value is "0.0.0.0."

**32. MAC Address**

The unique address assigned to the printer that connects to the internet.

**33. DHCP**

When DHCP is enabled, it assigns an IP address to the printer automatically.

**34. DHCP Client ID**

It is an arbitrary value sent to the DHCP server to reserve an IP address for the printer.

**35. DHCP Host Name**

The name of a DHCP client.

**36. SNMP**

When it is enabled, the host gets or sets parameters registered as SNMP entities.

**37. Socket Communication**

When it is enabled, the host communicates with the printer via the socket.

**38. Socket Port**

The socket number of the printer.

**39. IPv6 Mode**

It determines how you get the IPv6 address of your printer. There are three modes: MANUAL, DHCPv6 or AUTO.

**40. IPv6 Type**

It is the IPv6 address type of your printer. There are four types: NONE, NORMAL, EUI and ANY.

**41. IPv6 Address**

The static IPv6 address of your printer.

**42. Link Local**

The IPv6 address that used in a network segment. It is allocated automatically.

**43. Product SN**

The serial number of product.

**44. USB SN**

The Serial number of USB host.

**45. CG Enable**

Printer is able to use True Type font.

**46. TPH and Cutter Offset**

For developers to debug.

**47. Reflective Sensor Gap Calibration**

For developers to debug.

**48. See-Through Sensor Gap Calibration**

For developers to debug.

**49. Reflective Sensor Profile**

For developers to debug.

**50. See-Through Sensor Profile**

For developers to debug.

**51. Ribbon Sensor Profile**

For developers to debug.

**52. Reflective Sensor Offset**

For developers to debug.

**53. See-Through Sensor Offset**

For developers to debug.

**54-58. Font Image**

You can use them as the reference to check your label font.

**59-64. TPH Test Pattern**

You can use them to check broken pins on the printhead.

If your printer has a Wi-Fi module, your PPLB configuration label will contain the following entries:

```

WLAN FW VERSION:  1.00_____ 1
                DATE: 2015.05.26_____ 2
WLAN IP ADDRESS:  0.0.0.0_____ 3
WLAN SUBNET MASK: 0.0.0.0_____ 4
WLAN GATEWAY:     0.0.0.0_____ 5
WLAN MAC ADDRESS: 00-80-92-4F-77-35_____ 6
WLAN DHCP:        AUTO_____ 7
WLAN DHCP HOSTNAME: 00-80-92-4F-77-3_____ 8
                  : 5
WLAN SOCKET PORT: 9100_____ 9
WLAN SSID:        WIRELESS PRINTER_____ 10
WLAN MODE:        Infrastructure_____ 11
WLAN COUNTRY CODE: USA_____ 12
WLAN CHANNEL:     AUTO_____ 13
WLAN NETWORK AUTHENTICATION: Open_____ 14
WLAN WEP:         OFF_____ 15

```

### 1. FW Version

WLAN board firmware version.

### 2. Date

WLAN board firmware version date.

### 3. IP Address

The IP address of your printer. When DHCP is enabled, it shows the automatically assigned IP address; when DHCP is disabled, it shows the manually specified IP address.

### 4. Subnet mask

The netmask of your printer. When DHCP is enabled, it shows the automatically assigned netmask; when DHCP is disabled, it shows the manually specified netmask.

### 5. Gateway

The gateway of your printer. When DHCP is enabled, it shows the automatically assigned gateway; when DHCP is disabled, it shows the manually specified gateway.

### 6. Mac address

The unique address assigned to your printer that connects to the internet.

### 7. DHCP

When DHCP is enabled, it assigns an IP address to your printer automatically.

### 8. DHCP Hostname

The name of a DHCP client.

### 9. Socket Port

The socket number of the printer.



**10. SSID**

Short for service set identifier. It is the name of a wireless local area network.

**11. Mode**

There are ad-hoc and infrastructure mode. Refer to Print Tool Network type description from Technical manual.

**12. Country Code**

The country or region.

**13. Channel**

The Wi-Fi channel.

**14. Network Authentication**

There are six mode. Refer to Printer Tool Network authentication description from Technical manual.

**15. WEP**

Refer to Printer Tool Wep description from Technical manual.

PPLA

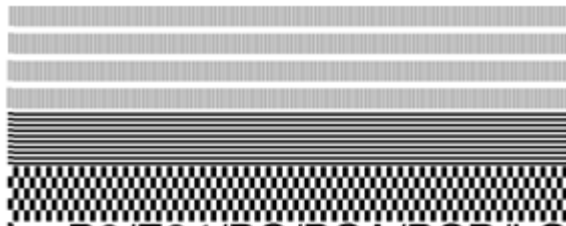

: R8/E94/PC/PCA/PCB/LG

Courier Fonts:

ASD Smooth font (18 points) - 12  
 ASD Smooth font (14 points) - 123456789  
 ASD Smooth font (12 points) - 123456789 ABCa  
 ASD Smooth font (11 points) - 123456789 ABCabcXyz  
 ASD Smooth font (8 points) - 123456789 ABCabcXyz  
 ASD Smooth font (6 points) - 123456789 ABCabcXyz  
 123456789

This is internal font 7. 0CR-A ABCabc  
**THIS IS INTERNAL FONT**  
 THIS IS INTERNAL FONT 5. 012345678  
 THIS IS INTERNAL FONT 4. 012345678  
 THIS IS INTERNAL FONT 3. 0123456789 ABCABC

This is internal font 2. 0123456789 ABCabcXyz  
 This is internal font 1. 0123456789 ABCabcXyz  
 This is internal font 0. 0123456789 ABCabcXyz  
 sso(0)<0.01mm>  
 rso(0)<0.01mm>  
 bu(329.9.320)<0.01u><P>  
 eu(246.100.145)<0.01u><P>  
 ru(302.250.52)<0.01u><P>  
 sm(0.0)<1+ 0-.0.01mm>  
 rm(0.0)<1+ 0-.0.01mm>  
 ol(0.0)<0.1dot.0.01mm>  
 CG ENABLED  
 USB SN: 000000000001  
 PRODUCT SN: 000000000001  
 0000-0000-0000-0000  
 LINK LOCAL : 0000-0000-0000-0000:  
 0000-0000-0000-0000  
 IPV6 ADDRESS: 0000-0000-0000-0000:  
 IPV6 TYPE: NONE  
 IPV6 MODE: MANUAL  
 SOCKET PORT: 9100  
 SOCKET COMM.: ENABLED  
 SNMP: ENABLED  
 DHCP HOST NAME:  
 FFFFFFFFFFFFFFFF  
 DHCP CLIENT ID: FFFFFFFFFFFFFFFF  
 DHCP: ENABLED  
 MAC ADDRESS: 00-00-00-00-00-00  
 GATEWAY: 0.0.0.0  
 SUBNET MASK: 0.0.0.0  
 IP ADDRESS: 0.0.0.0  
 CUTTER/PEELER OFFSET: 0 <+0.01mm>  
 PEELER DISABLED  
 CUTTER ENABLED  
 BACKFEED DISABLED  
 CALIBRATION MODE: INTELLI PRINT  
 MEDIA : NON-CONTINUOUS  
 STD CTRL CODES  
 CODE PAGE : PC-850  
 RS232 : 9600.8.N.IP.XON/XOFF(SOFTWARE)  
 CUT COUNT: 34  
 PRINT LENGTH: 12M  
 THERMAL TRANSFER  
 DARKNESS: 10  
 SPEED: 6 IPS  
 LAB LEN(TOP TO TOP): 79mm  
 PRINT WIDTH: 801 DOTS  
 MAX LABEL HEIGHT: 100 INCHES  
 RTC TIME: 6/13/16(12:22:44)  
 REF: 0221 SEE: 0090  
 SEE-THRU SENSOR  
 H. POSITION ADJUST.: 0000  
 NO. OF DL SOFT FONTS(HOST) : 0  
 NO. OF DL SOFT FONTS(RAM) : 0  
 NO. OF DL SOFT FONTS(FLASH) : 0  
 AVAILABLE FLASH : 8448K BYTES  
 FLASH TYPE : ON BOARD 16M BYTES  
 AVAILABLE RAM : 3676K BYTES  
 STANDARD RAM : 32M BYTES  
 iXG-250-U01.01 20170307 PPLA  
 LABEL PRINTER WITH FIRMWARE

## PPLZ

```

LABEL PRINTER WITH FIRMWARE
iX6-250-V01.01 20170307 PPLZ
STANDARD RAM : 32M BYTES
AVAILABLE RAM : 3676K BYTES
FLASH TYPE : ON BOARD 16M BYTES
AVAILABLE FLASH : 8448K BYTES
NO. OF DL SOFT FONTS(FLASH) : 0
NO. OF DL SOFT FONTS(RAM) : 0
NO. OF DL SOFT FONTS(HOST) : 0
H. POSITION ADJUST.: 0000
SEE-THRU SENSOR
REF: 0221 SEE: 0098
RTC TIME: 6/13/16(12:25:11)
MAX LABEL HEIGHT: 100 INCHES
PRINT WIDTH: 001 DOTS
LAB LEN(TOP TO TOP): 79mm
SPEED: 6 IPS
ABS. DARKNESS: 16
TRIM. DARKNESS: 0
THERMAL TRANSFER
PRINT LENGTH: 12M
CUT COUNT:34
RS232: 9600, 8, N, 1P, XON/XOFF
CARET CONTROL CHAR : <^> 5EH
DELIMITER CONTROL CHAR : <, > 2CH
TILDE CONTROL CHAR : <~> 7EH
CODE PAGE : USA1
MEDIA : NON-CONTINUOUS
CALIBRATION MODE: INTELLI PRINT
REPRINT AFTER ERROR : ENABLED
BACKFEED DISABLED
CUTTER ENABLED
PEELER DISABLED
CUTTER/PEELER OFFSET: 0 <+-0.01mm>
IP ADDRESS: 0.0.0.0
SUBNET MASK: 0.0.0.0
GATEWAY: 0.0.0.0
MAC ADDRESS: 00-00-00-00-00-00
DHCP: ENABLED
DHCP CLIENT ID: FFFFFFFFFFFFFFFF
FFFFFFFFFFFFFFF
DHCP HOST NAME:
SNMP: ENABLED
SOCKET COMM.: ENABLED
SOCKET PORT: 9100
IPV6 MODE: MANUAL
IPV6 TYPE: NONE
IPV6 ADDRESS: 0000:0000:0000:0000:
0000:0000:0000:0000
LINK LOCAL : 0000:0000:0000:0000:
0000:0000:0000:0000
PRODUCT SN: 0000000001
USB SN: 000000000001
CG ENABLED
ot(0,0)<0.1dot,0.01mm>
rm(0,0)<1+ 0-,0.01mm>
sm(0,0)<1+ 0-,0.01mm>
rv(302,250,52)<0.01u><P>
sv(246,100,145)<0.01u><P>
bv(329,9,320)<0.01u><P>
rso(0)<0.01mm>
sso(0)<0.01mm>
THIS IS FONT A. 0123ABCabc
THIS IS FONT B. 0123ABCabc
THIS IS FONT C. 0123ABCabc
THIS IS FONT D. 0123ABCabc
THIS IS FONT E. 0123ABCabc
THIS IS FONT F. 0123ABCabc
THIS IS FONT G.
THIS IS FONT H. 0123ABC
This Is Font CG Triumv Bd Condensed.

```

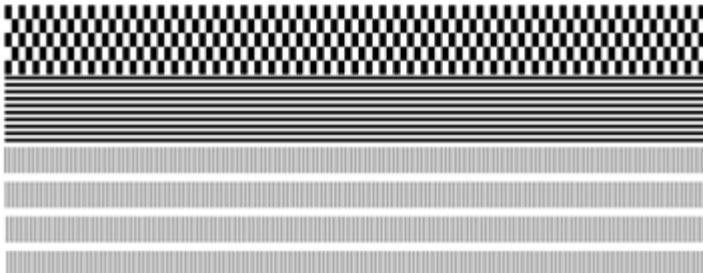

## 3.4 Resetting to Factory Default Settings

Be cautioned that this will reset all printer settings back to defaults; if possible, print the configuration label in advance before reset. All settings stored in FLASH memory are retained even after turning off the printer. Printer mode without LCD can see indicators.

To reset the printer to factory default settings:

1. Turn off the printer.
2. Press and hold the **CANCEL** button and turn on the printer.
3. When "RESET ..." is displayed on the LCD and the READY indicator blinks, release the **CANCEL** button.
4. When "READY" is displayed on the LCD, the READY indicator stops blinking but remains illuminated.
5. The following information is now back to defaults:
  - Label parameters
  - Heat (Darkness)
  - Speed
  - Others for specific emulation

For more detail information, refer to CH 3.1.1 NO.26 [Load default](#)

**Note:**

Print length meter which indicates label length already printed cannot be reset.

## 3.5 Media sensing

Printer offer two types of media sensor: transmissive and reflective. They are used for detecting specific media types. Both sensor types are installed together as a movable module.

### 3.5.1 Transmissive sensor

The transmissive sensor is used for detecting gaps across the entire width of the label.

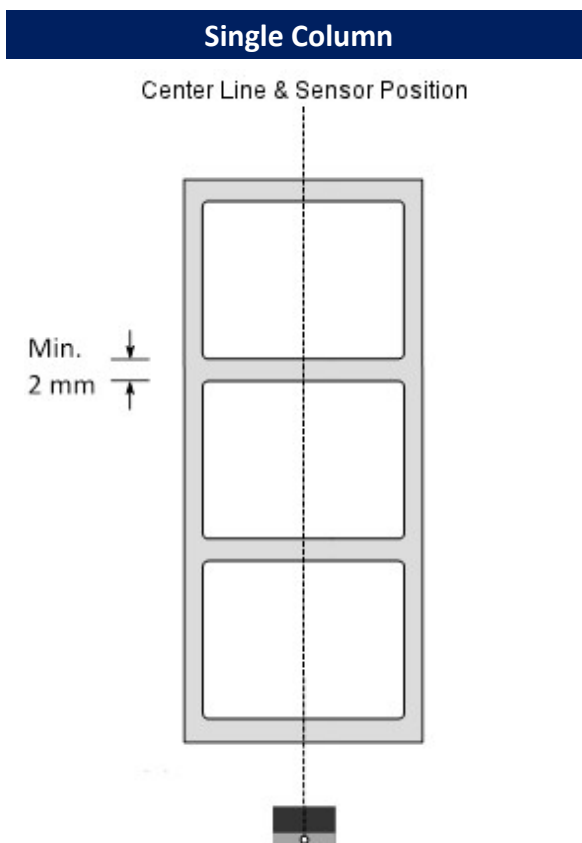

### 3.5.2 Reflective sensor

The reflective sensor detects gaps, notches and black marks.

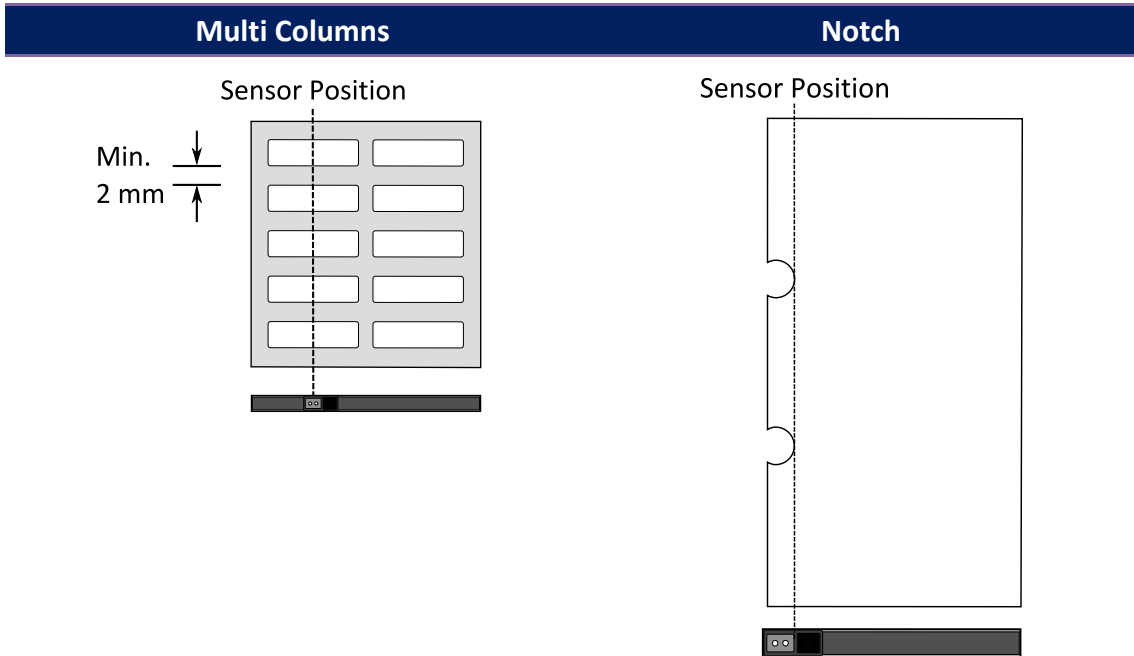

#### Black Mark

Flip the media so the black-mark side is facing down to align with the sensor.

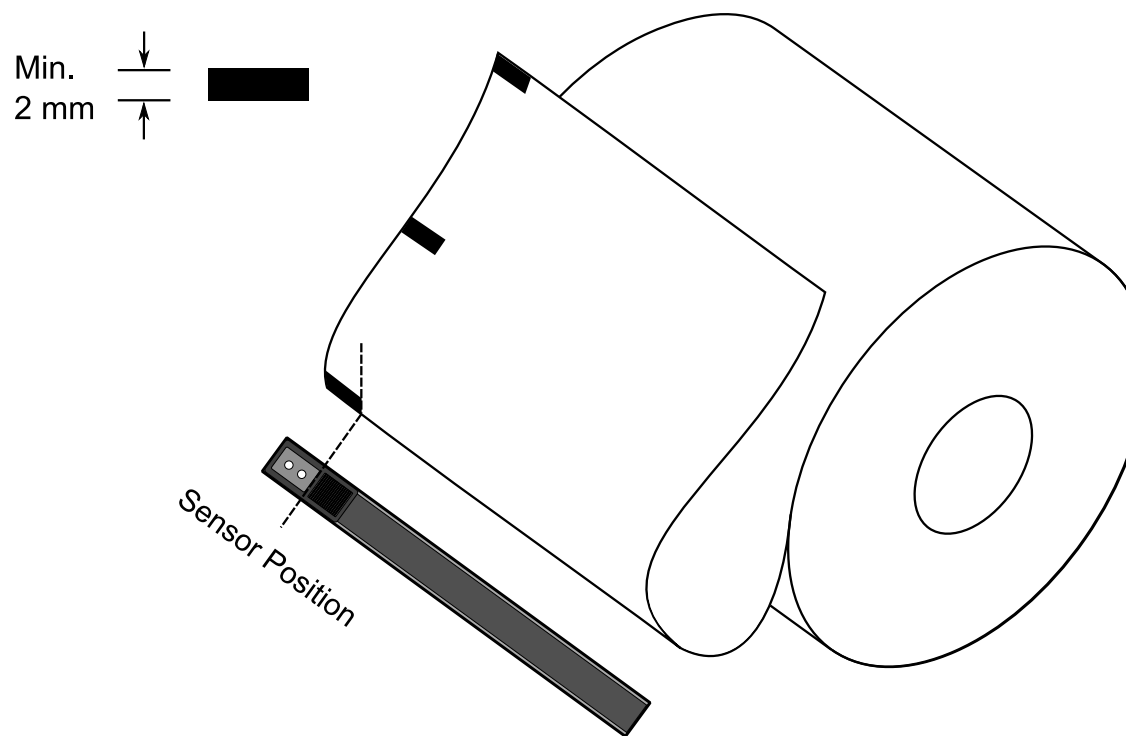

### 3.5.3 Adjust Position of Label Sensor

Function of the label sensor is to detect the gap, notch, or holes of labels, to help the printer for accurate print positions and label length. For labels with gaps, label sensor can be positioned wherever media locates. If labels with notches or holes are in use, pull in or out Paper Sensor Position Lever, to horizontally adjust position of label sensor

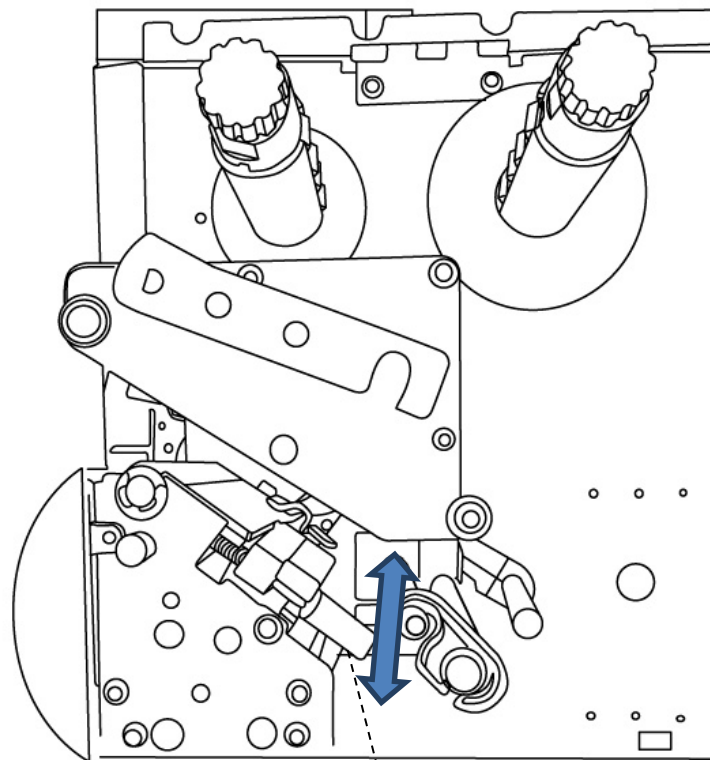

Paper Sensor Position Lever

- Make sure the Media sensor position mark locates right on notch or hole of labels. Check below.

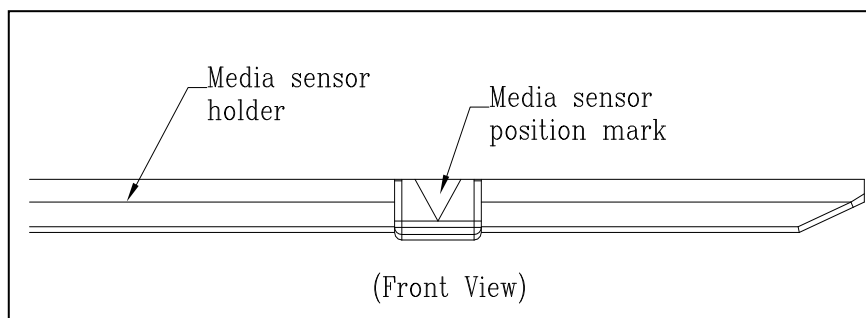

## 3.6 Communications

### 3.6.1 Interfaces and Requirements

This printer comes with two USB type A and a type B interface, a nine-pin Electronics Industries Association (EIA) RS-232 serial data interface, and GPIO interface (Option).

#### ■ USB Interface Requirements

The Universal Serial Bus (USB) interface is compatible with your existing PC hardware. The USB's "plug and play" design makes installation easy. Multiple printers can share a single USB port/hub. The different usage of type A and B as below.

USB type A	USB Flash drive, USB keyboard or USB Scanner.
USB type B	PC to set printer.

#### ■ Serial (RS-232) Port

The required cable must have a nine-pin "D" type male connector on one end, which is plugged into serial port located on the back of the printer. The other end of the cable connects to a serial port on the host computer. For technical and pin-out information, please refer to [RS-232C](#) in this manual.

#### ■ General-purpose input/output (GPIO)

Pins depend on usage and the signal is user selectable. The function is diversity. For general-purpose, I/O signals programmed as inputs can cause CPU interrupted. For more information, contact local dealer.



## ■ Ethernet Module Status Indicators

The indicators with two different colors help users understand status of Ethernet:

LED Status	Description	
<b>Both Off</b>	No Ethernet link detected.	
<b>Blinking</b>	The printer waits for printer ready. It will take about few seconds to be ready.	
<b>Orange (Yellow)</b>	Duplex/COL LED	On: Full duplex Off: Half duplex Blinking: Collision occurs
<b>Green</b>	Link/Activity LED	On: link up Off: link down Blinking: activity

## 3.7 Driver installation

The bundled printer driver can be applied to all applications under Windows XP/ Vista/ Windows 7/ Windows 8/ Windows 10, supporting 32-bit/ 64-bit operation systems. With this driver you can operate any popular Windows software applications including Argox Bartender UL label editing software or MS Word, etc., to print to this printer.

Drivers can be downloaded from Argox website (<https://www.argo.com/>).

### 3.7.1 Installing a Plug and Play printer driver (for USB only)



**Note:**

We strongly recommend that you use the Seagull Driver Wizard instead of the Microsoft Windows Add Printer Wizard when installing and updating your Drivers by Seagull.

(Even though the "Add Printer Wizard" is from Microsoft, it too easily performs a number of tasks incorrectly when updating existing drivers. It also badly handles the situation where a printer driver is already in use by a Windows application.)

1. Turn off the printer. Plug the power cable into the power socket on the wall, and then connect the other end of the cable to printer's power socket. Connect the USB cable to the USB port on the printer and on the PC.
2. Turn on the printer. If the printer supports Plug-and-Play, and you have successfully connected it using a USB cable, then the Windows Add Hardware Wizard will automatically detect the printer and display a dialog that allows you to install a driver. Click Cancel and do not install the driver using this wizard.
3. Run the driver from Argox website. On the prompt, Windows Printer Driver, select "I accept..." and click "Next".

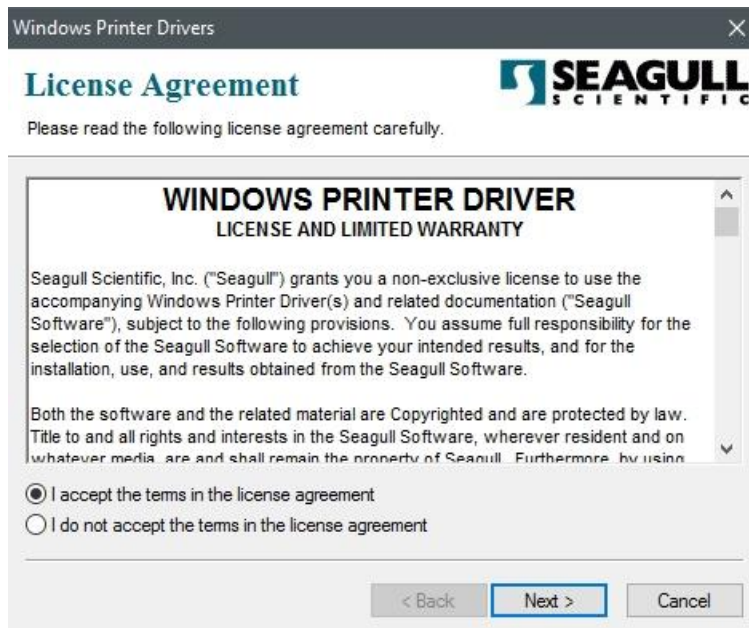

- Assign the directory to keep Seagull driver, (for example: C:\Seagull) and click "Next".

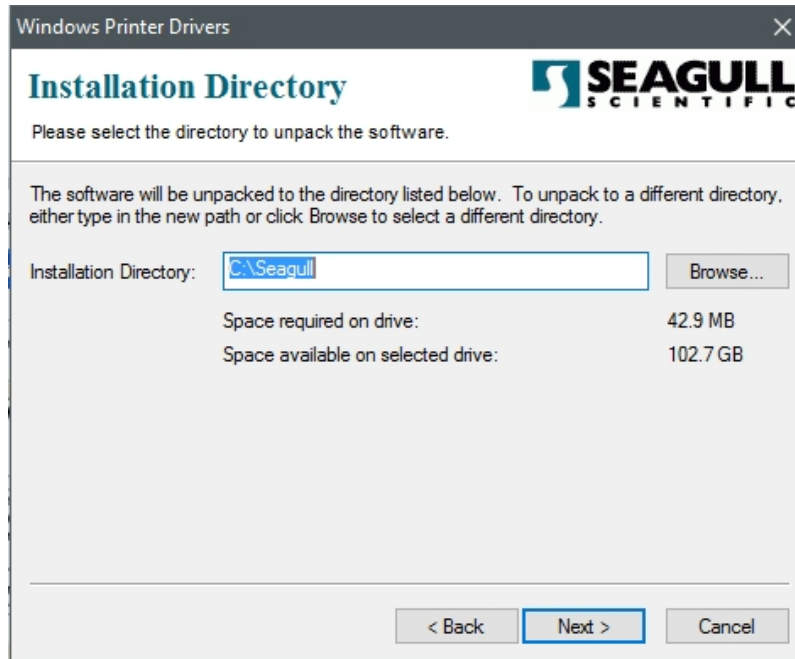

- Click "Finish".

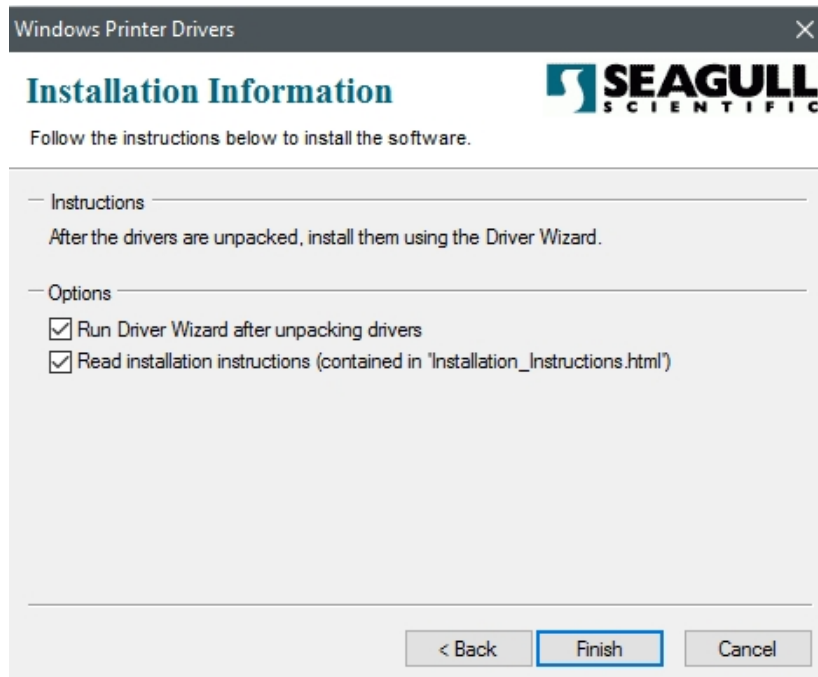

## 6. Select Install printer drivers and Click "Next"



## 7. On the Seagull Driver Wizard prompt, select the first radio button to "Install a driver for a Plug and Play printer" Then click "Next."

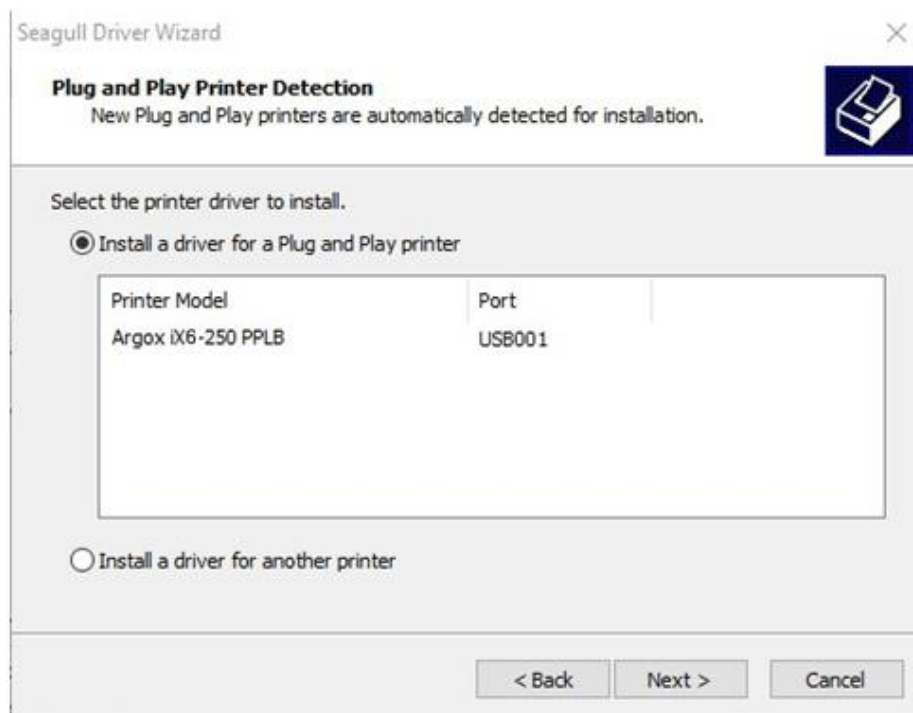

8. Enter Printer name (i.e. Argox iX6-250 PPLB) and select "do not share this printer", and click "Next"

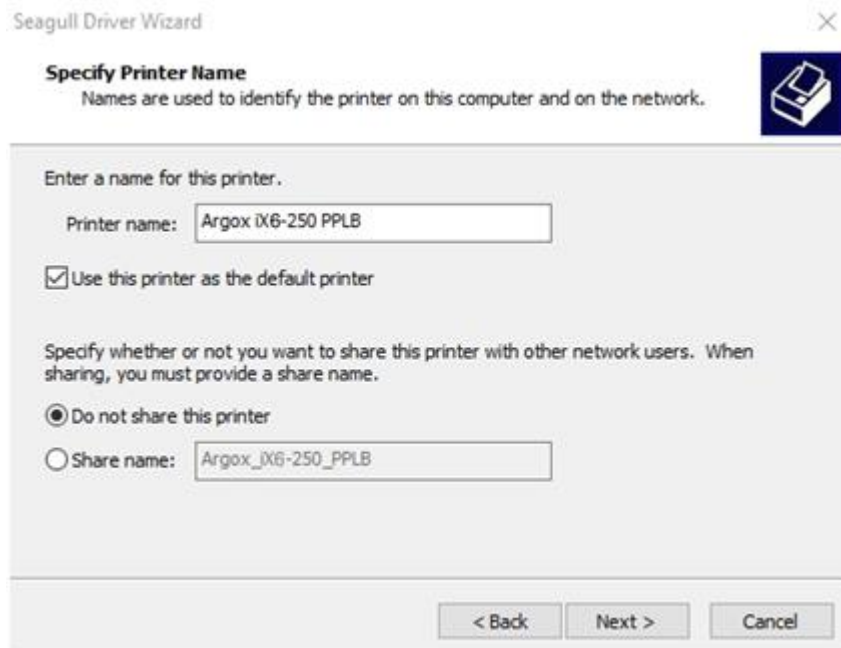

9. Check all the data on the showing screen, if it is correct, click "Finish".



10. After the related files have been copied to your system, click "Finish".

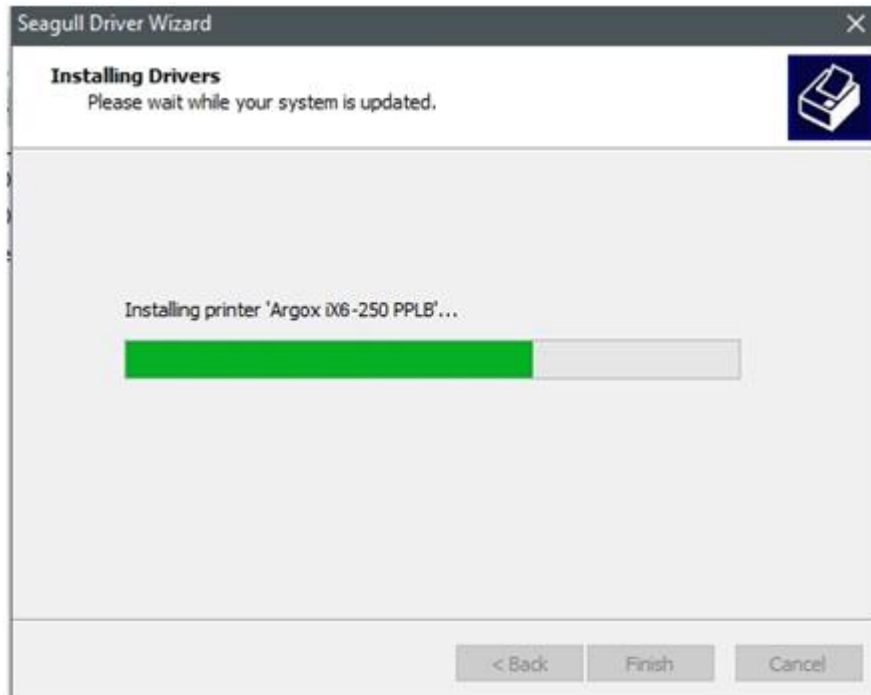

11. After driver installation is complete, click "Close". The driver should now be installed.

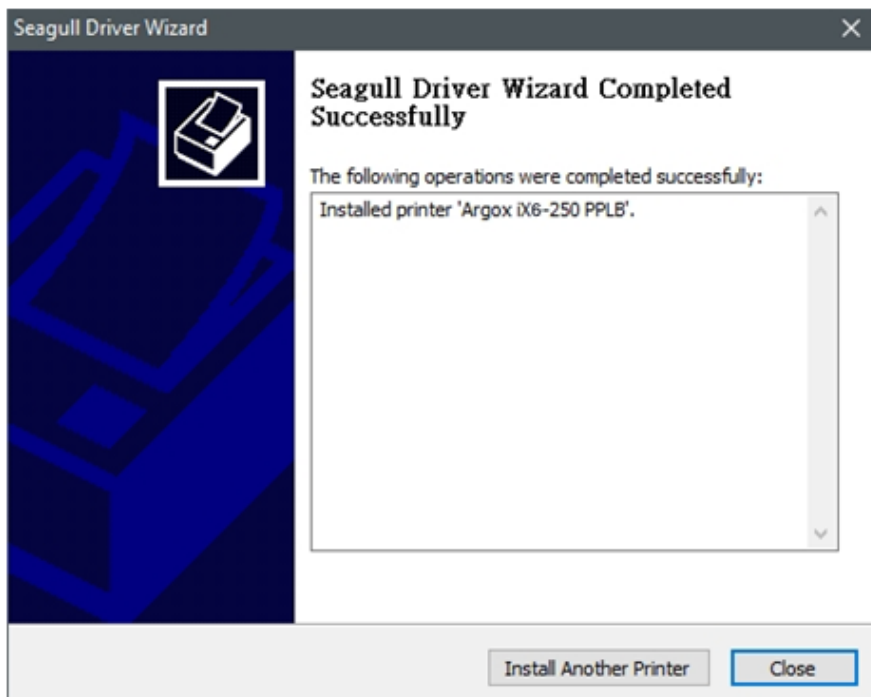

## 3.7.2 Installing a Printer Driver (for other interfaces except USB)

1. Turn off the printer. Plug the power cable into the wall power socket and connect the other end of the cable to the printer's power socket. Connect the Serial or Ethernet cable to the proper port on the printer and on your computer.
2. Run the driver from Argox website. On the prompt, Windows Printer Driver, select "I accept..." and click "Next".





- Assign the directory to keep Seagull driver, (for example: C:\Seagull) and click "Next".

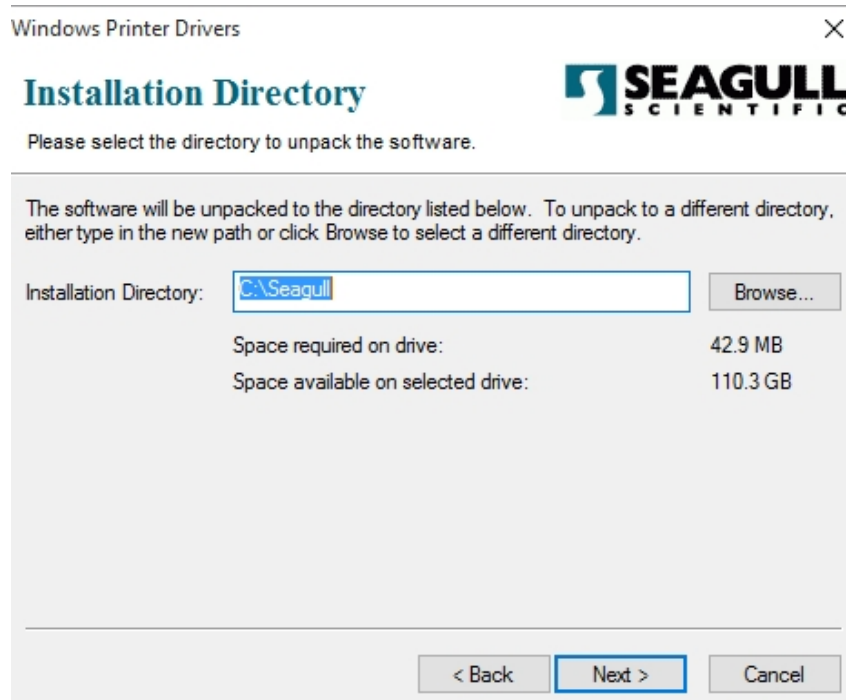

- Click "Finish".

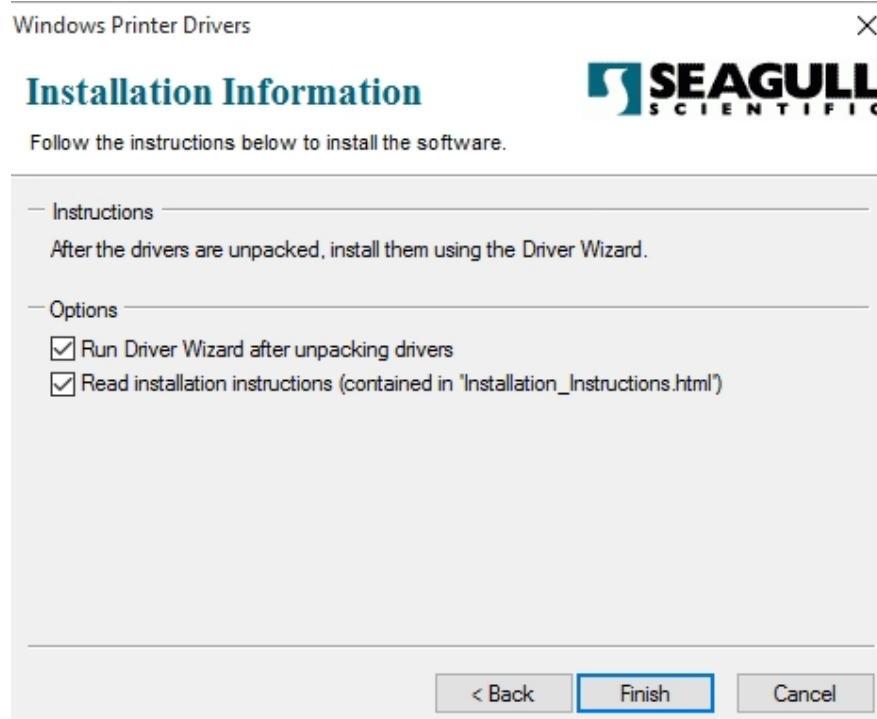

## 5. Select Install printer drivers and Click "Next"

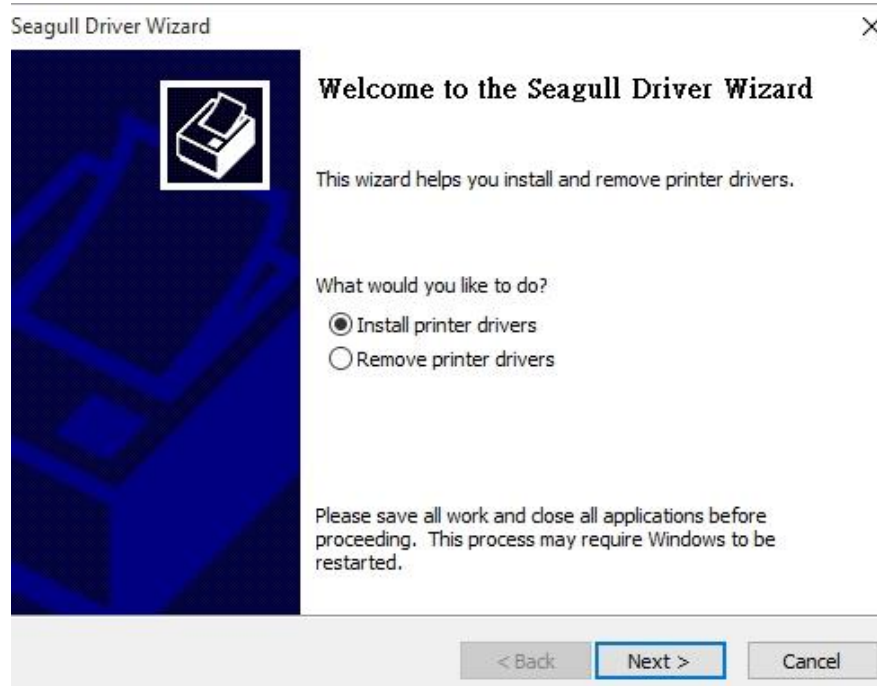

## 6. Make sure printer is connected to PC, select "Other" and click "Next":

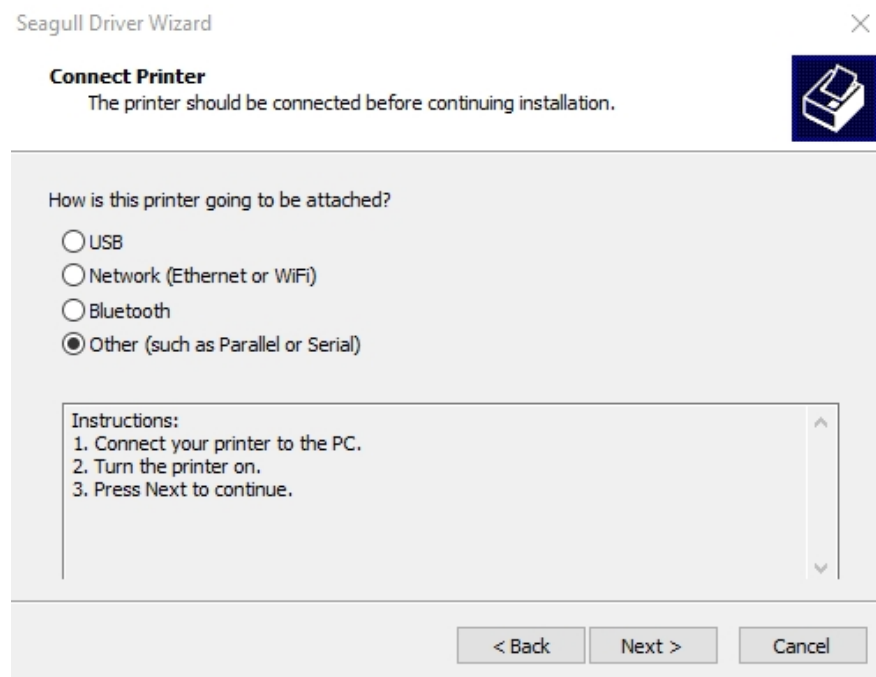

7. Select model & emulation - the following examples are based on model iX6-250

PPLB:

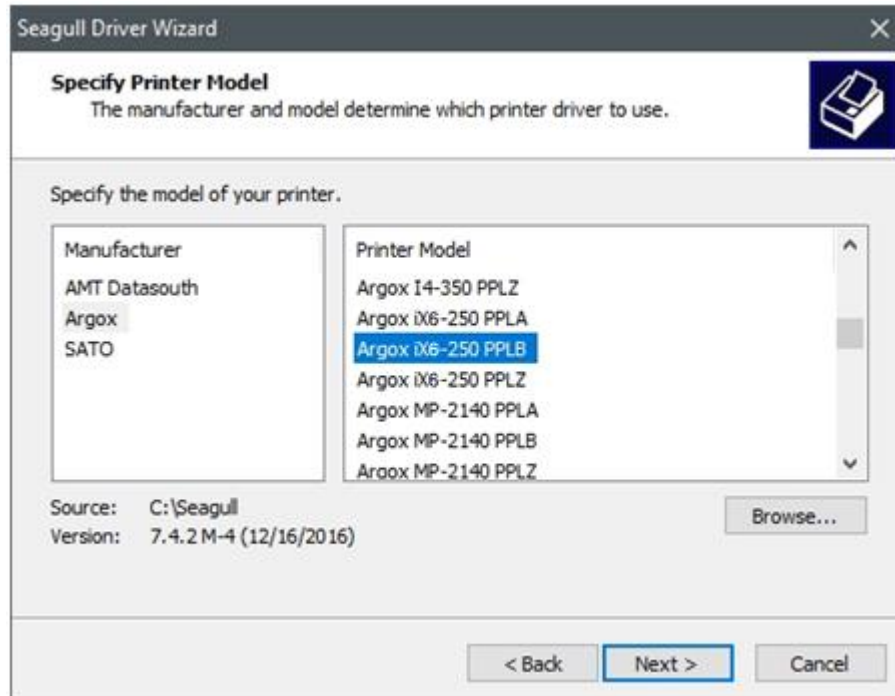

8. Select the port of the printer and click "Next".

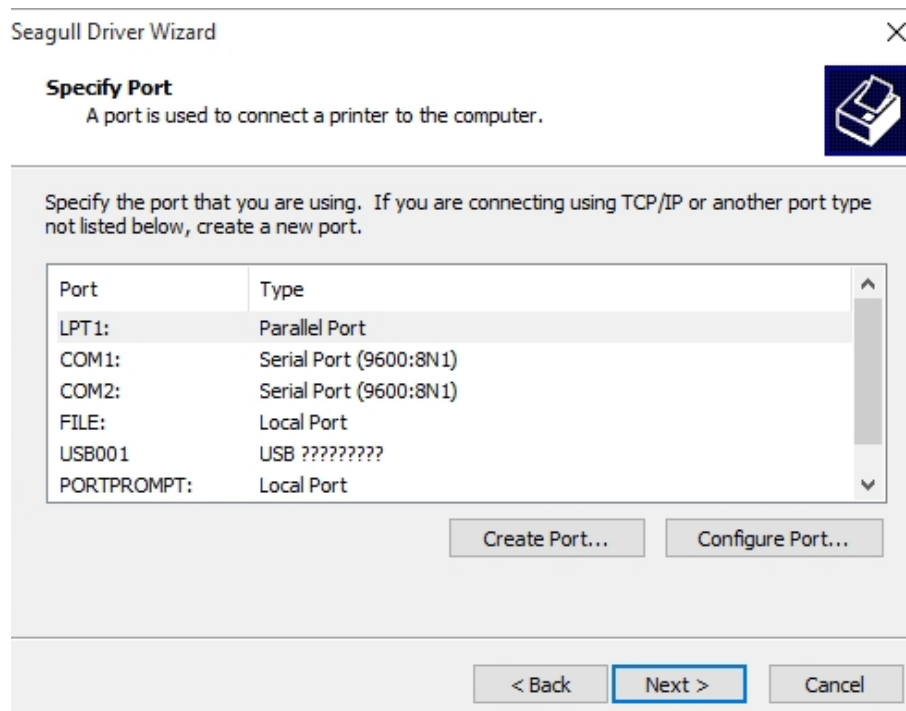

9. Enter Printer name (i.e. Argox iX6-250 PPLB) and select "do not share this printer", and click "Next".

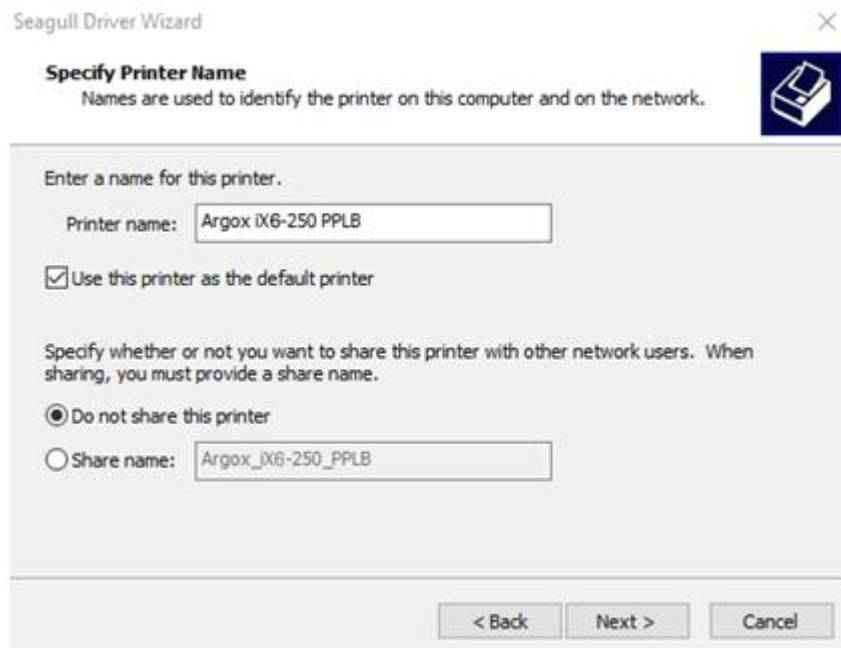

10. Check all the data on the showing screen, if it is correct, click "Finish".

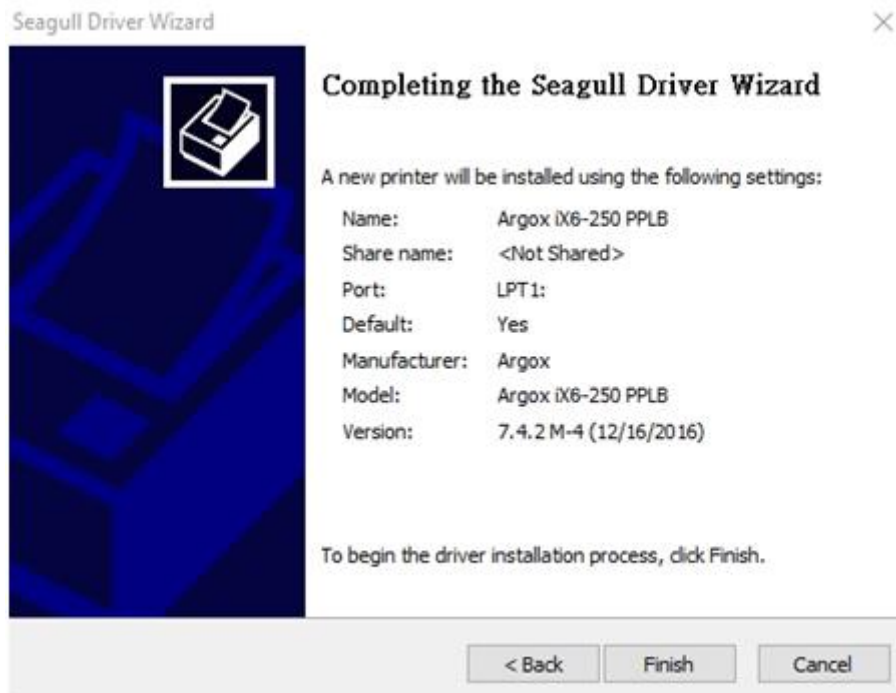

11. After the related files have been copied to your system, click "Finish".

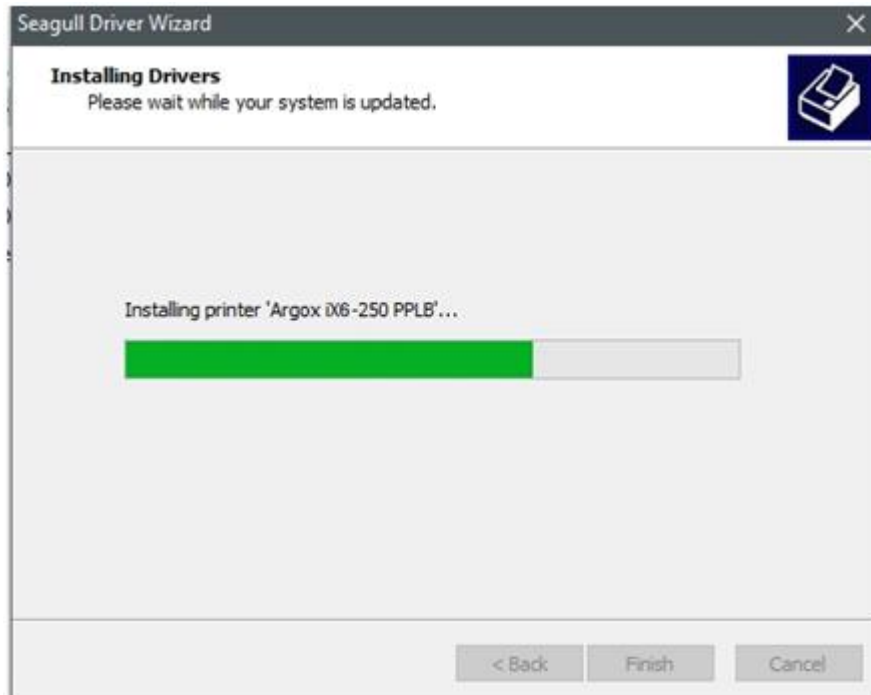

12. After driver installation is complete, click "Close". The driver should now be installed.

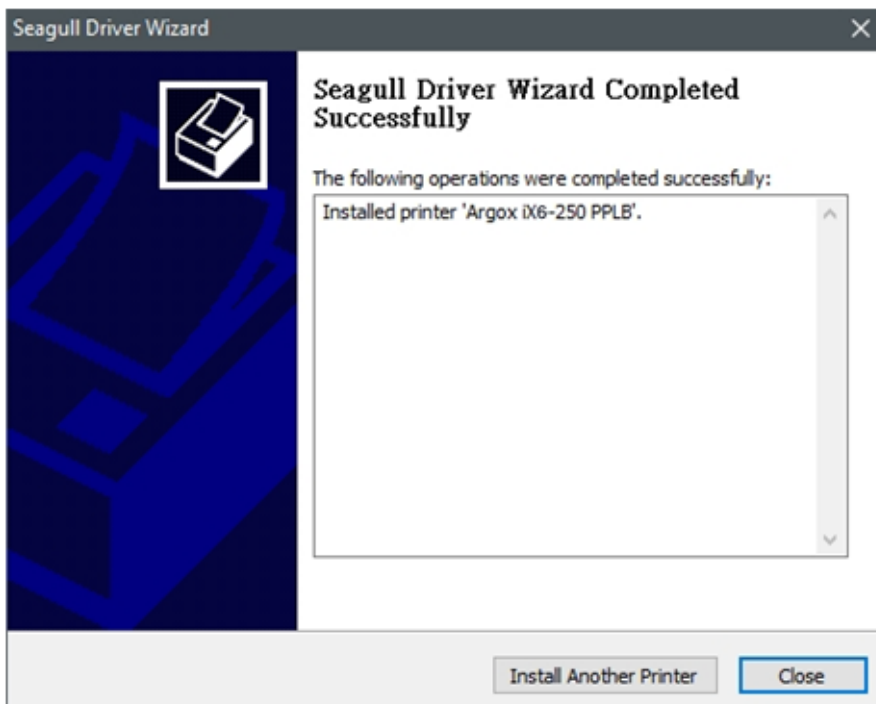

## 4 Maintenance

Vertical streaks in the printout usually indicate a dirty or faulty print head. (Refer to the following examples.) Clean the print head. If the problem persists, replace the print head.

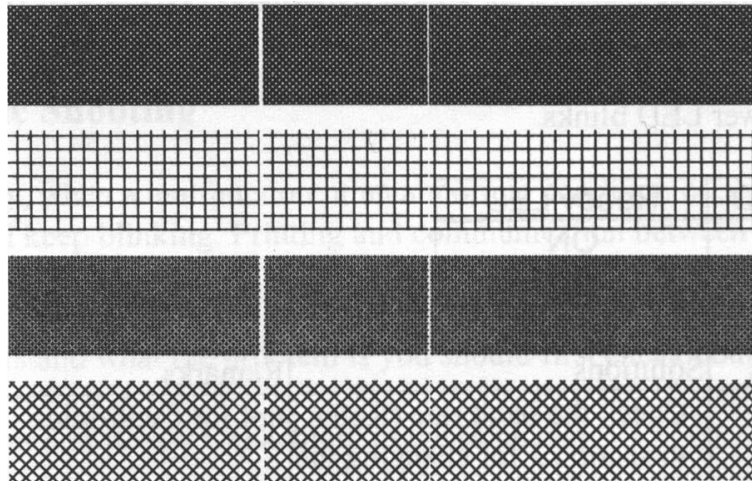

For unstable ribbon roll rotation, check the label path and make sure the head latch is securely closed.

Poor printout quality:

- The ribbon may not match the media in use.
- Adjust the Darkness (heat temperature).
- Slow down the print speed.
- Refer to the following and clean the related spare parts.

## 4.1 Cleaning

To maintain print quality and prolong the printer's life, you need to perform some routine maintenance. Daily maintenance should be done for high volume printing, and weekly for low volume printing.



**Warning** Always turn off the printer before cleaning.

### 4.1.1 Printhead

It is essential to keep printhead clean if you want the best print quality. We strongly recommend that you clean the printhead when you load a new media roll. If the printer is operated in critical environment, or the print quality declines, you need to clean the printhead more frequently.

Keep in mind these things before you clean:

- Keep the water away in case of corrosion on heating elements.
- If you just finish printing, wait until the printhead cools down.
- Do not touch the printhead with bare hands or hard objects.

Cleaning steps:

1. Moisten a soft cloth or a cotton swab with ethyl alcohol.
2. Gently wipe the printhead in one direction. That is, wipe it only from left to right or vice versa. Do not wipe back-and-forth, in case dust or dirt attaches to the printhead again.



**Note** Printhead warranty becomes void if printhead's serial number is removed, altered, defected, or made illegible, under every circumstance.

## 4.1.2 Platen Roller

The platen roller is also important for print quality. Dirty platen roller may damage the print head. Clean the platen roller right away if the adhesive, dirt or dust accumulates on it.

1. Moisten a soft cloth with absolute ethyl alcohol.
2. Gently wipe the platen roller to remove the dust and adhesive.



# 5 Troubleshooting

This chapter provides the information about printer problems and solutions.

## 5.1 Printer issues

### The printer won't turn on

- Did you attach the AC power cord?
- Check the power connection from the wall socket to the printer. Test the power cord and the socket with other electrical devices.
- Disconnect the printer from the wall socket, and connect it again.

### The printer turns itself off

- Turn on the printer again.
- If the printer keeps turning itself off, check the socket and make sure it has enough power for the printer.

### The printer does not feed the media out

- The media is not loaded correctly. See Section 2.3, "[Loading Media](#)" to reload the media.
- If there is a paper jam, clear it.

## 5.2 Media issues

### The media is out

- Load a new media roll.

### The paper is jammed

- Open the printer and clear the jammed paper.
- Make sure the paper is held properly by the **Media Guides**.

### The printing position is not correct

- Did you use the correct media type for printing?
- The media is not loaded correctly. See Section 2.3, "[Loading Media](#)" to reload the media.
- The media sensor needs to be calibrated. See Section 3.2, "[Printing Media Calibration & Configuration](#)" to calibrate the sensor.
- The media sensor is dirty. Clean the media sensor.

### Nothing is printed

- The media is not loaded correctly. See Section 2.3, "[Loading Media](#)" to reload the media.
- The print data might not be sent successfully. Make sure the interface is set correctly in the printer driver, and send the print data again.
- Make sure the media and ribbon are both matched.

### The print quality is poor

- The print head is dirty. Clean the print head.
- The platen roller is dirty. Clean the platen roller.
- Adjust the print darkness, or lower the print speed.
- The media is incompatible for the printer. Use appropriate media roll instead.

## 5.3 Ribbon issues

### The ribbon is out

- Load a new ribbon roll.

### The ribbon is broken

- Check the print darkness and adjust it if it is too high, and take the following steps to fix the broken ribbon:
  1. Unload the ribbon supply roll and take-up roll from the printer.
  2. Pull the ribbon from the supply roll so it overlaps the broken end of the take-up roll.
  3. Tape the overlapped parts together.
  4. Reload both rolls into the printer.

### The ribbon is “printed out” with the media

- The ribbon is not loaded correctly. See Section 2.4, “[Loading Ribbon](#)” to reload the ribbon.
- The print head temperature is too high. Reload the ribbon and print a configuration label to check the settings (See Section 3.2, “[Printing Media Calibration & Configuration](#)”). If the print darkness is very high, adjust it in printer preference, or reset your printer (see Section 3.3, “[Resetting to Factory Default Setting](#)”).

### The ribbon is wrinkled

1. Make sure the ribbon is loaded correctly.  
Rotate Thumb Wheel of Ribbon spindles to straighten the ribbon.

## 5.4 Other issues

### **There are broken lines in the printed label**

- The print head is dirty. Clean the print head.

### **The print head temperature is extremely high**

- The print head temperature is controlled by the printer. If it is extremely high, the printer will stop printing automatically, until the print head is cool down. After that, the printer will resume printing automatically, if there is any unfinished print job.

### **The print head is broken**

- Contact your local dealer for assistance.

# 6 Specifications

This chapter provides specifications for the printer.

## 6.1 Printer

Model	iX6-250 Pro
Print method	Direct Thermal & Thermal Transfer
Resolution	203 dpi (8 dots/mm)
Operation Mode	Standard: Continuous mode, Tear-off mode Optional: Cutter mode, Peeler mode
Sensor	Media Reflective sensor x 1 (movable) & Media Transmissive sensor x 1 (movable) / Head open switch / Ribbon end sensor
Operation interface	LED indicator x 3, Button x 3, LCD display
Print Speed	2-6 ips (51~152 mm/s)
Print Length	Max 100" (2540 mm) / Min 0.2" (5mm)
Print Width	6.6" (168 mm)
Communication Interface	Standard: Ethernet, dual USB hosts, USB device, RS-232 Option: Wi-Fi (IEEE 802.11 b/g/n), GPIO, Buzzer
Programming Language	PPLA+PPLB+PPLZ
Accessories	Rotary Cutter, Peeler
Onboard Memory	128MB DRAM (32MB available for user) 128MB Flash ROM (100MB available for user) USB storage up to 32 GB (FAT32 format only)
CPU Type	32 bit RISC microprocessor
Software---Label editing	Windows Driver (Windows XP/Vista/ Win 7/ Win 8/ Win 10), BarTender® from Seagull Scientific
Software--- Utility	Printer Tool
Agency Listing	CE, FCC, ICES, CB/LVD, BSMI



**Note** Print quality and speed is based on 15% print coverage.

## 6.2 Media & Ribbon

Properties	Description
<b>Media Size</b>	Max. width: 6.8" (173mm) / Min. width: 2" (50.8 mm) Thickness: 0.0025"~0.01" (0.0635mm~0.254mm) 8.26"(210mm) OD on a 3"(76mm) ID core. 7"(177.8mm) OD on a 1.5"(38mm) ID core. Min. length 1" (25.4mm) for cutter options. ※ <i>If the printer is equipped with an internal media rewinder, the maximum outer diameter of the media roll that can be used is 7 inches. This specification ensures the media can be properly fed and rewound within the printer's design.</i>
<b>Media Type</b>	Roll-feed, die-cut, continuous, fan-fold, tags, ticket or plain paper or label.
<b>Ribbon Size</b>	Width: 2"~6.78"(25.4mm~172mm) Length: max 450m Wax, 450m Semi-Resin. Max OD 3.2" (81.3 mm). Core size ID 1" (25.4 mm).
<b>Ribbon Type</b>	Wax, Wax/Resin, Resin (Ribbon wound ink-side out or ink-side in)

## 6.3 Electrical and operating environment

Properties	Description
<b>Power Supply</b>	Voltage: AC 100 V ~ 240 V ± 10 % (full range) Frequency: 50 Hz - 60 Hz ± 5 %
<b>Temperature</b>	Operating: 40°F~104°F (4°C~40°C) Storage: -4°F~122°F (-20°C~50°C)
<b>Humidity</b>	Operating: 25 %RH ~ 85 %RH (non-condensing) Storage: 10 %RH ~ 90 %RH (non-condensing)

## 6.4 Physical dimension

Dimension	Size and Weight
Size	W 318mm x H 262mm x D 470 mm
Weight	14kgs (31lbs), Net Weight 18kgs (40lbs), Gross Weight



**Note** The specifications may be changed at any time without prior notice. For more information about the new specifications, visit Argox website or contact your dealer.

## 6.5 Fonts, Barcodes, and Graphics Specification

The specifications of fonts, bar codes and graphics depends on the printer emulation. The emulations PPLA, PPLB, and PPLZ are printer programming languages, through which the host can communicate with your printer.

### Printer Programming Language PPLA

Programming Language	PPLA
Internal fonts	9 fonts with different point size 6 fonts with ASD smooth font. Courier font with different symbol sets.
Symbol sets (Code pages)	Courier font symbol set: Roman-8, ECMA-94, PC, PC-A, PC-B, Legal, and PC437 (Greek), Russian.
Soft fonts	Downloadable soft fonts by Print Tool
Font size	1x1 to 24x24 times
Character rotation	0, 90, 180, 270 degree, 4 direction rotation
Graphics	PCX, BMP, IMG, GDI and HEX format files
1D Barcodes	Code 39, UPC-A, UPC-E, Code 128 subset A/B/C, EAN-13, EAN-8, HBIC, Codabar, Plessey, UPC2, UPC5, Code 93, Postnet, UCC/EAN-128, UCC/EAN-128 K-MART, UCC/EAN-128 Random weight, Telepen, FIM, Interleaved 2 of 5 (Standard/with modulo 10 checksum/with human readable check digit/with modulo 10 checksum & shipping bearer bars), GS1

	Data bar (RSS)
2D Barcodes	MaxiCode, PDF417, Data Matrix (ECC 200 only), QR code, Composite Codes, Aztec

## Printer Programming Language PPLB

Programming Language	PPLB
Internal fonts	5 fonts with different point size
Symbol sets (Code pages)	8 bits code page : 437, 850, 852, 860, 863, 865, 857, 861, 862, 855, 866, 737, 851, 869, 1252, 1250, 1251, 1253, 1254, 1255 7 bits code page: USA, BRITISH, GERMAN, FRENCH, DANISH, ITALIAN, SPANISH, SWEDISH and SWISS
Soft fonts	Downloadable soft fonts by Print Tool
Font size	1x1 to 24x24 times
Character rotation	0, 90, 180, 270 degree, 4 direction rotation
Graphics	PCX , Binary Raster, BMP and GDI
1D Barcodes	Code 39, UPC-A, UPC-E, Matrix 2 of 5, UPC-Interleaved 2 of 5, Code 39 with check sum digit, Code 93, EAN-13, EAN-8 (Standard, 2/5 digit add-on), Codabar, Postnet, Code128 subset A/B/C, Code 128 UCC (shipping container code), Code 128 auto, UCC/EAN code 128 (GS1-128), Interleave 2 of 5, Interleaved 2 of 5 with check sum, Interleaved 2 of 5 with human readable check digit, German Postcode, Matrix 2 of 5, UPC Interleaved 2 of 5, EAN-13 2/5 digit add-on, UPCA 2/5 digit add-on, UPCE 2/5 digit add-on, GS1 Data bar (RSS)
2D Barcodes	MaxiCode, PDF417, Data Matrix (ECC 200 only), QR code, Composite Codes, Aztec



## Printer Programming Language PPLZ

Programming Language	PPLZ
Internal fonts	8 (A~H) fonts with different point size. 8 AGFA fonts: 7 (P~V) fonts with fixed different point size (not scalable). 1 (O) font with scaling point size.
Symbol sets (Code pages)	USA1, USA2, UK, HOLLAND, DENMARK/NORWAY, SWEDEN/FINLAND, GERMAN, FRANCE1, FRANCE2, ITALY, SPAIN, MISC, JAPAN, IBM850, Multibyte Asian Encodings, UTF-8, UTF-16 Big-Endian, UTF-16 Little-Endian, Code page 1250, 1251, ,1252, 1253, 1254
Soft fonts	Downloadable soft fonts by Print Tool
Font size	1x1 to 10x10
Character rotation	0, 90, 180, 270 degree, 4 direction rotation
Graphics	GRF, Hex and GDI
1D Barcodes	Code39, UPC-A, UPC-E, Postnet, Code128 subset A/B/C, Interleave 2 of 5, Interleaved 2 of 5 with check sum, Interleaved 2 of 5 with human readable check digit, Code 93, Code 39 with check sum digit, MSI, EAN-8, Codabar, Code 11, EAN-13, Plessey, GS1 Data bar (RSS), Industrial 2 of 5, Standard 2 of 5, Logmars
2D Barcodes	MaxiCode, PDF417, Data Matrix (ECC 200 only), QR code, Composite Codes, Aztec

## 6.6 Wireless LAN (Option)

Properties		Wireless LAN I/F		
Hardware	Protocol	IEEE 802.11 b/g/n		
	Enabled Device	WIRELESS PRINTER		
	Operating Temperature	-20°C ~ +85°C		
	Destination	USA	Europe	
	Frequency (Center Channel)	2412 ~ 2462 MHz	2412 ~ 2472 MHz	
	Channel	1 ~ 11 ch	1 ~ 13 ch	
	Spacing	5 MHz		
	Transmission Speed/Modulation	IEEE 802.11b	Transmission Method	Conforming to IEEE 802.11b DSSS method
			Channel	Depending on the country
	Transmission Speed/Modulation	IEEE 802.11g	Data Transmission Speed/Modulation	11/5.5 Mbps: CCK 2 Mbps: DQPSK 1 Mbps: DBPSK
			Transmission Method	Conforming to IEEE 802.11g OFDM method DSSS method
			Channel	Depending on the country

Properties		Wireless LAN I/F
	Data Transmission Speed/Modulation	54/48 Mbps: 64 QAM 36/24 Mbps: 16 QAM 18/12 Mbps: QPSK 9/6 Mbps: BPSK
IEEE 802.11n	Transmission Method	Conforming to IEEE802.11n OFDM method
	Channel	(US)1-11ch (JP/DE)1-13ch
	Data Transmission Speed/Modulation	20MHz : 6.5M / 7.2M / 13M / 14.4M / 19.5M / 21.7M / 26M /28.9M / 39M / 43.3M / 52M / 57.8M / 58.5M / 65M / 72.2M(Auto-sensing)
Antenna	External antenna	

Properties		Wireless LAN I/F	
Aerial power	802.11b	Max +15 dBm	
	802.11g	Max +17 dBm	
	802.11n	Max +17 dBm	
<b>Software</b>	Connection mode	Infrastructure, Adhoc	
	Default IP Address	192.168.1.1	
	Default Subnet Mask	255.255.0.0	
	Default ESSID	WIRELESS PRINTER	
	Security	IEEE 802.11i	
	Cryptography	WEP 128 bit, TKIP (WPA), AES (WPA2)	
	Authorization	Open Key (for WEP), PSK	
	Protocol (*)	TCP/IP, Socket, DHCP	
	Wireless LAN Parameter Setting and Status Monitor	Parameter Setting: Command (PC Setting Tool)	

## 6.7 Interfaces

This section provides information about IO port specifications for the printer.

### 6.7.1 USB

There are two common USB connectors. Typically, type A is found on hosts and hubs; type B is found on devices. The figure below shows their pinouts.

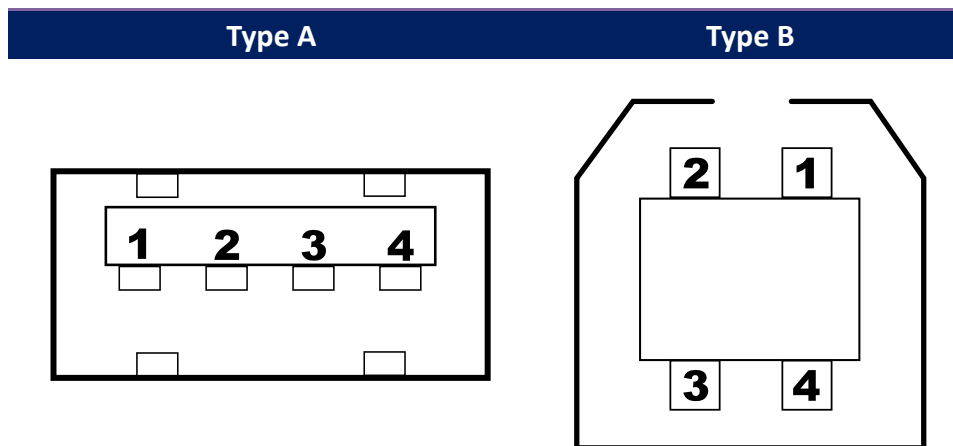

Pin	Signal	Description
1	VBUS	+5V
2	D-	Differential data signaling pair -
3	D+	Differential data signaling pair +
4	Ground	Ground

## 6.7.2 RS-232C

The RS-232C on the printer is DB9 female. It transmits data bit by bit in asynchronous start-stop mode. The figure below shows its pinout.

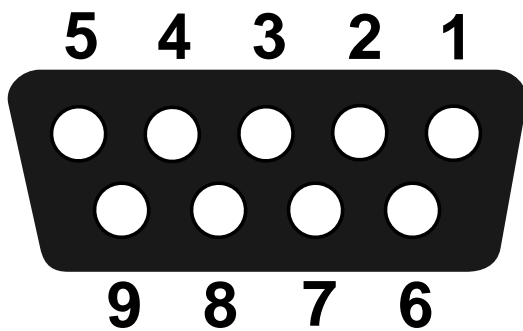

Pin	Signal	Description
1	NA	No Function
2	TxD	Transmit
3	RxD	Receive
4	NA	No Function
5	GND	Ground
6	NA	No Function
7	CTS	Clear to Send
8	RTS	Request to Send
9	NC	No Connection

Host (DB9)			Printer (DB9)		
Signal	Description	Pin	Pin	Description	Signal
CD	Carrier Detect	1	1	No Function	NC
RxD	Receive	2	2	Transmit	RxD
TxD	Transmit	3	3	Receive	TxD
DTR	Data Terminal Ready	4	4	No Function	NC
GND	Ground	5	5	Ground	GND
DSR	Data Set Ready	6	6	No Function	NC
RTS	Request to Send	7	7	Clear to Send	CTS
CTS	Clear to Send	8	8	Request to Send	RTS
CI		9	9	No Function	NC

### 6.7.3 GPIO

The input and output definition is below.

DB15 Pin No.	Direction (Power/In/Out)	Name	Port No.
1	P	GND	X
2	P	5V	X
3	Input	Start Print	CS4 bit0
4	Input	Feed	CS4 bit1
5	Input	Pause	CS4 bit2
6	Input	Reprint	CS4 bit3
7	P	24V	X
8	P	GND	X
9	NC	NC	X
10	Output	Serv_Req	PC18
11	Output	End_Print	PB21
12	Output	Meida Out	PC17
13	Output	Ribbon Out	PC18
14	Output	Data Ready	PC16
15	Output	OPT_Fault	PA25

Initialize:

- (1) During initialize process, please set all of output port to high for status clear, it means all of outputs are active low.
- (2) The active level maybe customize needed to modify.
- (3) The input normal state (idle) is high level, so the all of inputs are also active low.

## 6.7.4 Ethernet

The Ethernet uses RJ-45 cable, which is 8P8C (8-Position 8-Contact). The figure below shows its pinout.

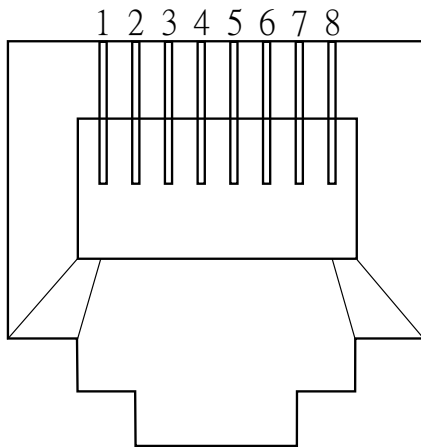

Pin	Signal
1	Transmit+
2	Transmit-
3	Receive+
4	Reserved
5	Reserved
6	Receive-
7	Reserved
8	Reserved



# 7 Dimensions

